

FILED

JUN 24 2019

IN THE UNITED STATES DISTRICT COURT CLERK U.S. DISTRICT COURT
FOR THE WESTERN DISTRICT OF PENNSYLVANIA WEST. DIST. OF PENNSYLVANIA

DOGGIE DENTAL INC., and
PETER DERTSAKYAN,

Plaintiffs,

v.

MAX_BUY, ADAMCHAHIR91, AIRAKA,
CHMYSM2018, CHINACOSTCO_COM, CUTE-
LITTLE-BEAR, DC_BIGSHOP1, DEALS4YOU9,
DEDICATEDSALESMAN, GOOD.DEALS411,
HANTETECH, MALIFA168,
PARTS_ONLINE_2015,
SHENGXINYIDE2019NEW, SHOPILINE,
SONGYUPENG1, 4DICE_INTERNATIONAL,
15OCEANESHOP, A281768443, ADORE-MART,
ALDOPETS, AWESOME*DEALS*TODAY,
BIGSQUIRRELISLAND, BORIS11184,
CASHOW002, CHAWTABSU0, CRAB-STORE,
DD2004720,
ELECTRONIC_ACCESSORY_SALES15,
ETRACKONLINE, GLOBAL-ONLINESHOP,
GOOD_GO1, HANGUANG2018,
HAPPY2SHOPPING2014, HAPPY-SHOP09,
HOMCA2018, HOME-STORE01,
ILOVEHOME2018, JAMAN38, JOSTEGEN0,
LAGACREYE, LETSBOOMBOOM, LUDAS_MB,
MAI202, MAKDEEP_0, MIGGIE77392012,
NUNUNY3090, NUTRASIL, OXWELLE, OZ-
SWEETDEALS, PARADISESTORE12,
PARMESAN_CLICHE, PARSAYT0, PHA_6296,
PLUSSALE2017, PORAMATSE, PRICENTER-
KSDY, QICH97, RALLIART401,
RCHCOMMERCE1, REBEL1964, REDFLOWER88,
RICJI-45, ROBERTTAYLOR1589, SAVVY-
VARIETY-SHOP, SELLINGDAILY90,
SHOPMALLCLUB14, SLAYWAY, SUNFURAX1,
TABLETASSEMBLYSALES1, THPH_5710,
TIMETREE88, TOWARDFOR,
TRUTHEDGE.TECH, ULEADER666,
US2014.RUNZH,

Civil Action No. 19-746

FILED UNDER SEAL

USA.BEST.BUYING.EXPERIENCE, USA_EZRA,
VEJUSSHOP17, WAREHOUSEDEALS365,
WEWELL888, YAIR_UZA, YAMBAYSTORE,
YVSG7734, ALLCOMMERCE27, BRUCESHARK-
003, CHUANHU-STORE, DAOS_34, ELSHM_23,
EXCELSPELLERUSA, GOHASTINGS,
JAPANMARKETPLACE, LJSUPERIORCHEW,
LUCID-DREAMS, LXLSPETS, MAEXUS2018,
OOBEST_SHOP, PEGE-318, PENINSULAHOME,
POWER-OPTION, PRESST_55, RAMAH76M9,
RAYSAL_64, RM_BEST_4U, SAVEYOURBUY,
SEDRA-MB, SHIMI_DI, SIMSHOP2018,
SMARTSHOPPER2018, SOONHUA2010,
THEBUSYBUNNY, UNIQUELY_DG, VESTUT-56,
and VIOLETROSECH,

Defendants.

COMPLAINT FOR DAMAGES AND INJUNCTIVE RELIEF

Doggie Dental, Inc. (“Doggie Dental”), a California corporation, and Peter Dertsakyan (“Dertsakyan”), an individual (collectively, Doggie Dental and Dertsakyan are hereinafter referred to as “Plaintiffs”), hereby sue Defendants, the Individuals, Partnerships, and Unincorporated Associations identified in the Caption and which are set forth in **Schedule “A”** hereto (collectively “Defendants”). Defendants have offered for sale, sold, and distributed knock-off versions of Plaintiffs’ BRISTLY™ dog toothbrush which closely mimic the appearance of Plaintiffs’ genuine product within this district and throughout the United States by operating e-commerce stores established at least via the eBay.com Internet marketplace using their respective Store Names and Seller Names set forth on **Schedule “A”** hereto (collectively, the “Seller IDs”). As set forth below, Defendants have infringed upon Plaintiffs’ common law trade dress rights; Defendants have also used Plaintiffs’ copyrighted photographs and/or common law BRISTLY trademark while marketing their knock-off products in a willful attempt

to pass off their knock-off products as genuine BRISTLY™ products. In support of their claims, Plaintiffs allege as follows:

NATURE OF THE ACTION

1. Dertsakyan is the inventor of the BRISTLY™ dog toothbrush and the owner of intellectual property related thereto; Doggie Dental is the exclusive licensee of such intellectual property. In 2016 Dertsakyan developed the idea behind the BRISTLY™ dog toothbrush. June 2017 saw the launch of the BRISTLY™ dog toothbrush for beta testing. Over 50,000 dog owners experienced effortless daily tooth brushing of their dogs with BRISTLY™. In early 2018, development and testing of a new version of the BRISTLY™ dog toothbrush occurred. In June 2018 a crowdfunding campaign was launched on kickstarter.com. In less than two months, \$466,000 was raised with the assistance of nearly 11,000 backers and reached its funding goal in one day; the campaign was featured on the homepage of kickstarter.com as one of its successful campaigns. The crowdfunding campaign was continued on indiegogo.com where an additional \$534,000 was raised with the assistance of over 11,000 additional backers. The crowdfunding campaign for the BRISTLY™ dog toothbrush is the campaign with the highest number of backers and the highest amount raised of any pet campaigns. The new version of the BRISTLY™ dog toothbrush went on sale in October 2018.

2. Defendants have offered for sale, sold, and distributed knock-off versions of the BRISTLY™ dog toothbrush (the “Infringing Product”) which closely mimic the appearance of Plaintiffs’ product and infringe upon Plaintiffs’ common law trade dress rights. Defendants’ have also used Plaintiffs’ copyrighted photographs and/or common law BRISTLY trademark to market their knock-off products in a willful attempt to pass off their knock-off products as genuine BRISTLY™ products.

3. Defendants' sale, distribution, and advertising of the Infringing Product are highly likely to cause consumers to believe that Defendants are offering genuine BRISTLY™ dog toothbrushes when in fact they are not. To illustrate, below are several examples which vividly show that the Infringing Product itself and the manner in which it is marketed is designed to confuse and mislead consumers into believing that they are purchasing Plaintiffs' BRISTLY™ Product or that the Infringing Product is otherwise approved by or sourced from Plaintiffs:

Plaintiffs' Copyrighted Image

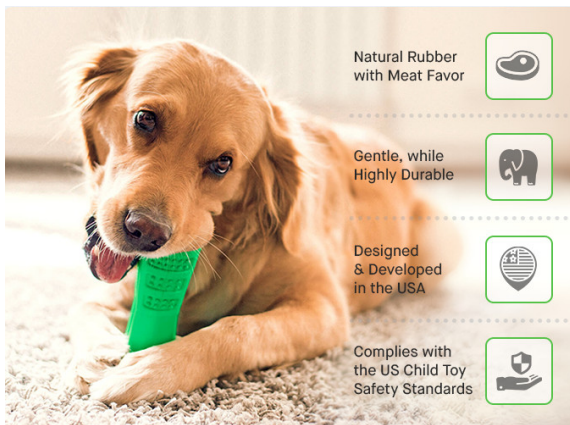


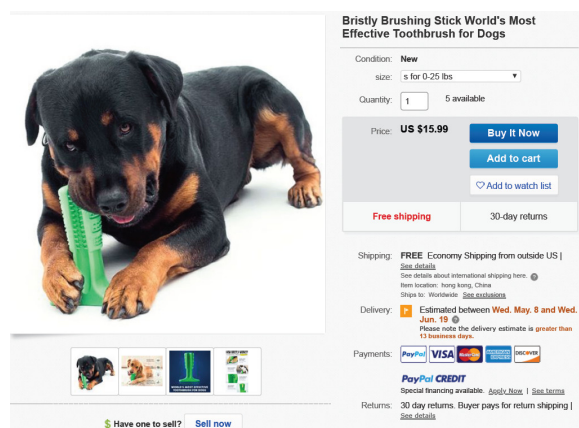
Image Used by Defendant chinacostco.com



Plaintiffs' Copyrighted Image



eBay Listing of Defendant dedicatedsalesman



Plaintiffs' Copyrighted Image

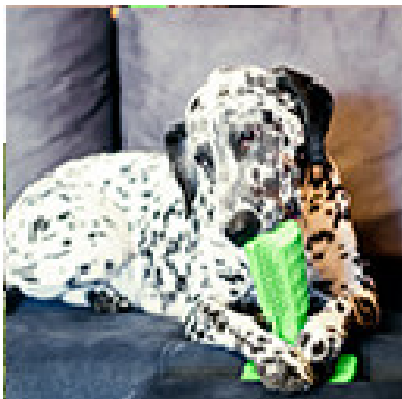


Image Used by Defendant tabletassembliesales1



4. Defendants' actions have resulted in actual confusion in the marketplace between Defendants' Infringing Product and genuine BRISTLY™ dog toothbrushes. Numerous purchasers of Defendants' Infringing Product have contacted Plaintiffs to complain about the performance of the Infringing Product believing same to be a genuine BRISTLY™ dog toothbrush. Examples of such complaints include "my dog destroyed your teeth cleaning thing in 10 seconds" and "I was so worried my dog may have eaten parts of it that I had to check him over at the vet." Such complaints and negative comments are not just made directly to Plaintiffs, but are also posted by members of the public on various websites and social media sites for all the world to see.

5. Defendants' Infringing Products are substantially inferior to the genuine product. Plaintiffs' genuine BRISTLY™ dog toothbrush is made of natural rubber. Defendants' Infringing Products are made with silicone or other materials. With poorly designed and manufactured products, Defendants' Infringing Products create serious public safety risks and threaten to destroy the reputation of high quality that Plaintiffs' BRISTLY™ products have earned. A graphic illustration of the significant danger that BRISTLY™ knock offs present to

animals was brought to the Plaintiffs' attention by a pet owner who believed that Doggie Dental sold a faulty and defective product when in actuality the pet owner purchased a knock off masquerading as an authentic BRISTLY™ dog toothbrush. The dog had chewed apart the fake product, swallowed a portion, and underwent corrective surgery to remove the piece. The pet owner provided the photographs below.

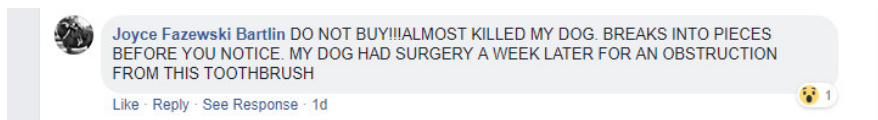
Bristly Knock Off Chewed by Dog



Injured Dog After Surgery



The pet owner wanted Doggie Dental to pay for the damages caused by the fake product. Additionally, the pet owner has previously publicized this post on Doggie Dental's publicly available Facebook page:



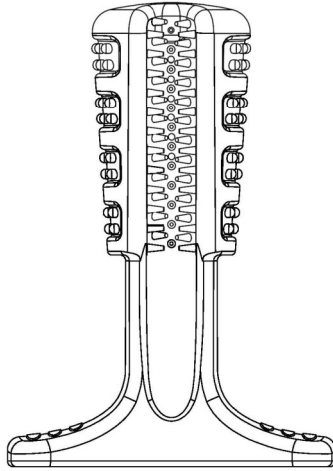
This pet owner's experience and posting highlight both the actual confusion between the knock offs and the genuine BRISTLY™ dog toothbrush and the immediate and irreparable injury being incurred by the Plaintiffs.

6. Plaintiffs have taken numerous steps to protect the BRISTLY™ dog toothbrush. Dertsakyan is the owner of U.S. copyright registration VA 2-122-455 directed to various photographs related to the BRISTLY™ dog toothbrush (the "Bristly Works"). A copy of

Dertsakyan's copyright registration certificate, together with copies of the deposit materials, is attached hereto as **Exhibit 1**. Dertsakyan is also the owner of unregistered copyrights related to the BRISTLY™ dog toothbrush.

7. In addition to his common law trademark rights in BRISTLY, Dertsakyan is also the owner of various pending trademark applications, including U.S. Application Serial No. 88/177,120 for BRISTLY on the Principal Register for goods which include "non-edible dental chews for pets;" examination of this application has concluded and the application was recently published for opposition by the U.S. Patent and Trademark Office. A copy of the Publication Confirmation dated March 26, 2019, is attached hereto as **Exhibit 2**. The opposition period closed on April 25, 2019, without any oppositions being filed and it is anticipated the trademark registration certificate will be issued issue in 2019.

8. Dertsakyan is also the owner of various design patent applications directed to the BRISTLY™ dog toothbrush, including an issued European Registered Community Design (005818606-0001), a pending U.S. design patent application, and a pending Chinese design patent application. A copy of Dertsakyan's Registered Community Design is attached hereto as **Exhibit 3**. All of the design patent applications have common figures, and one of the figures is set forth below:



9. Dertsakyan is also the owner of currently pending U.S. Patent Application No. 15/472,206 for “Pet chew toy for dental self-cleaning by domestic pets,” which was filed March 28, 2017. A copy of Plaintiffs’ U.S. Patent Application Publication No. 2018/0295811 is attached hereto as **Exhibit 4**. This utility patent application is currently undergoing examination at the U.S. Patent Office.

10. On information and belief, Defendants’ sale of Infringing Products gives rise to a plausible expectation that discovery will reveal that Defendants’ actions all arise from the same transaction, occurrence, or series of transactions. Specifically, on information and belief, Defendants are actively participating in a conspiracy to distribute and sell Infringing Products. For example, Defendants, on information and belief, are working together to manufacture, arrange the manufacture of and/or sell and otherwise distribute the Infringing Products. Moreover, the Infringing Products share similar characteristics including, for example, colors, shapes, and sizes.

11. Plaintiffs therefore bring this action for federal unfair competition in violation of Section 43(a) of the Trademark Act of 1946, as amended, copyright infringement of Plaintiffs’

federally registered copyrights in violation of the Copyright Act of 1976, common law unfair competition, and common law trademark infringement pursuant to 15 U.S.C. § 1125(a), 17 U.S.C. §§ 101 *et seq.*, and The All Writs Act, 28 U.S.C. § 1651(a).

JURISDICTION AND VENUE

12. This Court has subject matter jurisdiction over this action pursuant to 15 U.S.C. § 1121 and 28 U.S.C. §§ 1331, 1332, and 1338. This Court has supplemental jurisdiction pursuant to 28 U.S.C. § 1367 over Plaintiffs' state law claims because those claims are so related to the federal claims that they form part of the same case or controversy.

13. This Court may exercise personal jurisdiction over a non-resident of the State in which the Court sits to the extent authorized by the state's laws. Fed. R. Civ. P. 4(e). Pennsylvania authorizes personal jurisdiction over each Defendant pursuant to 42 Pa. Cons. Stat. § 5322 (a) which provides in pertinent part: "A tribunal of this Commonwealth may exercise personal jurisdiction over a person ... as to a cause of action or other matter arising from such person: (1) Transacting any business in this Commonwealth. Without excluding other acts which may constitute transacting business for the purpose of this paragraph: (ii) The doing of a single act in this Commonwealth for the purpose of thereby realizing pecuniary benefit ... (3) Causing harm or tortious injury by an act or omission in this Commonwealth. (4) Causing harm or tortious injury by an act or omission outside this Commonwealth ... (10) Committing any violation within the jurisdiction of the Commonwealth of any statute, home rule charter, local ordinance or resolution, or rule or regulation promulgated thereunder by any government unit or of any order of court or other government unit." In the alternative, Federal Rule of Civil Procedure 4(k) confers personal jurisdiction over the Defendants because, upon information and belief, Defendants regularly conduct, transact and/or solicit business in Pennsylvania and in this

judicial district, and/or derive substantial revenue from their business transactions in Pennsylvania and in this judicial district and/or otherwise avail themselves of the privileges and protections of the laws of the Commonwealth of Pennsylvania such that this Court's assertion of jurisdiction over Defendants does not offend traditional notions of fair play and due process, and/or Defendants' illegal counterfeiting and infringing actions caused injury to Plaintiffs in Pennsylvania and in this judicial district such that Defendants should reasonably expect such actions to have consequences in Pennsylvania and in this judicial district, for example:

a. Upon information and belief, at all times relevant hereto, Defendants were and/or are systematically directing and/or targeting their business activities at consumers in the United States, including Pennsylvania, through on-line platforms with Merchant Storefronts (as defined *infra*), via on-line marketplace websites, such as eBay.com, under the Seller IDs, as well as any and all as yet undiscovered accounts with Merchant Storefronts held by or associated with Defendants, their respective officers, employees, agents, servants and all persons in active concert or participation with any of them ("User Accounts"), through which consumers in the United States, including Pennsylvania, can view the one or more of Defendants' Merchant Storefronts that each Defendant operates, uses to communicate with Defendants regarding their listings for Infringing Products and to place orders for, receive invoices for and purchase Infringing Products for delivery in the U.S., including Pennsylvania, as a means for establishing regular business with the U.S., including Pennsylvania.

b. Upon information and belief, certain Defendants are sophisticated sellers, each operating one or more commercial businesses using their respective User Accounts through which Defendants, their respective officers, employees, agents, servants and all

persons in active concert of participation with any of them, operate storefronts to manufacture, import, export, advertise, market, promote, distribute, offer for sale and/or otherwise deal in products, including the Infringing Products, which are held by or associated with Defendants, their respective officers, employees, agents, servants and all persons in active concert or participation with any of them (“Merchant Storefront(s)”) in wholesale quantities at significantly below-market prices to consumers worldwide, including to those in the U.S., and specifically Pennsylvania.

c. Upon information and belief, Defendants’ Merchant Storefronts reflect multiple sales to consumers all over the world, including repeat sales to consumers in the U.S. and into this judicial district.

d. Upon information and belief, all Defendants accept payment in U.S. Dollars and offer shipping to the U.S., including to Pennsylvania.

e. Upon information and belief, at all times relevant, Defendants have transacted business with consumers located in the U.S., including Pennsylvania, for the sale and shipment Infringing Products.

f. Upon information and belief, Defendants are employing and benefiting from substantially similar, paid advertising and marketing and advertising strategies in order to make their Merchant Storefronts selling illegal goods appear more relevant and attractive to search result software across an array of search words, including but not limited to “BRISTLY”, and “WORLD’S MOST EFFECTIVE DOG TOOTHBRUSH”. By their actions, Defendants are causing concurrent and indivisible harm to Plaintiffs and the consuming public by (i) depriving Plaintiffs of their right to fairly compete for space

within the various on-line marketplace search results and reducing the visibility of the Plaintiffs' genuine BRISTLY™ dog toothbrush on various on-line marketplaces and/or diluting and driving down the retail market price for the genuine BRISTLY™ dog toothbrush (ii) causing an overall degradation of the value of the goodwill associated with Plaintiffs' marks and goods; and (iii) increasing Plaintiffs' overall cost to market its goods and educate consumers about its brand and products.

g. Upon information and belief, Defendants have cooperated, communicated their plans with one another, shared information, and coordinated their efforts, all in order to create an illegal marketplace operating in parallel to the legitimate marketplace of Plaintiffs' and the legally authorized resellers of Plaintiffs' genuine goods.

h. Upon information and belief, Defendants are concurrently targeting their counterfeiting and infringing activities toward consumers and causing harm in Allegheny County, Pennsylvania.

i. Upon information and belief, Defendants likely reside and/or operate in foreign jurisdictions with lax trademark and patent enforcement systems and are cooperating by creating an illegal stream of infringing and counterfeit goods.

j. Upon information and belief, Defendants are aware of Plaintiffs, their genuine BRISTLY™ dog toothbrush product, and are aware that their illegal infringing actions alleged herein are likely to cause injury to Plaintiffs in the United States, in Pennsylvania and in this judicial district specifically, as Plaintiffs conducts substantial business in Pennsylvania.

k. Plaintiffs are suffering irreparable and indivisible injury and suffered substantial damages as a result of Defendants' unauthorized and wrongful sale of counterfeit and infringing goods.

14. Venue is proper, *inter alia*, pursuant to 28 U.S.C. § 1391 and 28 U.S.C. § 1400(a) because, for example:

a. Upon information and belief, Defendants conduct, transact, and/or solicit business in this judicial district.

b. Upon information and belief, Defendants or their agent(s) may be found in this district because personal jurisdiction is proper in this district.

c. Upon information and belief, this is a judicial district in which a substantial part of the events or omissions giving rise to the infringement claims occurred, or a substantial part of the property that is the subject of the action is situated.

d. Defendants not resident in the United States may be sued in this judicial district because personal jurisdiction is proper in this district.

THE PLAINTIFFS

15. Plaintiff Doggie Dental, Inc., is a California corporation has a mailing address of 827 Hollywood Way #465, Burbank, California 91505. Doggie Dental is the exclusive licensee of the intellectual property relating to the BRISTLY™ dog toothbrush.

16. Plaintiff Peter Dertsakyan a/k/a Petros Dertsakyan, is an individual who resides in California and has a mailing address of 827 Hollywood Way #465, Burbank, California 91505. Dertsakyan is the inventor of the BRISTLY™ dog toothbrush and the owner of the intellectual property relating thereto.

17. Doggie Dental is, in part, engaged in the business of manufacturing and distributing throughout the world, including within this district, the BRISTLY™ dog toothbrush, through its website, bristly.com, its authorized seller on amazon.com, and various retail establishments, including Petsense. Defendants, through the sale and offer to sell Infringing Products are directly, and unfairly, competing with Plaintiffs' economic interest in the Commonwealth of Pennsylvania and causing Plaintiffs harm within this jurisdiction.

18. Like many other brand owners, Plaintiffs suffer ongoing daily and sustained violations of their rights at the hands of infringers, such as Defendants herein, who wrongfully reproduce Plaintiffs' products and use Plaintiffs' copyrighted images and common law trademarks for the twin purposes of (i) duping and confusing the consuming public and (ii) earning substantial profits. The natural and intended byproduct of Defendants' actions is the erosion and destruction of the goodwill associated with Plaintiffs' BRISTLY trademark and the destruction of the legitimate market sector in which Plaintiffs operate.

19. The recent explosion of counterfeiting and infringement over the Internet, including through online marketplace platforms, has created an environment that requires brand owners, such as Plaintiffs, to expend significant time and money across a wide spectrum of efforts in order to protect both consumers and Plaintiffs from the ill effects of confusion and the erosion of the goodwill associated with Plaintiffs' brand.

THE DEFENDANTS

20. The Defendants are individuals and/or business entities of unknown makeup, each of whom, upon information and belief, either reside or operate in foreign jurisdictions, or redistribute products from the same or similar sources in those locations. Defendants have the

capacity to be sued pursuant to Federal Rule of Civil Procedure 17(b). Defendants target their business activities toward consumers throughout the United States, including within this district, and conduct pervasive business through the operation of, at least, one fully interactive commercial Internet based e-commerce store via, at least, the Internet based online marketplace eBay.com under the Seller IDs.

21. Upon information and belief, the Defendants use aliases in conjunction with the operation of their businesses as set forth in **Schedule “A”** hereto.

16. Defendants are the past and present controlling forces behind the sale of products bearing and/or using infringements of Plaintiffs’ trade dress, common law trademark, and federally registered copyright as described herein using at least the Seller IDs.

17. Upon information and belief, Defendants directly engage in unfair competition with Plaintiffs and their authorized resellers by advertising, offering for sale and selling goods bearing and/or using infringements of Plaintiffs’ trade dress, common law trademark, and federally registered copyright to consumers within the United States and this district through several fully interactive, commercial Internet websites and Internet based e-commerce stores operating under, at least, the storefronts, the Seller IDs, and any additional domain names, websites and corresponding website URLs or seller identifications and store URL aliases not yet known to Plaintiffs. Defendants have purposefully directed some portion of their illegal activities towards consumers in the Commonwealth of Pennsylvania through the advertisement, offer to sell, sale, and/or shipment of Infringing Products into the Commonwealth.

18. Defendants have registered, established or purchased, and maintained the on-line marketplace website storefronts and Seller IDs. Upon information and belief, Defendants have

engaged in fraudulent conduct with respect to the registration of the storefronts and Seller IDs by providing false and/or misleading information to the Internet based e-commerce platforms where they offer for sale and/or sell, during the registration or maintenance process related to their respective Seller ID. Upon information and belief, Defendants have anonymously registered and maintained some of the Seller IDs for the sole purpose of engaging in illegal infringing activities.

19. Upon information and belief, Defendants will continue to register or acquire new seller identification aliases for the purpose of selling and offering for sale goods bearing and/or using confusingly similar imitations of Plaintiffs' trade dress and trademark and infringing Plaintiffs' federally registered copyright unless preliminarily and permanently enjoined.

20. Defendants' Internet-based businesses amount to nothing more than illegal operations established and operated in order to infringe the intellectual property rights of Plaintiffs.

21. Defendants' business names, i.e., the Seller IDs, associated payment accounts, and any other alias seller identification names used in connection with the sale of infringing goods bearing and/or using Plaintiffs' respective trade dress, trademark, and copyrighted images are essential components of Defendants' online activities and are the means by which Defendants further their infringement scheme and cause harm to Plaintiffs. Moreover, Defendants are using Plaintiffs' trademark to drive Internet consumer traffic to their e-commerce stores operating under the Seller IDs, thereby creating and increasing the value of the Seller IDs and decreasing the size and value of Plaintiffs' legitimate consumer marketplace at Plaintiffs' expense.

COMMON FACTUAL ALLEGATIONS

Plaintiffs and Their BRISTLY Dog Toothbrush

22. Plaintiffs developed and sell a unique and revolutionary product under the common law trademark BRISTLY (“Bristly Mark”) that safely and easily permits dogs to brush their own teeth removing plaque and tarter (“BRISTLY™ Product”). Plaintiffs identified the need for this product and created the market for this product. Below is an image of one of Plaintiffs’ BRISTLY™ Products, which retails for \$16.99:



The Bristly Mark is inherently distinctive, as recognized by the U.S. Patent and Trademark Office in stating the Bristly Mark “appears to be entitled to registration” on the Principal Register.

23. BRISTLY™ Products have a unique and distinctive trade dress, which is characterized by the ornamental features shown and described in Plaintiffs’ design patent applications and variations thereof (the “BRISTLY™ Trade Dress”). The arrangement and combination of these features are arbitrary, non-functional, and fanciful and constitute legally protectable trade dress. The BRISTLY™ Trade Dress has acquired secondary meaning identifying Plaintiffs as the source of products bearing it. This secondary meaning was acquired prior to use of the BRISTLY™ Trade Dress by Defendants.

24. Plaintiffs' Bristly Mark and Bristly Trade Dress have been used in interstate commerce to identify and distinguish Plaintiffs' goods.

25. Plaintiffs' Bristly Mark and Bristly Trade Dress have been used by Plaintiffs prior in time to Defendants' use of this mark and trade dress. The Bristly Mark and Bristly Trade Dress has never been assigned or licensed to any of the Defendants in this matter.

26. The Bristly Mark and Bristly Trade Dress is a symbol of Plaintiffs' quality, reputation, and goodwill and have never been abandoned.

Plaintiffs' Bristly Product has been featured in videos or articles by numerous media outlets, including MSN (<https://www.msn.com/en-sg/lifestyle/lifestylegeneral/a-new-chew-toy-will-help-your-dog-brush-its-own-teeth/ar-AAA8pvh>), Pet Lover Geek (<https://www.facebook.com/petlovergeek/videos/613996128985404>), Askmen (https://www.askmen.com/entertainment/guy_gear/best-new-kickstarters-for-june-28-2018.html), Interesting Engineering (<https://interestingengineering.com/this-chew-stick-for-dogs-helps-them-achieve-good-oral-health>), Awesome Stuff 365 (<https://awesomestuff365.com/bristly-toothbrush-for-dogs/>), star2.com (<https://www.star2.com/living/2018/07/28/toothbrushing-stick-dogs-clean-teeth/>), Dude (<http://www.dudeiwantthat.com/household/pets/bristly-toothbrush-for-dogs.asp>), Gaget flow (<https://thegadgetflow.com/blog/bristly-is-the-chew-toy-that-cleans-your-dogs-teeth/>) and (<https://thegadgetflow.com/portfolio/dog-tooth-brushing-stick/>), The Gadgeteer (<https://thegadgeteer.com/2018/07/20/micro-veggie-growing-tray-tiny-edc-pen-a-toothbrush-for-dogs-and-more-notable-crowdfunding-campaigns/>), Steemit (<https://steemit.com/steemhunt/@adarshagni/bristly-chew-stick-for-dogs>), New Atlas (<https://newatlas.com/bristly-dog-toothbrush/55401/>), TheThings.com

(<https://www.thethings.com/chew-toy-helps-dogs-brush-teeth>), slashpets
(<https://www.slashpets.com/bristly-toothbrush/>), Cool Business Ideas
(<https://www.coolbusinessideas.com/archives/toothbrush-for-your-doggy/>), Cool Hunting
(<https://coolhunting.com/design/bristly-dog-toothbrush/>), MNN
(<https://www.mnn.com/family/pets/stories/answer-dog-toothbrushing-struggle>), Gismo Review
(<https://www.gismoreview.com/bristly-the-toothbrush-for-dog/>), Product Watch
(<https://productwatch.co/hate-brushing-your-dogs-teeth-meet-bristly-and-forget-your-tribbles/>),
Mental Floss (<http://mentalfloss.com/article/551054/new-chew-toy-will-help-your-dog-brush-its-own-teeth>), and Trend Hunter (<https://www.trendhunter.com/trends/bristly>).

27. Plaintiffs have extensively used, advertised, and promoted the Bristly Mark and Bristly Trade Dress in the United States in association with pet products. As a result of Plaintiffs' efforts, members of the consuming public readily identify merchandise bearing or sold under the Bristly Mark and Bristly Trade Dress as being high quality goods sponsored and approved by Plaintiffs.

28. Genuine goods bearing the Bristly Mark and Bristly Trade Dress are widely legitimately advertised and promoted by Plaintiffs, their authorized distributors, and unrelated third parties via the Internet. Over the past several years, visibility on the Internet, particularly via Internet search engines such as Google, Yahoo!, and Bing has become increasingly important to Plaintiffs' overall marketing. Thus, Plaintiffs and their authorized distributors expend significant monetary resources on Internet marketing, including search engine optimization ("SEO") strategies. Those strategies allow Plaintiffs and their authorized retailers to fairly and legitimately educate consumers about the value associated with Plaintiffs' brand and the goods

sold thereunder. Similarly, Defendants' individual seller stores are indexed on search engines and compete directly with Plaintiffs for space in the search results.

Defendants' Wrongful and Infringing Conduct

29. Upon information and belief, Defendants are promoting and advertising, distributing, selling and/or offering for sale goods in interstate commerce that infringe Plaintiffs' Bristly Trade Dress through at least the Internet based e-commerce stores operating under the Seller IDs. Specifically, upon information and belief, Defendants are using identical copies of the Bristly Trade Dress different quality goods. Plaintiffs have used the Bristly Trade Dress extensively and continuously before Defendants began offering confusing similar imitations of Plaintiffs' merchandise. Defendants' have also used Plaintiffs' copyrighted photographs and/or common law BRISTLY trademark while marketing their knock-off products in a willful attempt to pass off their knock-off products as genuine BRISTLYTM products.

30. Upon information and belief, Defendants' Infringing Products are of a quality substantially and materially different than that of Plaintiffs' genuine goods. Defendants, upon information and belief, are actively using, promoting and otherwise advertising, distributing, selling, and/or offering for sale substantial quantities of their Infringing Products with the knowledge and intent that such goods will be mistaken for the genuine high quality goods offered for sale by Plaintiffs despite Defendants' knowledge that they are without authority to use the Bristly Trade Dress, the Bristly Mark, and Plaintiffs' copyrighted photographs. The net effect of Defendants' actions will cause confusion of consumers, at the time of initial interest, sale, and in the post-sale setting, who will believe Defendants' Infringing Products are genuine goods originating from, associated with, and approved by Plaintiff.

31. Defendants advertise their Infringing Products for sale to the consuming public via Internet based e-commerce stores on, at least, one Internet marketplace using at least the Seller IDs. In so advertising these goods, Defendants improperly and unlawfully use the Bristly Trade Dress at least one or more of the Bristly Mark or Plaintiffs' copyrighted photographs without Plaintiffs' permission.

32. As part of their overall infringement and counterfeiting scheme, Defendants are, upon information and belief, concurrently employing and benefitting from substantially similar, advertising and marketing strategies based, in large measure, upon an illegal use of infringements of the Bristly Trade Dress, Bristly Mark, and Bristly Works. Specifically, Defendants are using infringements of Plaintiffs' Bristly Trade Dress, Bristly Mark, and Bristly Works in order to make their e-commerce stores selling illegal goods appear more relevant and attractive to consumers online. By their actions, Defendants are contributing to the creation and maintenance of an illegal marketplace operating in parallel to the legitimate marketplace for Plaintiffs' genuine goods. Defendants are causing, individual, concurrent and indivisible harm to Plaintiffs and the consuming public by (i) depriving Plaintiffs and other third parties of their right to fairly compete for space within search engine results and reducing the visibility of Plaintiffs' genuine goods on the World Wide Web, (ii) causing an overall degradation of the value of the goodwill associated with the Bristly Trade Dress, Bristly Mark, and Bristly Works, and (iii) increasing Plaintiffs' overall cost to market its goods and educate consumers about its brand via the Internet.

33. Upon information and belief, Defendants are concurrently targeting their infringing activities toward consumers and causing harm within this district and elsewhere throughout the

United States. As a result, Defendants are defrauding Plaintiffs and the consuming public for Defendants' own benefit.

34. Plaintiffs confirmed that Defendants were and/or are still currently offering for sale and/or selling Infringing Products for sale to the consuming public via Internet based e-commerce stores on, at least, one Internet marketplace using at least the Seller IDs and that Defendants provide shipping and/or have actually shipped Infringing Products to customers located within this judicial district.

35. There is no question that the Infringing Product itself and the manner in which it is marketed is designed to confuse and mislead consumers into believing that they are purchasing Plaintiffs' BRISTLY™ Product or that the Infringing Product is otherwise approved by or sourced from Plaintiffs, thereby trading on the goodwill and reputation of Plaintiffs by engaging in the unauthorized use of at least one of the Bristly Trade Dress, Bristly Mark, and Bristly Works.

36. Upon information and belief, at all times relevant hereto, Defendants in this action had full knowledge of Plaintiffs' ownership of the Bristly Trade Dress, Bristly Mark, and Bristly Works, including their exclusive right to use and license such intellectual property and the goodwill associated therewith.

37. Defendants' use of the Bristly Trade Dress, Bristly Mark, and Bristly Works, including the promotion and advertisement, reproduction, distribution, sale, and offering for sale of their Infringing Products, is without Plaintiffs' consent or authorization.

38. Defendants are engaging in the above-described illegal infringing activities knowingly and intentionally or with reckless disregard or willful blindness to Plaintiffs' rights

for the purpose of trading on Plaintiffs' goodwill and reputation. If Defendants' intentional infringing activities are not preliminarily and permanently enjoined by this Court, Plaintiffs and the consuming public will continue to be harmed.

39. Defendants' above identified infringing activities are likely to cause confusion, deception, and mistake in the minds of consumers before, during, and after the time of purchase. Moreover, Defendants' wrongful conduct is likely to create a false impression and deceive customers, the public, and the trade into believing there is a connection or association between Plaintiffs' genuine goods and Defendants' Infringing Goods, which there is not.

40. Upon information and belief, Defendants' payment and financial accounts are being used by Defendants to accept, receive, and deposit profits from Defendants' infringing and unfairly competitive activities connected to their Seller IDs and any other alias e-commerce stores, photo albums, seller identification names, domain names, or websites being used and/or controlled by them.

41. Further, upon information and belief, Defendants are likely to transfer or secret their assets to avoid payment of any monetary judgment awarded to Plaintiffs.

42. Plaintiffs have no adequate remedy at law.

43. Plaintiffs are suffering irreparable injury and have suffered substantial damages as a result of Defendants' unauthorized and wrongful use of the Bristly Trade Dress, Bristly Mark, and Bristly Works. If Defendants' infringing and unfairly competitive activities are not preliminarily and permanently enjoined by this Court, Plaintiffs and the consuming public will continue to be harmed.

44. The harm and damages sustained by Plaintiffs have been directly and proximately caused by Defendants' wrongful reproduction, use, advertisement, promotion, offers to sell, and sale of their Infringing Products.

COUNT I – FEDERAL UNFAIR COMPETITION (15 U.S.C. § 1125(a))

45. Plaintiffs hereby adopt and re-allege the allegations set forth in the preceding paragraphs as if set forth herein.

46. Upon information and belief, Defendants' Infringing Products bearing, offered for sale, and sold using copies of at least one of the Bristly Trade Dress, Bristly Mark, and Bristly Works have been widely advertised and offered for sale throughout the United States via at least one fully interactive Internet marketplace.

47. Defendants' Infringing Products bearing, offered for sale, and sold using copies of at least one of the Bristly Trade Dress, Bristly Mark, and Bristly Works are virtually identical in appearance to Plaintiffs' genuine goods. Defendants' Infringing Products, however, are different and likely inferior in quality. Accordingly, Defendants' activities are likely to cause confusion in the trade and among the general public as to at least the origin or sponsorship of their Infringing Products.

48. Defendants, upon information and belief, have used in connection with their advertisement, offer for sale, and sale of their Infringing, false designations of origin and false descriptions and representations, including words or other symbols and trade dress, which tend to falsely describe or represent such goods and have caused such goods to enter into with full knowledge of the falsity of such designations of origin and such descriptions and representations, all to Plaintiffs' detriment.

49. Defendants have authorized infringing uses of at least one of the Bristly Trade Dress, Bristly Mark, and Bristly Works in Defendants' advertisement and promotion of their Infringing Products. Defendants have misrepresented to members of the consuming public that the Infringing Products being advertised and sold by them are genuine, non-infringing goods.

50. Additionally, Defendants are using infringements of the Bristly Trade Dress, Bristly Mark, and Bristly Works in order to unfairly compete with Plaintiffs and others for space within search engine organic results, thereby jointly depriving Plaintiffs of a valuable marketing and educational tool which would otherwise be available to Plaintiffs and reducing the visibility of Plaintiffs' genuine goods on the World Wide Web.

51. Defendants' above-described actions are in violation of Section 43(a) of the Lanham Act, 15 U.S.C. § 1125(a).

52. Plaintiffs have no adequate remedy at law, and have sustained indivisible injury and damage caused by Defendants' concurrent conduct. Absent an entry of an injunction by this Court, Defendants will continue to wrongfully reap profits and Plaintiffs will continue to suffer irreparable injury to its goodwill and business reputation, as well as monetary damages.

53. Based on Defendants' wrongful conduct, Plaintiffs are entitled to injunctive relief, Plaintiffs' actual damages and Defendants' profits in an amount to be proven at trial, enhanced discretionary damages for willful infringement, and reasonable attorneys' fees and costs.

COUNT II – FEDERAL COPYRIGHT INFRINGEMENT (17 U.S.C. § 501(a))

54. Plaintiffs hereby adopt and re-allege the allegations set forth in the preceding paragraphs as if set forth herein.

55. Plaintiffs are the exclusive owner and licensee of the Bristly Works.

56. Defendants had actual notice of Plaintiffs' exclusive rights in and to the Bristly Works.

57. Defendants did not attempt and therefore inherently failed to obtain Plaintiffs' consent or authorization to use, manufacture, reproduce, copy, display, prepare derivative works of, distribute, sell, transfer, rent, perform and/or market Plaintiffs' Bristly Works.

58. Without permission, Defendants knowingly and intentionally reproduced, copied, and displayed the Bristly Works by manufacturing, importing, exporting, advertising, marketing, promoting, distributing, displaying, offering for sale and/or selling products that utilize artwork that is, at a minimum, substantially similar to the Bristly Works.

59. Defendants' unlawful and willful action as alleged herein constitute infringement of the Bristly Works, including Plaintiffs' exclusive rights to reproduce, distribute and/or sell such Bristly Works in violation of 17 U.S.C. § 501(a).

60. Defendants' knowing and intentional copyright infringement, as alleged herein, has caused substantial and irreparable harm to Plaintiffs in an amount as yet unknown but to be proven at trial, for which Plaintiffs have no adequate remedy at law, and unless enjoined, Defendants will continue to cause substantial and irreparable harm to Plaintiff.

61. Based on Defendants' wrongful conduct, Plaintiffs are entitled to injunctive relief, Plaintiffs' actual damages and Defendants' profits in an amount to be proven at trial, enhanced discretionary damages for willful copyright infringement, and reasonable attorneys' fees and costs.

COUNT III - COMMON LAW UNFAIR COMPETITION

62. Plaintiffs hereby adopt and re-allege the allegations set forth in the preceding paragraphs as if set forth herein.

63. This is an action against Defendants based on their promotion, advertisement, distribution, sale, and/or offering for sale of goods bearing and/or using marks that are virtually identical, both visually and phonetically, to one or more of the Bristly Trade Dress, Bristly Mark, and Bristly Works in violation of Pennsylvania's common law of unfair competition.

64. Specifically, Defendants are promoting and otherwise advertising, selling, offering for sale, and distributing goods bearing and/or using infringements of one or more of the Bristly Trade Dress, Bristly Mark, and Bristly Works. Defendants are also using infringements of one or more of the Bristly Trade Dress, Bristly Mark, and Bristly Works to unfairly compete with Plaintiffs and others on Internet marketplaces, for space in search results across an array of search terms, and visibility on the World Wide Web.

65. Defendants' infringing activities are likely to cause and actually are causing confusion, mistake, and deception among members of the trade and the general consuming public as to the origin and quality of Defendants' products by their use of one or more of the Bristly Trade Dress, Bristly Mark, and Bristly Works.

66. Plaintiffs have no adequate remedy at law and are suffering irreparable injury and damages as a result of Defendants' actions.

67. As a result of Defendants' actions alleged herein, Plaintiffs are entitled to injunctive relief, an order granting Plaintiffs' damages and Defendants' profits stemming from their infringing activities, and exemplary or punitive damages for Defendants' intentional misconduct.

COUNT IV - COMMON LAW TRADEMARK INFRINGEMENT

68. Plaintiffs hereby adopt and re-allege the allegations set forth in the preceding paragraphs as if set forth herein.

69. This is an action for common law trademark infringement against Defendants based on their promotion, advertisement, offering for sale, and sale of their Infringing Products bearing and/or using at least one of the Bristly Trade Dress and Bristly Mark. Plaintiffs are the exclusive licensee and owner of all common law rights in and to the Bristly Trade Dress and Bristly Mark.

70. Specifically, Defendants, upon information and belief, are manufacturing, promoting and otherwise advertising, distributing, offering for sale, and selling goods bearing and/or using infringements of at least one of the Bristly Trade Dress and Bristly Mark.

71. Defendants' infringing activities are likely to cause and actually are causing confusion, mistake and deception among members of the trade and the general consuming public as to the origin and quality of Defendants' Products bearing and/or using at least one of the Bristly Trade Dress and Bristly Mark.

72. Plaintiffs have no adequate remedy at law and is suffering damages and irreparable injury as a result of Defendants' actions.

PRAYER FOR RELIEF

WHEREFORE, Plaintiffs demands judgment on all Counts of this Complaint and an award of equitable relief and monetary relief against Defendants as follows:

a. Entry of temporary, preliminary and permanent injunctions pursuant to 15 U.S.C. § 1116, and 17 U.S.C. § 502, and Federal Rule of Civil Procedure 65 enjoining Defendants, their agents, representatives, servants, employees, and all those acting in concert or participation

therewith, from manufacturing or causing to be manufactured, importing, advertising or promoting, distributing, selling or offering to sell their Infringing Products; from infringing, or diluting the Bristly Trade Dress, Bristly Mark, and Bristly Works; from using the Bristly Trade Dress, Bristly Mark, and Bristly Works, or any mark or trade dress similar thereto, in connection with the sale of any unauthorized goods; from using any logo, trade name or trademark or trade dress that may be calculated to falsely advertise the services or goods of Defendants as being sponsored by, authorized by, endorsed by, or in any way associated with Plaintiffs; from falsely representing themselves as being connected with Plaintiffs, through sponsorship or association, or engaging in any act that is likely to falsely cause members of the trade and/or of the purchasing public to believe any goods or services of Defendants are in any way endorsed by, approved by, and/or associated with Plaintiffs; from using any reproduction, counterfeit, infringement, copy, or colorable imitation of the Bristly Trade Dress, Bristly Mark, and Bristly Works or substantially similar copy of the Bristly Work in connection with the publicity, promotion, sale, or advertising of any goods sold by Defendants; from affixing, applying, annexing or using in connection with the sale of any goods, a false description or representation, including words or other symbols tending to falsely describe or represent Defendants' goods as being those of Plaintiffs, or in any way endorsed by Plaintiffs and from offering such goods in commerce; from engaging in search engine optimization strategies using colorable imitations of the Bristly Trade Dress, Bristly Mark, and Bristly Works; from further infringement, or use of a substantially similar copy of the Bristly Work; and from otherwise unfairly competing with Plaintiffs.

c. Entry of an Order that, upon Plaintiffs' request, any Internet marketplace website operators and/or administrators that are provided with notice of the injunction, including but not

limited to the online marketplaces hosted by eBay.com, identify any e-mail address known to be associated with Defendants' respective Seller ID, and cease facilitating access to any or all e-commerce stores through which Defendants engage in the promotion, offering for sale, and/or sale of goods bearing and/or using counterfeits and/or infringements of the Bristly Trade Dress, Bristly Mark, and Bristly Works and/or a substantially similar copy of the Bristly Works.

d. Entry of an Order that, upon Plaintiffs' request, any Internet marketplace website operators and/or administrators who are provided with notice of the injunction, including but not limited to online marketplaces hosted by eBay.com, permanently remove any and all listings and associated images of goods bearing and/or using counterfeits and/or infringements of the Bristly Trade Dress, Bristly Mark, and Bristly Works or substantially similar copies of the Bristly Works via the e-commerce stores operating under the Seller IDs, including any and all listings and images of goods bearing and/or using counterfeits and/or infringements of the Bristly Trade Dress, Bristly Mark, and Bristly Works and/or a substantially similar copy of the Bristly Works linked to the same seller or linked to any other alias seller identification name being used and/or controlled by Defendants to promote, offer for sale and/or sell goods bearing and/or using counterfeits and/or infringements of the Bristly Trade Dress, Bristly Mark, and Bristly Works and/or substantially similar copy of the Bristly Works.

e. Entry of an Order that, upon Plaintiffs' request, any Internet marketplace website operators and/or administrators who are provided with notice of the injunction, including but not limited to online marketplaces hosted eBay.com, immediately cease fulfillment of and sequester all goods of each Defendant or other Seller under a Seller ID bearing and/or using one or more of the Bristly Trade Dress, Bristly Mark, and Bristly Works and/or a substantially similar copy of

the Bristly Works in its inventory, possession, custody, or control, and surrender those goods to Plaintiffs.

f. Entry of an order requiring Defendants to account to and pay Plaintiffs for all profits and damages resulting from Defendants' and infringing and unfairly competitive activities and that the award to Plaintiffs be trebled, as provided for under 15 U.S.C. §1117.

g. Entry of an award pursuant to 15 U.S.C. § 1117 (a) and (b) of Plaintiffs' costs and reasonable attorneys' fees and investigative fees associated with bringing this action.

h. For an award of Plaintiffs' actual damages and Defendants' profits, pursuant to 17 U.S.C. § 504(b), in an amount to be proven at trial for willful copyright infringement of the Bristly Works under § 501(a).

i. In the alternative to Plaintiffs' actual damages and Defendants' profits for copyright infringement of the Bristly Works pursuant to 17 U.S.C. § 504(b), for statutory damages of \$150,000.00 per infringement pursuant to 17 U.S.C. § 504(c) for willful copyright infringement, which Plaintiffs may elect prior to rendering of final judgment, together with Plaintiffs' costs and reasonable attorneys' fees and investigative fees associated with bringing this action.

j. Entry of an Order that, upon Plaintiffs' request, any financial institutions, payment processors, banks, escrow services, money transmitters, or marketplace platforms, including but not limited to, eBay, Inc. d/b/a eBay.com ("eBay") and PayPal, Inc. d/b/a paypal.com ("PayPal"), and their related companies and affiliates, identify and restrain all funds, up to and including the total amount of judgment, in all financial accounts and/or sub-accounts used in connection with the Seller IDs or other domain names, alias seller identification names, or e-commerce store names or store URLs used by Defendants presently or in the future, as well as

any other related accounts of the same customer(s) and any other accounts which transfer funds into the same financial institution account(s), to be surrendered to Plaintiffs in partial satisfaction of the monetary judgment entered herein.

k. Entry of an award of pre-judgment interest on the judgment amount.

l. Entry of an order for any further relief as the Court may deem just and proper.

DEMAND FOR JURY TRIAL

Plaintiffs respectfully demand a trial by jury on all claims.

Respectfully submitted,

June 24, 2019

/s/ Stanley D. Ference III

Stanley D. Ference III

Pa. ID No. 59899

courts@ferencelaw.com

Brian Samuel Malkin

Pa. ID No. 70448

bmalkin@ferencelaw.com

FERENCE & ASSOCIATES LLC

409 Broad Street

Pittsburgh, Pennsylvania 15143

(412) 741-8400 - Telephone

(412) 741-9292 - Facsimile

Attorneys for Plaintiffs

Doggie Dental, Inc. and

Peter Dertsakyan

SCHEDULE "A"
DEFENDANTS BY STORENAME AND STORE NUMBER

Defendant No.	Defendant/ eBay Seller Name	eBay Item No.
1	max_buy	283260359301 273784204706 283250774663
2	adamchahir91	173621663654
3	airaka	283314176449
4	chmysm2018	312582286181
5	chinacostco_com	401640749164
6	cute-little-bear	283429929853
7	dc_bigshop1	332871800517 233023661242
8	deals4you9	142946752219
9	dedicatedsalesman	113291620121
10	good.deals411	401727604162
11	hantetech	153460905493
12	malifa168	254193025258
13	parts_online_2015	333134236938
14	shengxinyide2019new	163661202341
15	shopiline	143070043285
16	songyupeng1	372520429328 401631019715 401648408725 372520031376
17	4dice_international	113719563861
18	15oceaneshop	133016438995
19	a281768443	123728836755
20	adore-mart	273771923418

Defendant No.	Defendant/ eBay Seller Name	eBay Item No.
21	aldopets	173859442414
22	awesome*deals*today	264257214090
23	bigsquireland	223443866206
24	boris11184	123406003014
25	cashow002	264238330272 263996819056
26	chawtabu0	333152522862 333152558517
27	crab-store	132917299708
28	dd2004720	163648416417
29	electronic_accessory_sales15	113383727885 113383725017
30	etrackonline	382631376693
31	global-onlineshop	192875156977
32	good_gol	173853506737
33	hanguang2018	183570344990 183594630051
34	happy2shopping2014	254014031904
35	happy-shop09	223457967046
36	homca2018	333151368645
37	home-store01	192877988183
38	ilovehome2018	153397186403
39	jaman38	192880268711
40	jostegen0	303047473519
41	lagacreye	264247037577 264247044239
42	letsboomboom	202496064579
43	ludas_mb	223461320615
44	mai202	392262076927
45	makdeep_0	123656394706
46	miggie77392012	183524497018

Defendant No.	Defendant/ eBay Seller Name	eBay Item No.
		183568259837
47	nununy3090	233100866536
48	nutrasil	173831912125
49	oxwelle	253908289202
50	oz-sweetdeals	132987937936
51	paradisestore12	123689950279
52	parmesan_cliche	254136633195 254137985242 254137941237 254136632680 254137510050
53	parsayt0	323760244487
54	pha_6296	401732550025
55	plussale2017	183741229962
56	poramatse	143137777670
57	pricenter-ksdy	352642114979
58	qich97	273692053753
59	ralliant401	264281748175
60	rchcommerce1	163648213563
61	rebel1964	183749655490
62	redflower88	192864978584
63	ricji-45	312460809336
64	roberttaylor1589	352653064435
65	savvy-variety-shop	303119683035
66	sellingdaily90	293068665207
67	shopmallclub14	292868640649
68	slayway	372601630606 372601629978
69	sunfurax1	303022558695

Defendant No.	Defendant/ eBay Seller Name	eBay Item No.
70	tabletassembliesales1	254010266311 253990923200 253992995969
71	thph_5710	133021409411
72	timetree88	352625751236
73	towardfor	333126679945
74	truthedge.tech	173861733853
75	uleader666	362581659545
76	us2014.runzh	254095575455
77	usa.best.buying.experience	183681120066 183680993414
78	usa_ezra	273779162823
79	vejusshop17	192818928575
80	warehousedeals365	233119934769 382765057237
81	wewell888	223445427573
82	yair_uza	254181832584
83	yambaystore	123688194538
84	yvsg7734	163479765919
85	allcommerce27	173873059719
86	bruceshark-003	254206435700
87	chuanhu-store	382868561129
88	daos_34	372655989805
89	elshm_23	382855286796
90	excelsellerusa	233202722712
91	gohastings	382909773600
92	japanmarketplace	153397624294
93	ljsuperiorchew	163605701520
94	lucid-dreams	233203320927
95	lxlspets	192877443124 92877442677

Defendant No.	Defendant/ eBay Seller Name	eBay Item No.
96	maexus2018	303114565917
97	oobest_shop	123690828930
98	pege-318	202660041223
99	peninsulahome	223452646909
100	power-option	254033147886
101	presst_55	392187927096
102	ramah76m9	382911102525
103	raysal_64	143224397484
104	rm_best_4u	163549164611
105	saveyourbuy	333122249547
106	sedra-mb	264272772825
107	shimi_di	254207244054
108	simshop2018	323499684952
109	smartshopper2018	192877281447
110	soonhua2010	392267370872
111	thebusybunny	303134296865
112	uniquely_dg	233145027936
113	vestut-56	143222917427
114	violetrosech	323644254194

LISTING OF EXHIBITS

- Exhibit 1.....U.S. Copyright Reg. No. VA 2-122-455 for “Photos of In Use
Pet/Dog Toy for Oral Hygiene”
- Exhibit 2.....Publication Confirmation for U.S. Trademark Application Serial
No. 88/177,120 for BRISTLY
- Exhibit 3.....European Registered Community Design No. 005818606-0001
- Exhibit 4.....U.S. Patent Application Publication No. 2018/0295811

EXHIBIT 1

Certificate of Registration



This Certificate issued under the seal of the Copyright Office in accordance with title 17, *United States Code*, attests that registration has been made for the work identified below. The information on this certificate has been made a part of the Copyright Office records.

Registration Number

VA 2-122-455

Effective Date of Registration:

September 27, 2018

Handwritten signature of Kay A. Leahy in black ink.

Acting United States Register of Copyrights and Director

Title

Title of Work: Photos of In Use Pet/Dog Toy For Oral Hygiene

Completion/Publication

Year of Completion: 2018
Date of 1st Publication: June 20, 2018
Nation of 1st Publication: United States

Author

- Author: Petros Dertsakyan
Author Created: photograph, 2-D artwork
Citizen of: United States
Domiciled in: United States
Year Born: 1987

Copyright Claimant

Copyright Claimant: Petros Dertsakyan
7700 Babcock Ave., North Hollywood, CA, 91605, United States
Transfer statement: author is claimant

Limitation of copyright claim

Material excluded from this claim: sculpture
New material included in claim: photograph, 2-D artwork

Rights and Permissions

Organization Name: David R. Preston, Ph.D., J.D., APC
Name: David Preston
Email: preston@drpna.com
Telephone: (858)724-0375
Alt. Telephone: (858)735-7132

Address: 10765 Wallingford Road
San Diego, CA 92126 United States

Certification

Name: David R. Preston
Date: September 27, 2018
Applicant's Tracking Number: DOGD-106.C.3

Correspondence: Yes
Copyright Office notes: Basis for Registration: Unit of publication



Deposit Materials



Natural Rubber
with Meat Flavor



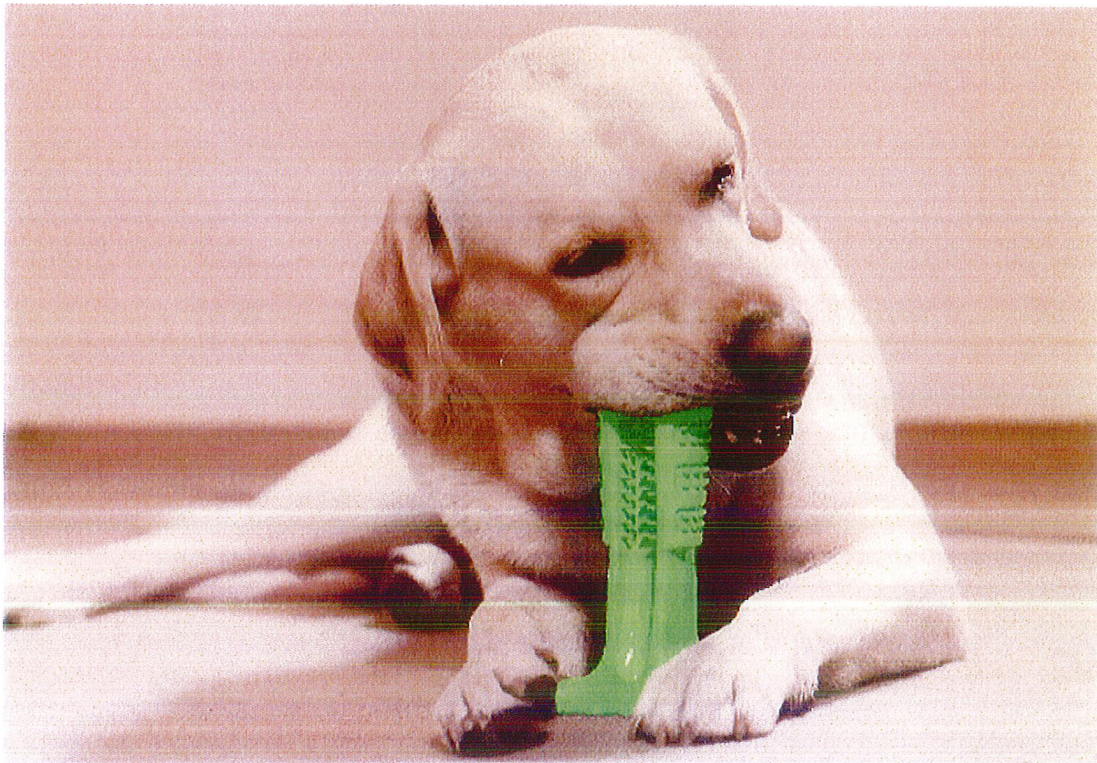
Gentle, while
Highly Durable



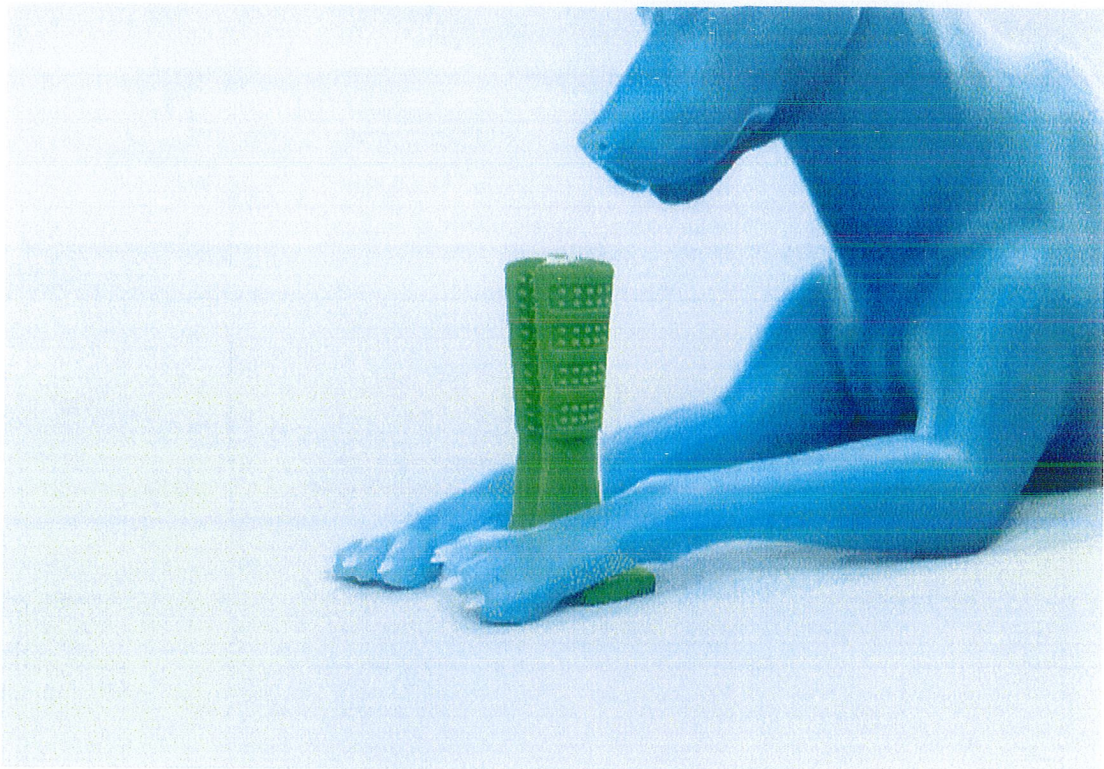
Designed
& Developed
in the USA



Complies with
the US Child Toy
Safety Standards







Bristly
by Empower

WE ARE
LIVE
NOW
ON
KICKSTARTER



EXHIBIT 2

From: TMOOfficialNotices@USPTO.GOV
Sent: Tuesday, March 26, 2019 01:09 AM
To: adriano@toblerlawfirm.com
Subject: Official USPTO Notice of Publication Confirmation: U.S. Trademark SN 88177120: BRISTLY

TRADEMARK OFFICIAL GAZETTE PUBLICATION CONFIRMATION

U.S. Serial Number: 88177120
Mark: BRISTLY
International Class(es): 003
Owner: Dertsakyan, Peter
Docket/Reference Number:

The mark identified above has been published in the Trademark Official Gazette (TMOG) on Mar 26, 2019.

To Review the Mark in the TMOG:

Click on the following link or paste the URL into an internet browser: <https://tmog.uspto.gov/#issueDate=2019-03-26&serialNumber=88177120>

On the publication date or shortly thereafter, the applicant should carefully review the information that appears in the TMOG for accuracy. If any information is incorrect due to USPTO error, the applicant should immediately email the requested correction to TMPostPubQuery@uspto.gov. For applicant corrections or amendments after publication, please file a post publication amendment using the form available at <http://teasroa.uspto.gov/ppaf/>. For general information about this notice, please contact the Trademark Assistance Center at 1-800-786-9199.

Significance of Publication for Opposition:

- * Any party who believes it will be damaged by the registration of the mark may file a notice of opposition (or extension of time therefor) with the Trademark Trial and Appeal Board. If no party files an opposition or extension request within thirty (30) days after the publication date, then eleven (11) weeks after the publication date a notice of allowance (NOA) should issue. (Note: The applicant must file a complete Statement of Use or Extension Request with the required fees within six (6) months after the NOA issues to avoid abandonment of the application.)

To check the status of the application, go to http://tsdr.uspto.gov/#caseNumber=88177120&caseType=SERIAL_NO&searchType=statusSearch or contact the Trademark Assistance Center at 1-800-786-9199. Please check the status of the application at least every three (3) months after the application filing date.

To view this notice and other documents for this application on-line, go to http://tsdr.uspto.gov/#caseNumber=88177120&caseType=SERIAL_NO&searchType=documentSearch. NOTE: This notice will only become available on-line the next business day after receipt of this e-mail.

EXHIBIT 3

Registered / Eingetragen 07/11/2018

No 005818606-0001



EUROPEAN UNION INTELLECTUAL
PROPERTY OFFICE
CERTIFICATE OF REGISTRATION

This Certificate of Registration is hereby issued for the
Registered Community Design identified below. The
corresponding entries have been recorded in the
Register of Community Designs.

AMT DER EUROPÄISCHEN UNION FÜR
GEISTIGES EIGENTUM
EINTRAGUNGSRKUNDE

Diese Eintragungsurkunde wird für das unten genannte
eingetragene Gemeinschaftsgeschmacksmuster
ausgestellt. Die entsprechenden Einträge sind in das
Register für Gemeinschaftsgeschmacksmuster
aufgenommen worden.

The Executive Director / Der
Exekutivdirektor

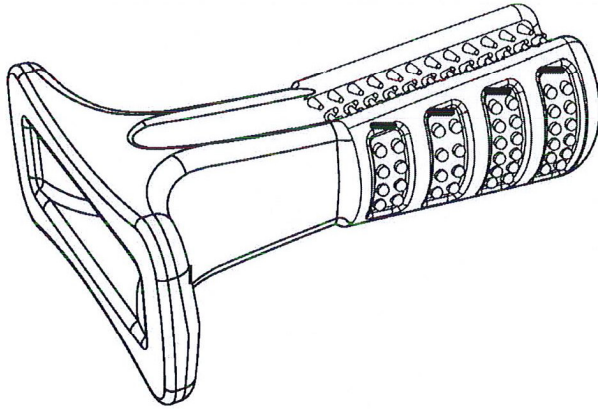
Christian Archambeau

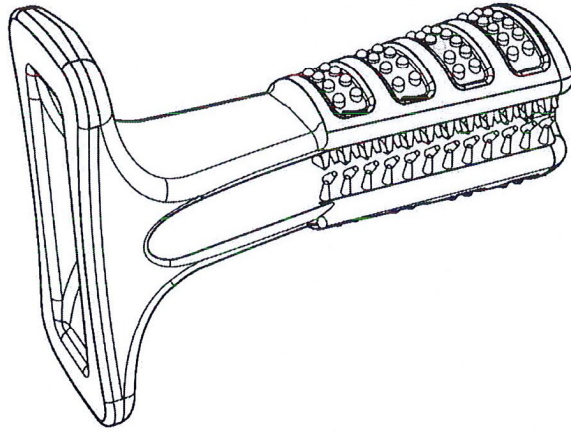


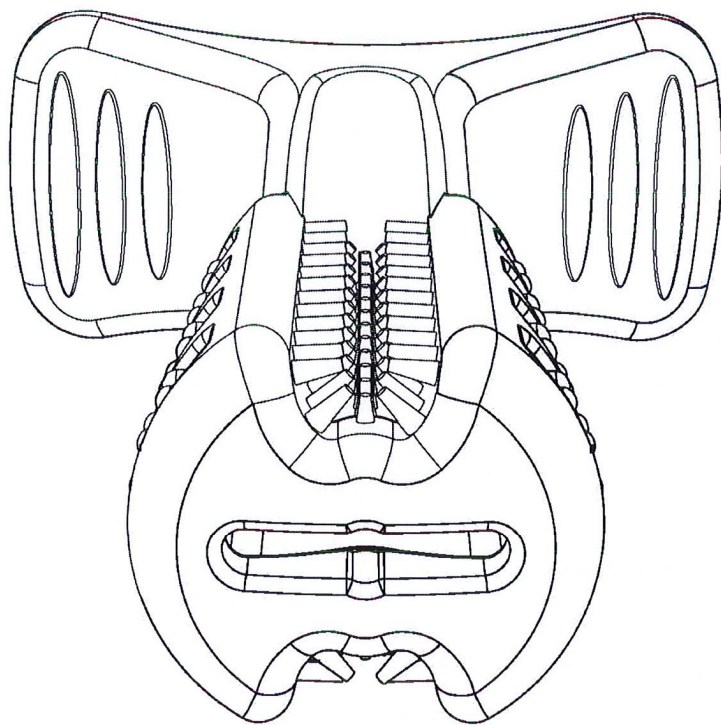
www.euiipo.europa.eu

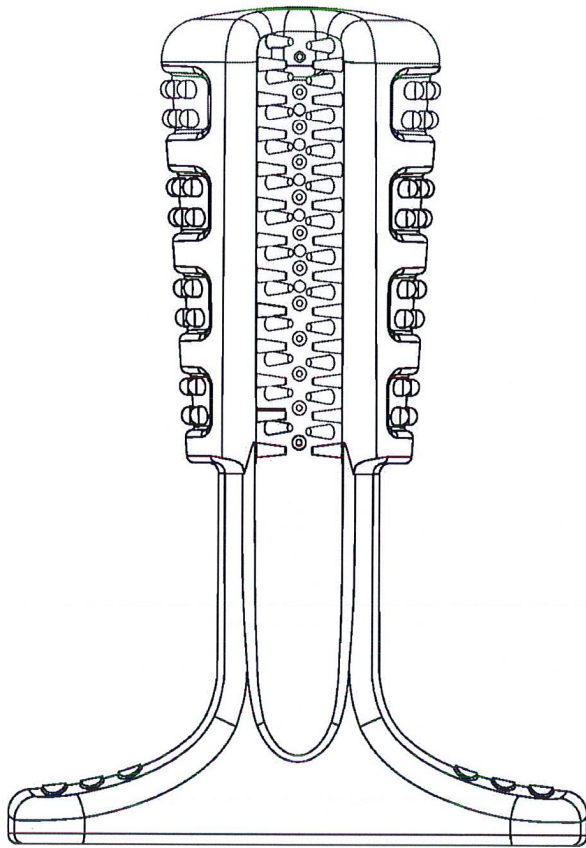


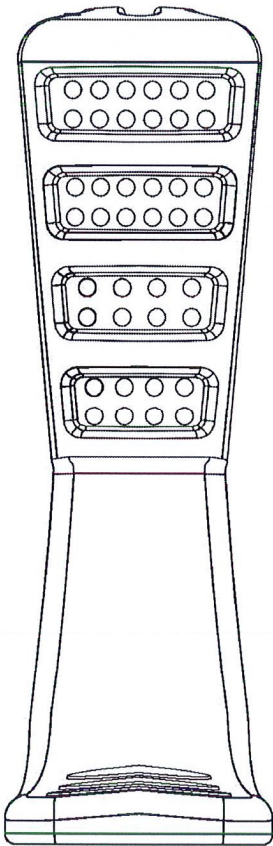
21 005818606-0001
25 EN - DE
22 07/11/2018
15 07/11/2018
45 15/01/2019
11 005818606-0001
73 Peter Dertsakyan
7700 Babcock Avenue
North Hollywood California 91605
ESTADOS UNIDOS (DE AMÉRICA)
74 SCHAUMBURG UND PARTNER PATENTANWÄLTE MBB
Mauerkircherstr. 31
D-81679 München
ALEMANIA
51 30 - 99
54 BG - Играчки за животни
ES - Juguetes para animales
CS - Hračky pro zvířata
DA - Legetøj til dyr
DE - Spielzeug für Tiere
ET - Loomamänguasjad
EL - Παιχνίδια για ζώα
EN - Toys for animals
FR - Jouets pour animaux
IT - Giocattoli per animali
LV - Dzīvnieku rotaļlietas
LT - Gvūnų žaislai
HR - Igračke za životinje
HU - Játékok állatoknak
MT - Ġugarelli għall-annimali
NL - Speelgoed voor dieren
PL - Zabawki dla zwierząt
PT - Brinquedos para animais
RO - Jucării pentru animale
SK - Hračky pre zvieratá
SL - Igrače za živali
FI - Eläinten lelut
SV - Djurleksaker
30 US - 18/09/2018 - 29/663,715
57
55

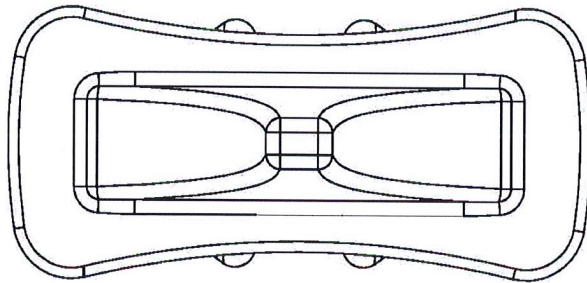












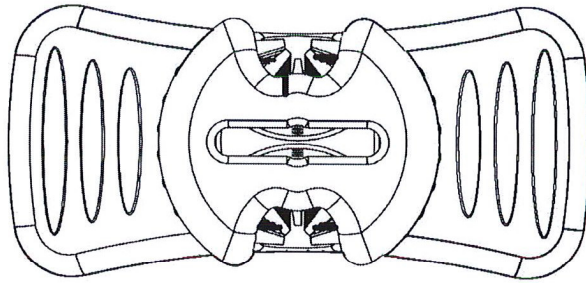


EXHIBIT 4



US 20180295811A1

(19) **United States**

(12) **Patent Application Publication**
Dertsakyan

(10) **Pub. No.: US 2018/0295811 A1**
(43) **Pub. Date: Oct. 18, 2018**

(54) **PET CHEW TOY FOR DENTAL
SELF-CLEANING BY DOMESTIC PETS**

(52) **U.S. Cl.**
CPC *A01K 15/026* (2013.01); *A46B 9/026*
(2013.01)

(71) Applicant: **Petros Dertsakyan**, North Hollywood,
CA (US)

(57) **ABSTRACT**

(72) Inventor: **Petros Dertsakyan**, North Hollywood,
CA (US)

(21) Appl. No.: **15/472,206**

(22) Filed: **Mar. 28, 2017**

Publication Classification

(51) **Int. Cl.**
A01K 15/02 (2006.01)

A pet chew toy allowing for the self-cleaning of teeth by domestic pets. The pet toy includes one or more cavities into which a pet's teeth may engage, and the inner and outer surfaces of the cavities may have scrubbing elements designed to enhance removal of plaque and other unhygienic products from a pet's teeth and gums. The chew toy may further include projections to enhance stabilization of the chew toy by the pet, and a reservoir and dispensing system for pet toothpaste or similar additive.

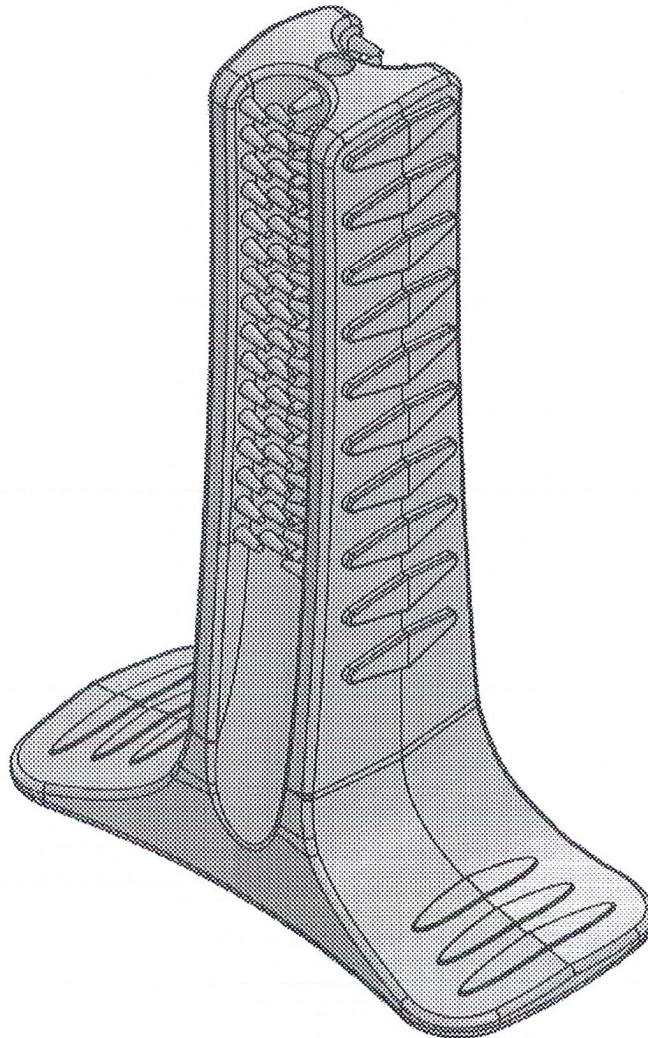
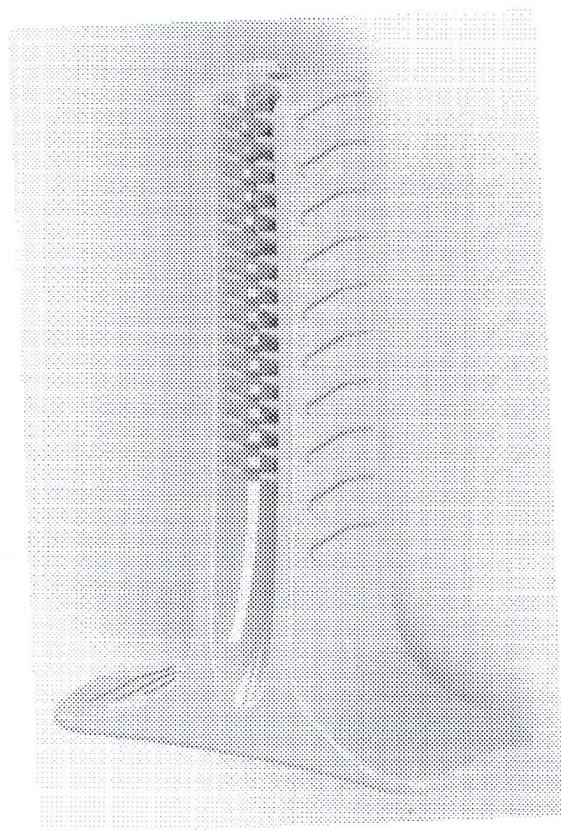


Figure 1



100

Figure 2

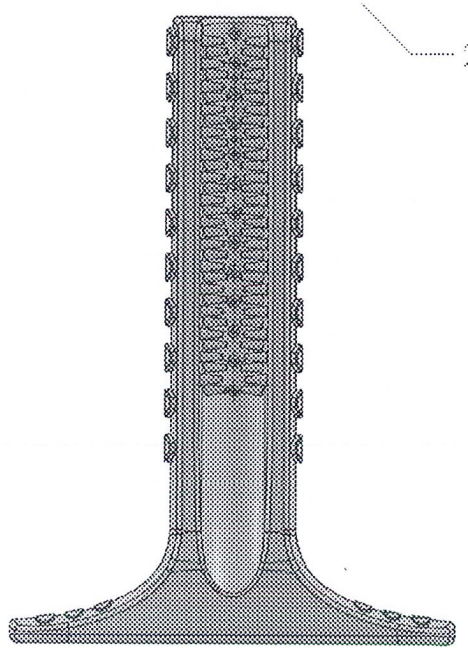


Figure 3

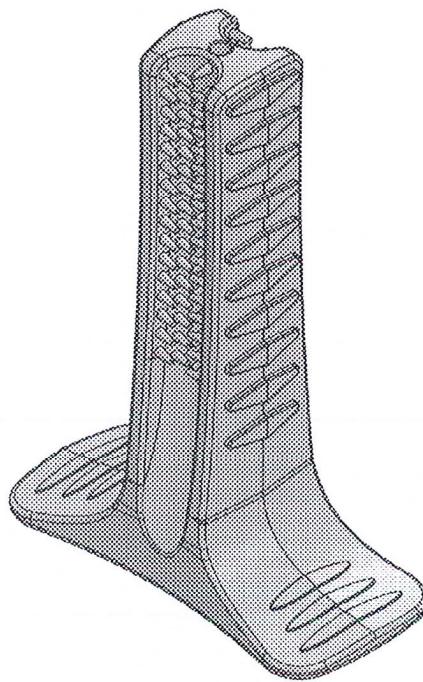


Figure 4

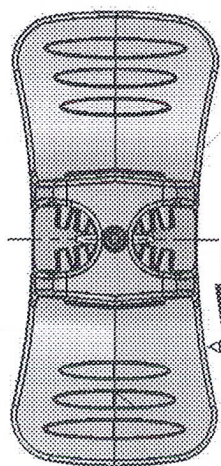


Figure 5

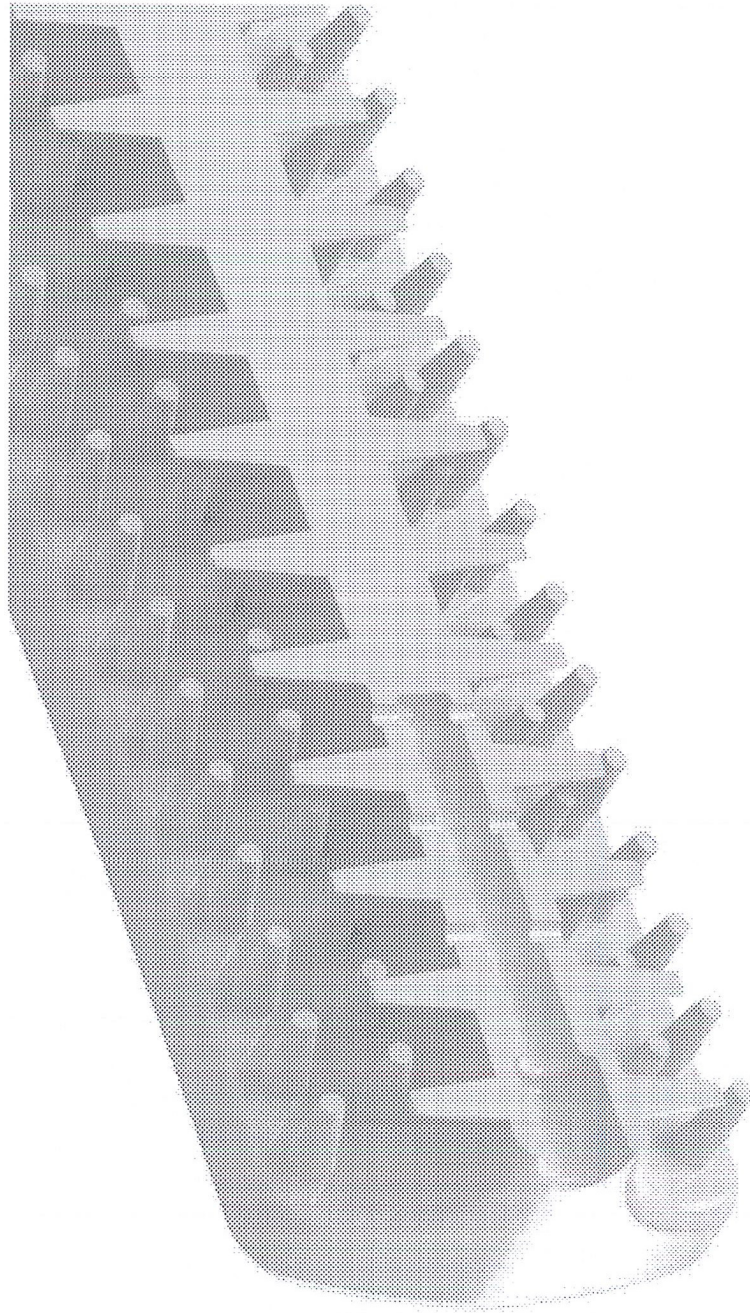
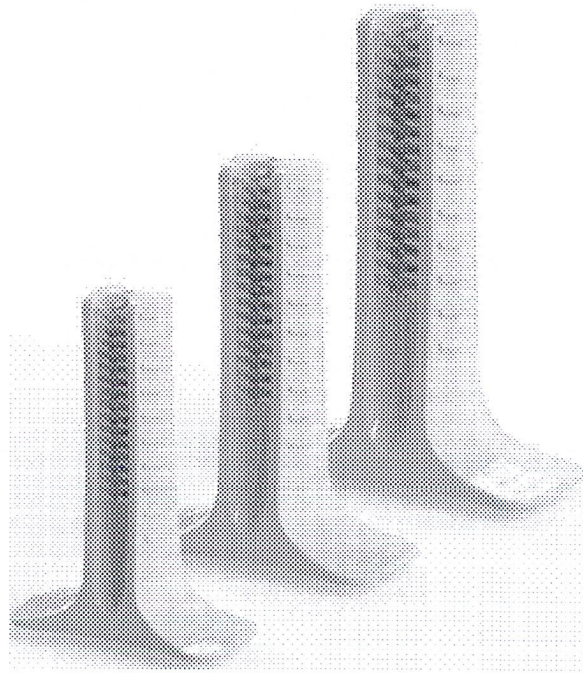


Figure 6



**PET CHEW TOY FOR DENTAL
SELF-CLEANING BY DOMESTIC PETS**

CROSS-REFERENCE TO RELATED
APPLICATIONS

[0001] The present application claims priority to provisional application 62/314,353, filed Mar. 28, 2016, entitled "Toy for a Domestic Pet to Brush Its Own Teeth" which is incorporated by reference in its entirety herein.

STATEMENT REGARDING FEDERALLY
SPONSORED RESEARCH

[0002] Not applicable.

JOINT RESEARCH AGREEMENT STATEMENT

[0003] Not applicable.

FIELD OF THE INVENTION

[0004] The present invention relates to a pet chew toy and dental hygiene system, and particularly to pet chew toy allowing for the dental self-cleaning by domestic pets.

BACKGROUND

[0005] Maintaining the dental hygiene of domestic pets is a well-known issue. Like humans, domestic pets such as dogs and cats develop bacterial infections, known generally as plaque, on the surface and in the spaces between the teeth of said pets. In addition to the malodorous breath and appearance of domestic pets suffering from an excess of plaque, it can also precipitate the gum disease gingivitis, damage to the pet's teeth, and other material detriment to the oral health of the pet. If left routinely uncleaned, it can harden and become almost impossible to remove without professional assistance.

[0006] Traditional methods of cleaning the teeth of pets has involved labor-intensive manual cleaning by the pet owner, a process which is both time-consuming and often results in unnecessary antagonism between the domestic pet and its owner.

[0007] Wild relatives of domestic pets, such as wild dogs and wolves, use the frictional effects of gnawing on bones and other hard objects to clean their teeth of plaque and residual pieces of food. The use of domestic pet chew toys as a method of mimicking these natural dental hygiene methods for domestic pets is known in the art. As a consequence, many domestic animal chews or chew toys have been produced of rawhide or other hard surface and configured in such a way as to mimic the shape and feel of natural bone. Other products have introduced additional artificial features to improve upon the natural cleaning action of a domestic pet's chewing action on bone, such as the use of additional projections on a surface of the chew toy.

[0008] Information relevant to attempts to address these problems can be found in US Patent Application No. 2004/0216693 to Handelsman; U.S. Pat. No. 6,116,119 to Suchowski; U.S. Pat. No. 6,739,287 to Sarantis; U.S. Pat. D501,961 to Jager; US Patent Application no. 2004/0137118 to Axelrod; and U.S. Pat. Nos. 8,807,088 and 7,490,579 to Axelrod. However, each one of these references suffers from one or more disadvantages. One consistent failing of existing products relates to a domestic pet's propensity to grip or hold an object between its front paws. Domestic pets will

naturally seek to stabilize the subject of their chewing action, allowing for a stronger and more satisfying engagement by the pet's mouth, while increasing the friction applied to the pet's teeth and oral cavity by the bone or chew toy. Another failing of existing products is the inability to use pet toothpaste and other supplementary dental hygiene products in conjunction with the chewing action of the chew toys. This leaves the need for supplementary manual cleaning by the domestic pet owner. Yet another disadvantage of existing products is the lack of differentiated surfaces for inner and outer domestic pet teeth. Domestic pets, such as dogs and cats, have substantially different shape and spacing in their teeth between the front of their mouths, wherein are located canines and other long, large teeth, and the smaller, more closely spaced teeth in the back of the pets' mouths. The differences in size and spacing of these teeth suggest the need for different surfaces with different textures and projections adapted to the particular needs of that portion of the domestic pet's dental structures.

[0009] For the foregoing reasons, there is a need for an improved domestic pet chew toy that allows domestic pets to clean their own teeth.

SUMMARY

[0010] The present invention is directed to an apparatus that satisfies this need.

[0011] One possible embodiment of the invention takes the form of a chew toy for use by a domestic pet such as a dog, cat or other domesticated animal. This embodiment comprises a central member for engagement of a domestic pet's oral cavity, which includes at least one inner surface defining a cavity and an outer surface, each or both of which may have a variety of scrubbing elements affixed to them.

[0012] Another possible embodiment comprises a central member for engagement of a domestic pet's oral cavity, said member having a first end and a second end. The second end further comprises one or more projections, which may be circular or otherwise shaped, which are substantially flat and oriented perpendicular to the length of the central member. The projections allow the member to be stood upright and gripped by a domestic pet, using its front paws.

[0013] Yet another possible embodiment includes a reservoir running the length of the central member of a chew toy, in which, by way of non-limiting example, flavored toothpaste for domestic pets can be retained. Smaller dispensing holes are present in the central member perpendicular to the reservoir, allowing the toothpaste or other products to be dispensed into the oral cavity of a domestic pet when the central member is engaged by said pet's oral cavity.

BRIEF DESCRIPTION OF THE DRAWINGS

[0014] These and other features, aspects, and advantages of the present invention will become better understood with reference to the following description, appended claims, and drawings where:

[0015] FIG. 1 shows an embodiment of the invention having a central member with an inner surface defining a cavity, perpendicular stabilizing projections, and a plurality of scrubbing elements on the inner and outer surfaces of the central member.

[0016] FIG. 2 shows a side-view of an embodiment of the invention, showing the multiplicity of scrubbing elements

projecting from the inner surfaces defining the cavity, and the outer surfaces of the member.

[0017] FIG. 3 shows an embodiment of the invention wherein the central member has inner surfaces defining two separate cavities.

[0018] FIG. 4 shows a top-down view of the embodiment of FIG. 3, with the positioning for an optional additional reservoir to retain pet toothpaste shown at center.

[0019] FIG. 5 shows a lengthwise cut-away of the central member of the embodiment of FIG. 3, demonstrating the shape and positioning of the additional reservoir, and smaller perpendicular holes for dispensing toothpaste retained in said reservoir.

[0020] FIG. 6 shows a comparison between different possible sizes of an embodiment of the invention.

DETAILED DESCRIPTION

[0021] In the Summary above and in the Detailed Description, and the claims below, and in the accompanying drawings, reference is made to particular features of the invention. It is to be understood that the disclosure of the invention in this specification includes all possible combinations of such particular features. For example, where a particular feature is disclosed in the context of a particular aspect or embodiment of the invention, or a particular claim, that feature can also be used, to the extent possible, in combination with and/or in the context of other particular aspects and embodiments of the invention, and in the invention generally.

[0022] The term “comprises” and grammatical equivalents thereof are used herein to mean that other components, ingredients, steps, etc. are optionally present. For example, an article “comprising” (or “which comprises”) components A, B, and C can consist of (i.e., contain only) components A, B, and C, or can contain not only components A, B, and C but also one or more other components.

[0023] The term “at least” followed by a number is used herein to denote the start of a range beginning with that number (which may be a range having an upper limit or no upper limit, depending upon the variable being defined). For example, “at least 1” means 1 or more than 1. The term “at most” followed by a number is used herein to denote the end of a range ending with that number (which may be a range having 1 or 0 as its lower limit, or a range having no lower limit, depending upon the variable being defined). For example, “at most 4” means 4 or less than 4, and “at most 40%” means 40% or less than 40%. When, in this specification, a range is given as “(a first number) to (a second number)” or “(a first number)-(a second number),” this means a range whose lower limit is the first number and whose upper limit is the second number. For example, 25 to 100 mm means a range whose lower limit is 25 mm, and whose upper limit is 100 mm.

[0024] In one possible embodiment of the invention, as shown in FIG. 1, takes the form of a chew toy having a central member. The chew toy may be made of any suitable material, including by way of non-limiting example any non-toxic plastic. The central member comprises at least one inner surface, defining a cavity having an open end running the length of the central member and an additional open side at the top end of the central member. Said cavity should be of sufficient depth to allow full penetration by the front or back teeth of a domestic pet. The size of the central member, and therefore relative depth of the cavity, may be varied to

suit a variety of domestic pet breeds, as shown in FIG. 6. By providing inner and outer surfaces for contact with the teeth and gums of a domestic pet, faster and more complete cleaning action is achieved on the pet's teeth and gums by maximizing the area of contact and friction between the central member and the pet's teeth and gums. In addition, further cleaning action is achieved by the simultaneous contact of the surfaces of the member with the forward and inner teeth of the pet.

[0025] As shown in FIG. 2, the outer surface of the central body may have affixed to it a plurality of scrubbing elements. As also show in FIG. 2, the inner surface defining the cavity may also have affixed to it an additional plurality of scrubbing elements.

[0026] The scrubbing elements affixed to the outer and inner surfaces may vary in size and shape. By way of example, they could take the form of bristles, pyramids, cones, rectangles, or any of a variety of other desirable configurations. The scrubbing elements affixed to the outer surface of the central member might, in one possible embodiment, be of a different shape or size than the scrubbing elements affixed to the inner surface, as shown in FIG. 2. Similarly, the size and shape of the scrubbing elements affixed to the inner surface might be the same as those affixed to the outer surface of the central member. This allows the scrubbing elements to be adapted to the differential spacing, tooth shape, and mouth size of a variety of domestic pets.

[0027] A further aspect of the present invention is shown in FIG. 1, comprising the substantially flat perpendicular projections. Although the embodiment shown in FIG. 1 has the projections take the form of two flanges or separate extensions, one of skill in the art will understand that the projection or projections can take a variety of shapes and sizes. Non-limiting examples might be a singular projection forming a circular base to the central member, or a multiplicity of flanges allowing a pet to grip the projections from a variety of angles. These projections allow a pet to fully stabilize the chew toy upright using their natural gripping action with the front paws.

[0028] In contrast to the rough or knobbed ends of natural bones or typical pet chew toys, here the domestic pet can fully pin down and stabilize the central member of the chew toy such that it is fully upright and immobile. This allows for a much strong grip on the central body by the mouth of the domestic pet, increasing the friction between the surface of the chew toy and the pet's teeth. This allows for superior cleaning and removal of plaque, leftover food, and other detrimental material from the mouth of the pet.

[0029] Yet a further aspect of the present invention is shown in FIG. 4, showing one possible embodiment of the central reservoir for toothpaste or other substances suitable for dispensing. Here, the opening allows for input of a pet toothpaste or other appropriate substance into the reservoir, which is dispensed through perpendicular holes to the main cavity or cavities of the chew toy. Although in this particular embodiment the reservoir takes a cylindrical form, other embodiments might include one or more reservoirs of different shapes or locations.

[0030] Another possible embodiment of the present invention is shown in FIG. 3. Here, the central member comprises two inner surfaces, each defining separate cavities similar to the single cavity shown in FIG. 1. By providing a second cavity, a domestic pet can simultaneously engage not just the

forward and rear of the pet's teeth and gums simultaneously, but on the top and bottom of the pet's mouth as well.

What is claimed is:

1. A chew toy for domestic pet dental hygiene comprising:

A body comprising:

At least one outer surface;

At least one inner surface;

A first and a second end,

Wherein the inner surfaces define at least one cavity that is open on a first side and on the first end of the body;

A first plurality of scrubbing elements mounted on the first and second outer surfaces of the body;

A second plurality of scrubbing elements mounted on the inner surfaces of the body;

Wherein the scrubbing elements are configured to come into contact with a pet's front and back teeth when the pet bites the chew toy.

2. The chew toy of claim 1, further comprising:

One or more substantially flat projections from the second end of the body, said projections being perpendicular to the body;

Whereby the projections form a stable platform for the chew toy to stand upright on a surface when the second end is placed on the surface.

3. The chew toy of claim 2, further comprising:

A portion of the central member defining a reservoir having a first opening at the first end of the body, and a plurality of second openings giving access to the cavity or cavities.

4. The chew toy of claim 1, 2, or 3:

Wherein the second plurality of scrubbing elements are substantially smaller and more numerous than the first plurality of projections.

5. The chew toy of claim 1, 2, or 3:

Wherein the first plurality of scrubbing elements are substantially smaller and more numerous than the first plurality of projections.

6. The chew toy of claim 1, 2, or 3:

Wherein each plurality of scrubbing elements is comprised of more than one configuration of scrubbing element.

* * * * *