



3. I am an attorney for the Plaintiff Airigan Solutions, LLC (“Airigan” or “Plaintiff”) in the above-captioned case.

4. I make and submit this Affidavit in support of Plaintiff’s Application for an Order to Show Cause Why Default Judgment and Permanent Injunction Should Not be Entered Against Defaulting Defendants; the Defendants in default (hereinafter referred to as “Defaulting Defendants”) are indentified on Attachment “A” of the Clerk’s Certificate of Default.

5. I am informed and believe that none of the Defaulting Defendants are infants, mentally incompetent, or members of the military.

6. Attached hereto as **Exhibit 1** is a true and correct copy of the Amended Summons and Amended Complaint.

7. Attached hereto as **Exhibit 2** is a true and correct copy of the Certificate of Service for the Amended Summons and Amended Complaint.

8. Attached hereto as **Exhibit 3** is a true and correct copy of the Certificate of Default entered by the Clerk of the Court.

9. Attached as **Exhibit 4** is a an English language translation of an August 6, 2018 on-line article discussing Ference & Associates and this case. This article originally appeared in Chinese at <http://www.cifnews.com/article/36986> (last visited on November 29, 2018).

10. Attached hereto as **Exhibit 5** are copies of the Final Default Judgment and Permanent Injunction recently entered by this Court without a damages inquest in the following online counterfeiting cases: *Mattel, Inc. v. 86755, et al.*, 18-cv-8825 (JSR), DE No. 47 (S.D.N.Y. Dec. 17, 2018) (awarding statutory damages ranging from \$50-500,000 per defaulting defendant); *Moose Toys Pty Ltd. v. 963, et al.*, 18-cv-2187 (VEC), DE No. 209 (S.D.N.Y. Nov. 30, 2018) (awarding statutory damages of \$50-750,000 per defendant); and *Off-White LLC v.*

*A445995685, et al.*, 18-cv-2009 (LGS), DE No. 114 (S.D.N.Y. Sept. 27, 2018) (awarding statutory damages ranging from \$100,000 - \$2 million per defendant).

11. Attached as **Exhibit 6** hereto is a copy of *Luxottica Group S.P.A.*, 2017 WL 836228 (N.D. Ill. Mar. 2, 2017), where the Court awarded \$100,000 in statutory damages on summary judgment in an online counterfeiting case involving a small number of sales of counterfeit product where the defendant appeared and did not default, the defendant did not contest liability, and the defendant only contested the amount of damages owed to plaintiff.

### **I. Introduction and Background**

12. Defaulting Defendants are sophisticated sellers, each operating one or more commercial businesses using their respective user accounts. Defaulting Defendants were and/or are systematically directing and/or targeting their business activities at consumers in the U.S., including New York, through accounts with online marketplace platforms such as Alibaba.com, AliExpress.com, Amazon.com, DHgate.com, eBay.com, and Wish.com, as well as any and all as yet undiscovered accounts with additional online marketplace platforms held by or associated with Defendants, their respective officers, employees, agents, servants and all persons in active concert or participation with any of them (“User Accounts”). Through these User Accounts, Defaulting Defendants, their respective officers, employees, agents, servants and all persons in active concert of participation with any of them, operate storefronts to manufacture, import, export, advertise, market, promote, distribute, offer for sale and/or otherwise deal in products, including the Counterfeit Products,<sup>1</sup> which are held by or associated with Defaulting Defendants,

---

<sup>1</sup> “Counterfeit Products” are substandard products bearing or using Plaintiff’s registered trademark (*i.e.*, U.S. Trademark Reg. No. 5,142,630 for the wordmark “NEGG”) and/or that use packaging that bears and/or is used in connection with marks and/or trade dress (hereinafter referred to as the “NEGG Marks) that is confusing or substantially similar to Plaintiff’s authentic products sold using the NEGG Marks and/or that infringe at least Claim 1 of Plaintiff’s U.S. Patent No. 9,968,211 entitled “PERSONAL EGG PEELER” (hereinafter referred to as “the ‘211 patent”).

their respective officers, employees, agents, servants and all persons in active concert or participation with any of them (“Merchant Storefront(s)”).

13. As previously determined by this Court in entrance of the Temporary Restraining Order (as defined *infra*) and Preliminary Injunction Order (as defined *infra*), this Court has both subject matter jurisdiction and personal jurisdiction over the Defaulting Defendants. (See DE<sup>2</sup> 43 and 11).

## II. Procedural History

14. On July 6, 2018, Plaintiff filed this action, and moved *ex parte* against all of the Defendants identified on the **Schedule “A”** attached to the Complaint for the following: 1) a temporary restraining order; 2) an order restraining assets and Merchant Storefronts,<sup>3</sup> 3) an order to show cause why a preliminary injunction should not issue; 4) an order authorizing alternative service; and 5) an order authorizing expedited discovery against all of the Defendants (“the Application”) (DE 14).

15. On July 19, 2018, Plaintiff filed an Amended Complaint seeking the same relief against all of the Defendants identified on the **Amended Schedule “A”** attached to the Amended Complaint and an Amended Summons was issued that applied to all of the Defendants (DE 29).

16. On July 19, 2018, the Court entered an Order granting Plaintiff’s Application (the “TRO”) (DE 43).

17. In the TRO, the Court granted the Plaintiff’s request for an order authorizing alternative service by delivery of: PDF copies of the TRO, together with the Summons, Amended Complaint, and the related Papers and Orders via a link to a secure website (such as

---

<sup>2</sup> DE refers to “Docket Entry”.

<sup>3</sup> Where a defined term is referenced herein but not defined, it should be understood as it is defined in the Amended Complaint or Application.

Dropbox.com, NutStore.com, a large mail link created through RPost.com and via website publication through a specific page dedicated to this Lawsuit accessible through ferencelaw.com) where each Defendant is able to download PDF copies of the TRO together with the Amended Summons, Amended Complaint, related orders, and all papers filed in support of and related to Plaintiff's Application seeking the TRO. Service was to be made within five (5) days after the Financial Institutions and Third Party Service Providers complied with certain provisions of the TRO and in no event later than ten (10) days from the date of the TRO.

18. Plaintiff served all of the Defendants pursuant to the TRO (DE 50).

19. The TRO required the Defendants to attend an Order to Show Cause Hearing on Monday, July 30, 2018 at 1:00 p.m., to show cause why a preliminary injunction, pursuant to FRCP 65 (a) should not issue ("OSC").

20. By Order of July 27, 2018, the TRO was extended through August 7, 2018 and the OSC Hearing was re-scheduled to August 7, 2018 at 2:00 p.m.

21. On August 7, 2018 at 2:00 p.m., Plaintiff appeared for the OSC Hearing, however, only defendant powermup, spoken for by non-lawyer Dinan Wu, appeared. No Third Party Service Providers or Financial Institutions appeared.

22. Following the OSC Hearing, the Court entered a Preliminary Injunction Order against all Defendants extending the injunctive relief previously granted in the TRO though the pendency of this case ("PI Order")(DE 11).

23. Plaintiff subsequently served all of the Defendants with a copy of the PI Order in accordance with the terms of the PI Order (DE 50).

24. Throughout the case, Plaintiff filed various stipulations of dismissal as to certain Defendants.

25. On December 8, 2018, the court ordered that any order to show cause for default judgment as to any remaining Defendants be submitted in accordance with the Court's Individual Rules no later than February 11, 2019 (DE 79).

26. On February 4, 2019, Plaintiff filed a Request for Clerk's Certificate of Default with supporting Declaration, all in accordance with Fed. R. Civ. P. 55 (a), Local Civil Rule 55.1, and Rule 16.1 of the Southern District of New York Electronic Case Filing Rules & Instructions. See DE 89, 92.

27. On February 5, 2019, the Clerk of Court entered the default and issued a Clerk's Certificate of Default as to those remaining Defendants (i.e., Defaulting Defendants) identified in "Attachment A" of the Plaintiff's Request for Clerk's Certificate of Default. See DE 93.

28. As of the date of this Affidavit, Defaulting Defendants have neither answered with the Court, responded to the Complaint or otherwise formally appeared in the case.

### **III. Statement of Facts**

29. Although Plaintiffs properly effected service of the Amended Summons and Amended Complaint and all other documents supporting their Application on Defaulting Defendants in accordance with the TRO, Defaulting Defendants' failure to answer the Complaint or otherwise appear has deprived Plaintiffs of the ability to confirm whether or not Defaulting Defendants have ceased manufacturing, importing, exporting, advertising, marketing, promoting, distributing, displaying, offering for sale and/or selling Counterfeit Products.

30. Plaintiff and Plaintiff's counsel have learned that counterfeiters and infringers such as Defendants, cooperate, communicate, and coordinate their activities in full knowledge of the various lawsuits like Plaintiff's. Indeed, Plaintiff's counsel has confirmed this information during direct discussions with various Defendants and defense counsel. Plaintiff's counsel even

located an August 6, 2018 on-line article discussing Ference & Associates and this case. An English language translation of the article is attached hereto as **Exhibit 4**.<sup>4</sup> The article is remarkable in that appeared within 24 hours of the lawsuit being unsealed, thus confirming representations from other lawyers that information in the PACER docket is being monitored by Chinese sellers and their lawyers for seeking clients needing a defense from any new anti-counterfeiting lawsuits. This particular article purports to have been written by SellerDefense and invites questions from its readers. The summary “to sum up” appearing on page 8/14 is telling “[t]he shape of the NEGG egg stripper is quite special, using several points on the wall of the cup to impact the shell. The defendant’s publication is obviously infringing....”

31. Due to Defaulting Defendants’ defaults and failure to respond to or answer any discovery propounded by Plaintiff, Plaintiff was unable to obtain any information about the scope of the Defendants’ sales, profits, and costs relating to the Counterfeit Products, nor any other relevant discoverable issues.

32. To date, Plaintiff has only been able to review the discovery responses provided by Alibaba, Aliexpress, Amazon, eBay, and Wish. Due to software and database limitations, some of this information was quite limited or just plain missing. Moreover, DHGate does not even track the relevant information about sales so there is no meaningful discovery from the Defendants selling on DHGate.

33. Nevertheless, Plaintiff and Plaintiff’s counsel are well aware from personal experience that counterfeiters such as Defaulting Defendants, make it standard practice to diversify their selling across multiple e-commerce platforms to maximize their sales of the counterfeit products.

---

<sup>4</sup> (Originally appearing in Chinese at <http://www.cifnews.com/article/36986> (last visited on November 29, 2018)).

34. Accordingly, it is highly likely that Defaulting Defendants have used and continue to use other e-commerce platforms, ignoring the TRO and PI Order, to continue their counterfeiting and infringing activities, including offering for sale and selling Counterfeit Products.

35. It follows that the Defaulting Defendants' sales of Counterfeit Products are actually much higher than the numbers identified through Plaintiff's limited discovery in this case.

36. All of these limitations make it difficult, if not impossible, to calculate the full measure of Plaintiff's actual damages.

#### **IV. Plaintiff Seeks Statutory Damages**

37. The statutory damages sought by Plaintiff are based upon the analysis of the following factors: (1) the discovery responses, where available, showing the total number of sales of the Counterfeit Products made by the Defaulting Defendants' on the identified e-commerce platform; and (2) Defaulting Defendants infringing use of the NEGG Marks; and/or (3) Defaulting Defendants offer for sale of Counterfeit Products; and/or (4) Defaulting Defendants Offer for Sale of Infringing Products.

38. Plaintiff seeks an award of \$600,000 in statutory damages against Defaulting Defendant Sunfei (Def. No. 76), who is a marketplace seller on Amazon.com and whom Amazon informed me sold 618 units of Counterfeit Products; an award of \$300,000 in statutory damages against Defaulting Defendant yycj2010 (Def. No. 132), who is a seller on wish.com and whom Wish informed me sold 272 units of Counterfeit Products; and an award of \$100,000 in statutory damages against each of the remaining Defaulting Defendants.

39. The amount of statutory damages sought is within the norm awarded by this Court. *See Mattel, Inc. v. 86755, et al.*, 18-cv-8825 (JSR), DE No. 47 (S.D.N.Y. Dec. 17, 2018) (awarding statutory damages ranging from \$50-500,000 per defaulting defendant); *Moose Toys Pty Ltd. v. 963, et al.*, 18-cv-2187 (VEC), DE Nos. 209-257 (S.D.N.Y. Nov. 30, 2018) (awarding statutory damages ranging from \$50-750,000 per defendant); and *Off-White LLC v. A445995685, et al.*, 18-cv-2099 (LGS), DE No. 129 (S.D.N.Y. Nov. 16, 2018) (awarding statutory damages ranging from \$100,000 - \$2 million per defendant) (copies of each Default Judgment are attached as **Exhibit 5** hereto).

40. Plaintiff submits a minimum statutory damage award of \$100,000 is appropriate. Courts in the 7th Circuit generally award at least \$1,000,000 in statutory damages in a default judgment. Similarly, Courts in the 11th Circuit also generally award at least \$1,000,000 in statutory damages in a default judgment. *See, e.g., Eye Safety Sys., Inc. v. The Partnerships and Unincorporated Ass'ns. Identified in Schedule "A"*, Case No. 18-cv-00034 [D.E. 42] (N.D. Ill. Mar. 1, 2018) (awarding \$1 million in statutory damages per defendant); *Spin Master Ltd. v. The Unincorporated P'ships and Ass'ns. Identified in Schedule "A"*, Case No. 18-cv-01270 [D.E. 39] (N.D. Ill. Apr. 25, 2018) (same); *Levi Strauss & Co. v. The Unincorporated P'ships and Ass'ns. Identified in Schedule "A"*, Case No. 17-cv-04561 [D.E. 33] (N.D. Ill. Aug. 1, 2017) (same); *Yeti Coolers, LLC v. Taneil George*, Case No. 17-cv-62215 [D.E. 46] (S.D. Fl. Mar. 29, 2018) (same); *Mycoskie, LLC v. csmlong188*, Case No. 17-cv-60782 [D.E. 43] (S.D. Fl. Jul. 21, 2017) (same); *Fendi Adele, S.R.L. v. alma Hernandez*, Case No. 17-cv-62379 [D.E. 37] (S.D. Fl. Jan. 28, 2018) (same); *Burberry Ltd. v. The Partnerships and Unincorporated Ass'ns. Identified in Schedule "A"*, Case No. 17-cv-03255 [D.E. 37] (N.D. Ill. June 7, 2017) (same); *Louis Vutton Mallietier, S.A. v. Andrew Henry*, Case No. 17-cv-61034 [D.E. 40] (S.D. Fl. Aug. 22, 2017)

(same); *Cartier Int'l A.G. v. Anotoky*, Case No. 17-cv-60831 [D.E. 38] (S.D. Fl. Jul. 6, 2017) (same); *Lacoste Alligator S.A. v. 6666 store*, Case No. 17-cv-60046 [D.E. 49] (S.D. Fl. Jun. 28, 2017) (same); *Gucci Am., Inc. v. 8710 t-shirt shop*, Case No. 16-cv-63002 [D.E. 58] (S.D. Fl. Mar. 27, 2017) (same); and *Louis Vuitton Malletier, S.A. v. afste nxmu*, Case No. 17-cv-61819 [D.E. 39] (S.D. Fl. Dec. 12, 2017) (same). The basis for such an award of statutory damages is deterrence.

41. In a recent online counterfeiting case in the 7th Circuit where a defendant appeared and did not default, the defendant did not contest liability, and only contested the amount of damages owed to plaintiff, the District Court awarded \$100,000 in statutory damages on a summary judgment motion for eleven sales of counterfeit product. *Luxottica Group S.P.A.*, 2017 WL 836228, \*3 (N.D. Ill. Mar. 2, 2017) (“The Court thus finds it appropriate to impose a higher award to deter future infringement by Defendant and others because a counterfeiter must fear more than just having to turn over his ill-gotten gains to the rightful owners.”) (internal quotations omitted) (copy attached as **Exhibit 6** hereto). A minimum statutory damage award of \$100,000 on default judgment in the present case provides an appropriate level of deterrence given Defaulting Defendants’ admitted willful infringement. Anything less than \$100,000 will likely be viewed by Defaulting Defendants as just the cost of doing business.

42. No part of the judgment sought against the Defaulting Defendants has been paid to Plaintiff by any of the Defaulting Defendants.

#### **V. An Inquest into an Award of Damages is Unnecessary in this Case**

43. Courts have awarded damages post-default without an evidentiary hearing based upon affidavits submitted by the plaintiff. See *Mattel, Inc. v. 86755, et al.*, 18-cv-8825 (JSR), DE No. 47 (S.D.N.Y. Dec. 17, 2018); *Moose Toys Pty Ltd. v. 963, et al.*, 18-cv-2187 (VEC), DE No.

DE Nos. 209-257 (S.D.N.Y. Nov. 30, 2018); *Off-White LLC v. A445995685, et al.*, 18-cv-2099 (LGS), DE No. 129 (S.D.N.Y. Nov. 16, 2018); *Ideavillage Products Corp v. Dongguan Opete Yoga Wear Manufacturer Co., Ltd., et al.*, 17-cv-9099 (JMF), DE No. 34 (S.D.N.Y. March 2, 2018); *Ideavillage Products Corp. v. Chinafocus, et al.*, 17-cv-3894 (RA), DE No. 50 (S.D.N.Y. Feb. 8, 2018); *Rovio Entertainment Ltd and Rovio Animation Oy v. Angel Baby Factory dlb/a AngelbabyJ actory, et al.*, 17-cv-1840 (KPF), Dkt. No.65 (S.D.N.Y. Sept. 13, 2017); *Church & Dwight Co.*, 697 F. Supp. 2d at 295; *Rolex Watch U.S.A. Inc. v. Brown*, 2002 U.S. Dist. LEXIS 10054, \*54, (S.D.N.Y. June 5, 2002); *see also Tamarin v. Adams Caterers*, 13 F.3d 51, 54 (2d Cir. 1993).

I declare under the penalty of perjury laws of the United States of America that to the best of my knowledge the foregoing is true and correct.

Executed this 6th day of February, 2019, at Pittsburgh, Pennsylvania.

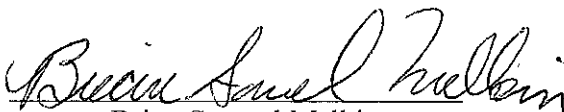
  
Brian Samuel Malkin

# **EXHIBIT 1**

UNITED STATES DISTRICT COURT  
for the  
Southern District of New York

AIRIGAN SOLUTIONS, LLC,

Plaintiff(s)

v.

YIWU LANHOME JEWELRY CO., LTD., et al.,

Defendant(s)

Civil Action No. 18-CV-6132 (GHW)

**AMENDED** SUMMONS IN A CIVIL ACTION

To: (Defendant's name and address)

SEE ATTACHED RIDER

A lawsuit has been filed against you.

Within 21 days after service of this summons on you (not counting the day you received it) — or 60 days if you are the United States or a United States agency, or an officer or employee of the United States described in Fed. R. Civ. P. 12 (a)(2) or (3) — you must serve on the plaintiff an answer to the attached complaint or a motion under Rule 12 of the Federal Rules of Civil Procedure. The answer or motion must be served on the plaintiff or plaintiff's attorney, whose name and address are:

Stanley D. Ference III  
Ference & Associates LLC  
409 Broad Street  
Pittsburgh, PA 15143

If you fail to respond, judgment by default will be entered against you for the relief demanded in the complaint. You also must file your answer or motion with the court.

RUBY J. KRAJICK  
CLERK OF COURT

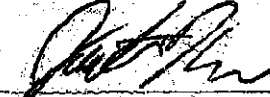

Signature of Clerk or Deputy Clerk

Date: JUL 19 2018

Civil Action No. 18-CV-6132 (GHW)

**PROOF OF SERVICE**

*(This section should not be filed with the court unless required by Fed. R. Civ. P. 4 (l))*

This summons for *(name of individual and title, if any)* \_\_\_\_\_  
was received by me on *(date)* \_\_\_\_\_.

I personally served the summons on the individual at *(place)* \_\_\_\_\_  
\_\_\_\_\_ on *(date)* \_\_\_\_\_ ; or

I left the summons at the individual's residence or usual place of abode with *(name)* \_\_\_\_\_  
\_\_\_\_\_, a person of suitable age and discretion who resides there,  
on *(date)* \_\_\_\_\_, and mailed a copy to the individual's last known address; or

I served the summons on *(name of individual)* \_\_\_\_\_, who is  
designated by law to accept service of process on behalf of *(name of organization)* \_\_\_\_\_  
\_\_\_\_\_ on *(date)* \_\_\_\_\_ ; or

I returned the summons unexecuted because \_\_\_\_\_ ; or

Other *(specify)*:

My fees are \$ \_\_\_\_\_ for travel and \$ \_\_\_\_\_ for services, for a total of \$ \_\_\_\_\_ 0.00 .

I declare under penalty of perjury that this information is true.

Date: \_\_\_\_\_

\_\_\_\_\_  
*Server's signature*

\_\_\_\_\_  
*Printed name and title*

\_\_\_\_\_  
*Server's address*

Additional information regarding attempted service, etc:

AMENDED SCHEDULE "A"

Def No.	Defendant by Seller ID	URL of Defendant's Merchant Storefront	ASIN/Prod ID/URL
1	Yiwu Lanhome Jewelry Co., Ltd.	<a href="https://lanhome.en.alibaba.com/">https://lanhome.en.alibaba.com/</a>	<a href="http://www.alibaba.com/product-detail/60770761889/40.htm">http://www.alibaba.com/product-detail/60770761889/40.htm</a>
2	Ningbo Mateyness Household Co., Ltd	<a href="https://mateyness.en.alibaba.com/">https://mateyness.en.alibaba.com/</a>	<a href="http://www.alibaba.com/product-detail/60757892976/Magic-Boiled-Egg-Peeler-Shell-Remover.html">http://www.alibaba.com/product-detail/60757892976/Magic-Boiled-Egg-Peeler-Shell-Remover.html</a>
3	Jiangshan Topme Import & Export Co., Ltd.	<a href="https://jstuojin.en.alibaba.com/">https://jstuojin.en.alibaba.com/</a>	<a href="http://www.alibaba.com/product-detail/60744710801/Boiled-Egg-Shell-Peeler-Peeling-Kitchen.html">http://www.alibaba.com/product-detail/60744710801/Boiled-Egg-Shell-Peeler-Peeling-Kitchen.html</a>
4	Yiwu Joyful Commodity Factory	<a href="https://wjoyful.en.alibaba.com/">https://wjoyful.en.alibaba.com/</a>	<a href="http://www.alibaba.com/product-detail/60755683587/Boiled-Egg-Stripper-Shell-Peeler-Peeling.html">http://www.alibaba.com/product-detail/60755683587/Boiled-Egg-Stripper-Shell-Peeler-Peeling.html</a>
5	Huizhou Kangning Industrial Co., Ltd	<a href="https://kangningid.en.alibaba.com/">https://kangningid.en.alibaba.com/</a>	<a href="http://www.alibaba.com/product-detail/60756633069/Boiled-Egg-Peeler.html">http://www.alibaba.com/product-detail/60756633069/Boiled-Egg-Peeler.html</a>
6	Ningbo Haishu Greenwell Commodity Industrial Co., Ltd.	<a href="https://nbgreenwell.en.alibaba.com/">https://nbgreenwell.en.alibaba.com/</a>	<a href="http://www.alibaba.com/product-detail/60756626122/Greenwell-hot-sale-egg-peeler-magic.html">http://www.alibaba.com/product-detail/60756626122/Greenwell-hot-sale-egg-peeler-magic.html</a>
7	Hefei Fengzhiheng Trade Co., Ltd	<a href="https://hfz.en.alibaba.com/">https://hfz.en.alibaba.com/</a>	<a href="http://www.alibaba.com/product-detail/60751634037/Hot-Selling-Egg-Shell-Peeler-Stripper.html">http://www.alibaba.com/product-detail/60751634037/Hot-Selling-Egg-Shell-Peeler-Stripper.html</a>
8	Ningbo Linkong International Trade Co	<a href="https://linkong.en.alibaba.com/">https://linkong.en.alibaba.com/</a>	<a href="https://www.alibaba.com/product-detail/Fun-Cooking-Gadgets-for-the-Family-60775409729.html">https://www.alibaba.com/product-detail/Fun-Cooking-Gadgets-for-the-Family-60775409729.html</a>
9	Yiwu Aliyout Commodity Ltd.	<a href="https://youmail.en.alibaba.com/">https://youmail.en.alibaba.com/</a>	<a href="https://www.alibaba.com/product-detail/Boiled-Egg-Shell-Peeler-Peeling-Kitchen-60752731931.html">https://www.alibaba.com/product-detail/Boiled-Egg-Shell-Peeler-Peeling-Kitchen-60752731931.html</a>
10	Ningbo Jiewei Kitchenware Co., Ltd.	<a href="https://hwkitchenware.en.alibaba.com/">https://hwkitchenware.en.alibaba.com/</a>	<a href="https://www.alibaba.com/product-detail/Customize-Egg-Peeler-Hard-Boiled-Egg-6075459548.html">https://www.alibaba.com/product-detail/Customize-Egg-Peeler-Hard-Boiled-Egg-6075459548.html</a>
11	Ningbo Shenghui Plastic Technology Co., Ltd.	<a href="https://tech2005.en.alibaba.com/">https://tech2005.en.alibaba.com</a>	<a href="http://www.alibaba.com/product-detail/60755683587/Boiled-Egg-Stripper-Shell-Peeler-Peeling.html">http://www.alibaba.com/product-detail/60755683587/Boiled-Egg-Stripper-Shell-Peeler-Peeling.html</a>
12	Shenzhen Vakind Technology Co., Ltd.	<a href="https://vakind.aliexpress.com/store/203288">https://vakind.aliexpress.com/store/203288</a>	<a href="http://www.aliexpress.com/item/Plastic-Egg-Shell-Peeler-Egg-Slicer-Cutter-Egg-Shell-Separator-Scissors-Peeling-Tool-Household-Kitchen-Cooking/32858171417.html">http://www.aliexpress.com/item/Plastic-Egg-Shell-Peeler-Egg-Slicer-Cutter-Egg-Shell-Separator-Scissors-Peeling-Tool-Household-Kitchen-Cooking/32858171417.html</a>
13	Pauprint Store	<a href="https://www.aliexpress.com/store/2675065">https://www.aliexpress.com/store/2675065</a>	<a href="http://www.aliexpress.com/item/2018-New-arrival-Egg-Shell-Peeler-Egg-Slicer-Cutter-Peeling-Tool-egg-Peeler-Kitchen-Tool-Home/32846925596.html">http://www.aliexpress.com/item/2018-New-arrival-Egg-Shell-Peeler-Egg-Slicer-Cutter-Peeling-Tool-egg-Peeler-Kitchen-Tool-Home/32846925596.html</a>
14	1st Kitchen Store	<a href="https://www.aliexpress.com/store/3450001">https://www.aliexpress.com/store/3450001</a>	<a href="http://www.aliexpress.com/item/IVYSHION-Egg-Shell-Peeler-Slicer-Remover-Dividers-Plastic-Egg-Scissors-Cutter-Handle-Egg-Tools-Drop-Shipping/32837952797.html">http://www.aliexpress.com/item/IVYSHION-Egg-Shell-Peeler-Slicer-Remover-Dividers-Plastic-Egg-Scissors-Cutter-Handle-Egg-Tools-Drop-Shipping/32837952797.html</a>
15	Good Lifestyle Store	<a href="https://www.aliexpress.com/store/2496049">https://www.aliexpress.com/store/2496049</a>	<a href="http://www.aliexpress.com/item/Egg-Shell-Peeler-Egg-Slicer-Cutter-Kitchen-Peeling-Tool-Egg-Peeler-for-Home-Kitchen-Accessories-Egg/32852766486.html">http://www.aliexpress.com/item/Egg-Shell-Peeler-Egg-Slicer-Cutter-Kitchen-Peeling-Tool-Egg-Peeler-for-Home-Kitchen-Accessories-Egg/32852766486.html</a>
16	Hinta Dropshipping Store	<a href="https://www.aliexpress.com/store/3155043">https://www.aliexpress.com/store/3155043</a>	<a href="http://www.aliexpress.com/item/Creative-Cooked-Egg-Peeler-Hard-Boiled-Egg-Shell-Peeler-Peeling-Kitchen-Tool/32860312736.html">http://www.aliexpress.com/item/Creative-Cooked-Egg-Peeler-Hard-Boiled-Egg-Shell-Peeler-Peeling-Kitchen-Tool/32860312736.html</a>
17	WholeWorld Store	<a href="https://www.aliexpress.com/store/1463728">https://www.aliexpress.com/store/1463728</a>	<a href="http://www.aliexpress.com/item/Cooked-Egg-Peeler-Hard-Boiled-Poached-Eggs-Shell-Peeler-Peeling-Kitchen-Tool-Home-egg-slicer/32858078185.html">http://www.aliexpress.com/item/Cooked-Egg-Peeler-Hard-Boiled-Poached-Eggs-Shell-Peeler-Peeling-Kitchen-Tool-Home-egg-slicer/32858078185.html</a>
18	StarStar Store	<a href="https://believe.aliexpress.com/store/7784019">https://believe.aliexpress.com/store/7784019</a>	<a href="http://www.aliexpress.com/item/Cooked-Egg-Peeler-Hard-Boiled-Poached-Eggs-Shell-Peeler-Peeling-Kitchen-Tool-Home-egg-slicer/32857902336.html">http://www.aliexpress.com/item/Cooked-Egg-Peeler-Hard-Boiled-Poached-Eggs-Shell-Peeler-Peeling-Kitchen-Tool-Home-egg-slicer/32857902336.html</a>
19	CCTX Store	<a href="https://www.aliexpress.com/store/3363024">https://www.aliexpress.com/store/3363024</a>	<a href="http://www.aliexpress.com/item/2018-Cooked-Egg-Peeler-Hard-Boiled-Poached-Egg-Shell-Peeler-Peeling-Kitchen-Tool-AP/32860921958.html">http://www.aliexpress.com/item/2018-Cooked-Egg-Peeler-Hard-Boiled-Poached-Egg-Shell-Peeler-Peeling-Kitchen-Tool-AP/32860921958.html</a>
20	MUQGEV Pets Store	<a href="https://www.aliexpress.com/store/3243081">https://www.aliexpress.com/store/3243081</a>	<a href="http://www.aliexpress.com/item/Cooked-Egg-Peeler-Hard-Boiled-Egg-Shell-Poached-Peeling-Kitchen-Tool-shape-for-egg-cutter/32857081274.html">http://www.aliexpress.com/item/Cooked-Egg-Peeler-Hard-Boiled-Egg-Shell-Poached-Peeling-Kitchen-Tool-shape-for-egg-cutter/32857081274.html</a>
21	KitchenMail Store	<a href="https://www.aliexpress.com/store/3402012">https://www.aliexpress.com/store/3402012</a>	<a href="http://www.aliexpress.com/item/New-Arrival-Egg-Shell-Peeler-Egg-Slicer-Cutter-Kitchen-Peeling-Tool-Egg-Peeler-For-Home-Kitchen/32854213530.html">http://www.aliexpress.com/item/New-Arrival-Egg-Shell-Peeler-Egg-Slicer-Cutter-Kitchen-Peeling-Tool-Egg-Peeler-For-Home-Kitchen/32854213530.html</a>
22	Me&My House China Textile Retail Store	<a href="https://www.aliexpress.com/store/2227092">https://www.aliexpress.com/store/2227092</a>	<a href="http://www.aliexpress.com/item/Peeler-Cooked-Egg-Peeler-Hard-Boiled-Poached-Egg-Shell-Peeler-Peeling-Kitchen-Tool-Drop-Shipping/32859923071.html">http://www.aliexpress.com/item/Peeler-Cooked-Egg-Peeler-Hard-Boiled-Poached-Egg-Shell-Peeler-Peeling-Kitchen-Tool-Drop-Shipping/32859923071.html</a>

AMENDED SCHEDULE "A"

Def No.	Defendant by Seller ID	URL of Defendant's Merchant Storefront	ASIN/Prod ID/URL
23	punkgirl store	<a href="https://www.aliexpress.com/store/1191437">https://www.aliexpress.com/store/1191437</a>	<a href="http://www.aliexpress.com/item/Egg-Peeler-Shell-Shell-Stripper-Peeling-Machine-Hard-Boiled-Convenient-Kitchen-Parings-Tool-TB-Sale/32882869849.html">http://www.aliexpress.com/item/Egg-Peeler-Shell-Shell-Stripper-Peeling-Machine-Hard-Boiled-Convenient-Kitchen-Parings-Tool-TB-Sale/32882869849.html</a>
24	Umaru's Houseware Store	<a href="https://www.aliexpress.com/store/2400091">https://www.aliexpress.com/store/2400091</a>	<a href="http://www.aliexpress.com/item/2018-New-Arrival-Egg-Shell-Peeler-Egg-Slicer-Cutter-Peeling-Tool-Hard-Boiled-Egg-Peeler-Kitchen/32872366542.html">http://www.aliexpress.com/item/2018-New-Arrival-Egg-Shell-Peeler-Egg-Slicer-Cutter-Peeling-Tool-Hard-Boiled-Egg-Peeler-Kitchen/32872366542.html</a>
25	Fantasy Garden & Life House Store	<a href="https://www.aliexpress.com/store/2802127">https://www.aliexpress.com/store/2802127</a>	<a href="http://www.aliexpress.com/item/Egg-Slicer-Kitchen-Gadgets/32866539668.html">http://www.aliexpress.com/item/Egg-Slicer-Kitchen-Gadgets/32866539668.html</a>
26	My House Store	<a href="https://www.aliexpress.com/store/2948247">https://www.aliexpress.com/store/2948247</a>	<a href="http://www.aliexpress.com/item/Egg-Tool-Cooked-Egg-Peeler-Hard-Kitchen-Tool-Boiled-Egg-Shell-Peeler-Peeling-Cooking-Tools-18MAR23/32859694732.html">http://www.aliexpress.com/item/Egg-Tool-Cooked-Egg-Peeler-Hard-Kitchen-Tool-Boiled-Egg-Shell-Peeler-Peeling-Cooking-Tools-18MAR23/32859694732.html</a>
27	Brunch Lifestyle Store	<a href="https://www.aliexpress.com/store/3239033">https://www.aliexpress.com/store/3239033</a>	<a href="http://www.aliexpress.com/item/2018-New-Arrival-Egg-Shell-Peeler-Plastic-Creative-Egg-Slicer-Cutter-Peeling-Tool-Egg-Peeler-Kitchen/32858119756.html">http://www.aliexpress.com/item/2018-New-Arrival-Egg-Shell-Peeler-Plastic-Creative-Egg-Slicer-Cutter-Peeling-Tool-Egg-Peeler-Kitchen/32858119756.html</a>
28	Transhome Dropshipping Kitchen Store	<a href="https://www.aliexpress.com/store/1713132">https://www.aliexpress.com/store/1713132</a>	<a href="http://www.aliexpress.com/item/1Pcs-Negg-Egg-Peeler-Scissors-Slicers-Dividers-Egg-Tools-Kitchen-Gadgets-Accessories-Drop-Shipping/32852209033.html">http://www.aliexpress.com/item/1Pcs-Negg-Egg-Peeler-Scissors-Slicers-Dividers-Egg-Tools-Kitchen-Gadgets-Accessories-Drop-Shipping/32852209033.html</a>
29	Believer Store	<a href="https://www.aliexpress.com/store/3676003">https://www.aliexpress.com/store/3676003</a>	<a href="http://www.aliexpress.com/item/1Pcs-Negg-Egg-Peeler-Scissors-Slicers-Dividers-Egg-Tools-Kitchen-Gadgets-Accessories-Drop-Shipping/32868876371.html">http://www.aliexpress.com/item/1Pcs-Negg-Egg-Peeler-Scissors-Slicers-Dividers-Egg-Tools-Kitchen-Gadgets-Accessories-Drop-Shipping/32868876371.html</a>
30	JOY HOME Mail	<a href="https://www.aliexpress.com/store/1997038">https://www.aliexpress.com/store/1997038</a>	<a href="http://www.aliexpress.com/item/Negg-Egg-Shell-Peeler-Kitchen-Tool-Home-Egg-Peeling-Tool/32856628180.html">http://www.aliexpress.com/item/Negg-Egg-Shell-Peeler-Kitchen-Tool-Home-Egg-Peeling-Tool/32856628180.html</a>
31	MIAONY Store	<a href="https://www.aliexpress.com/store/2885134">https://www.aliexpress.com/store/2885134</a>	<a href="http://www.aliexpress.com/item/1Pcs-Negg-Egg-Peeler-Scissors-Slicers-Dividers-Egg-Tools-Kitchen-Gadgets-Accessories-Drop-Shipping/32871422984.html">http://www.aliexpress.com/item/1Pcs-Negg-Egg-Peeler-Scissors-Slicers-Dividers-Egg-Tools-Kitchen-Gadgets-Accessories-Drop-Shipping/32871422984.html</a>
32	Dropship Hotsale Store	<a href="https://www.aliexpress.com/store/3637125">https://www.aliexpress.com/store/3637125</a>	<a href="http://www.aliexpress.com/item/Dropshipping-New-Clever-Negg-Boiled-Egg-Peeler-Magic-Egg-Shell-Dividers-Eggshell-Separator-Peeling-Kitchen-Gadget/32867913687.html">http://www.aliexpress.com/item/Dropshipping-New-Clever-Negg-Boiled-Egg-Peeler-Magic-Egg-Shell-Dividers-Eggshell-Separator-Peeling-Kitchen-Gadget/32867913687.html</a>
33	Hallelujah	<a href="https://www.aliexpress.com/store/326030">https://www.aliexpress.com/store/326030</a>	<a href="http://www.aliexpress.com/item/200Pcs-New-Arrival-Negg-Egg-Shell-Peeler-Kitchen-Tool-Home-Egg-Peeling-Tools-egg-scissors-/32863710267.html">http://www.aliexpress.com/item/200Pcs-New-Arrival-Negg-Egg-Shell-Peeler-Kitchen-Tool-Home-Egg-Peeling-Tools-egg-scissors-/32863710267.html</a>
34	Shanghai Jenny	<a href="https://www.aliexpress.com/store/1971468">https://www.aliexpress.com/store/1971468</a>	<a href="http://www.aliexpress.com/item/1Pcs-Negg-Egg-Peeler-Scissors-Slicers-Dividers-Egg-Tools-Kitchen-Gadgets-Accessories-Drop-Shipping/32871470424.html">http://www.aliexpress.com/item/1Pcs-Negg-Egg-Peeler-Scissors-Slicers-Dividers-Egg-Tools-Kitchen-Gadgets-Accessories-Drop-Shipping/32871470424.html</a>
35	FLYXF Store	<a href="https://www.aliexpress.com/store/4033097">https://www.aliexpress.com/store/4033097</a>	<a href="http://www.aliexpress.com/item/1Pcs-Negg-Egg-Peeler-Scissors-Slicers-Dividers-Egg-Tools-Kitchen-Gadgets-Accessories-Drop-Shipping/32883983270.html">http://www.aliexpress.com/item/1Pcs-Negg-Egg-Peeler-Scissors-Slicers-Dividers-Egg-Tools-Kitchen-Gadgets-Accessories-Drop-Shipping/32883983270.html</a>
36	Getyoursave	<a href="https://www.aliexpress.com/store/1491004">https://www.aliexpress.com/store/1491004</a>	<a href="http://www.aliexpress.com/item/1Pcs-Negg-Egg-Peeler-Scissors-Slicers-Dividers-Egg-Tools-Kitchen-Gadgets-Accessories-Drop-Shipping/32871454519.html">http://www.aliexpress.com/item/1Pcs-Negg-Egg-Peeler-Scissors-Slicers-Dividers-Egg-Tools-Kitchen-Gadgets-Accessories-Drop-Shipping/32871454519.html</a>
37	My SweetHome Store	<a href="https://www.aliexpress.com/store/1656297">https://www.aliexpress.com/store/1656297</a>	<a href="http://www.aliexpress.com/item/Egg-Shell-Peeler-Peeling-Tool-Boiled-Egg-Peeler-for-Kitchen-Egg-Boiled-Egg-Peeler/32871670399.html">http://www.aliexpress.com/item/Egg-Shell-Peeler-Peeling-Tool-Boiled-Egg-Peeler-for-Kitchen-Egg-Boiled-Egg-Peeler/32871670399.html</a>
38	Lucky Yune Store	<a href="https://www.aliexpress.com/store/3659035">https://www.aliexpress.com/store/3659035</a>	<a href="http://www.aliexpress.com/item/THE-NEGG-BOIL-ED-EGG-PEELER/32859587697.html">http://www.aliexpress.com/item/THE-NEGG-BOIL-ED-EGG-PEELER/32859587697.html</a>
39	Transhome Dropshipping Kitchen Store	<a href="https://www.aliexpress.com/store/1713132">https://www.aliexpress.com/store/1713132</a>	<a href="https://www.aliexpress.com/item/Transhome-10-Seconds-Egg-Stripper-Negg-Egg-Peeler-The-Goods-Egg-Kitchen-Dropshipping-Wholesalers-Bestsellers/32865657523.html">https://www.aliexpress.com/item/Transhome-10-Seconds-Egg-Stripper-Negg-Egg-Peeler-The-Goods-Egg-Kitchen-Dropshipping-Wholesalers-Bestsellers/32865657523.html</a>
40	Miss U Store	<a href="https://www.aliexpress.com/store/4086007">https://www.aliexpress.com/store/4086007</a>	<a href="https://www.aliexpress.com/item/10-Seconds-Egg-Stripper-Negg-Egg-Peeler-The-Goods-For-Kitchen-Dropshipping-Wholesalers-Bestsellers/1000005839719.html">https://www.aliexpress.com/item/10-Seconds-Egg-Stripper-Negg-Egg-Peeler-The-Goods-For-Kitchen-Dropshipping-Wholesalers-Bestsellers/1000005839719.html</a>
41	Honey Kitchen Store	<a href="https://www.aliexpress.com/store/2784165">https://www.aliexpress.com/store/2784165</a>	<a href="https://www.aliexpress.com/item/BOILED-EGG-PEELER-Egg-Shell-Peeler-Egg-Slicers-Slicers-Dividers-Cutter-Peeling-Tool-for-Home-Kitchen/32871051082.html">https://www.aliexpress.com/item/BOILED-EGG-PEELER-Egg-Shell-Peeler-Egg-Slicers-Slicers-Dividers-Cutter-Peeling-Tool-for-Home-Kitchen/32871051082.html</a>
42	Warm Harbor Store	<a href="https://www.aliexpress.com/store/3204007">https://www.aliexpress.com/store/3204007</a>	<a href="https://www.aliexpress.com/item/HOT-Egg-Shell-Peeler-Egg-Slicer-Cutter-Peeling-Tool-egg-Peeler-Kitchen-Tool-Home-Egg-Slicer/32860403350.html">https://www.aliexpress.com/item/HOT-Egg-Shell-Peeler-Egg-Slicer-Cutter-Peeling-Tool-egg-Peeler-Kitchen-Tool-Home-Egg-Slicer/32860403350.html</a>

AMENDED SCHEDULE "A"

Def No.	Defendant by Seller ID	URL of Defendant's Merchant Storefront	ASIN/Prod ID/URL
43	Leading your life Store	<a href="https://www.aliexpress.com/store/2937008">https://www.aliexpress.com/store/2937008</a>	<a href="https://www.aliexpress.com/item/Egg-Shell-Peeler-Egg-Slicer-Cutter-Peeling-Tool-Boiled-Egg-Peeler-Home-Egg-Slicer-Kitchen-Gadgets/32852704199.html">https://www.aliexpress.com/item/Egg-Shell-Peeler-Egg-Slicer-Cutter-Peeling-Tool-Boiled-Egg-Peeler-Home-Egg-Slicer-Kitchen-Gadgets/32852704199.html</a>
44	Practical Kitchen Store	<a href="https://www.aliexpress.com/store/3111053">https://www.aliexpress.com/store/3111053</a>	<a href="https://www.aliexpress.com/item/Egg-Shell-Peeler-Egg-Slicer-Cutter-Peeling-Tool-Boiled-Egg-Peeler-Home-Egg-Slicer-Kitchen-Gadgets/32872427379.html">https://www.aliexpress.com/item/Egg-Shell-Peeler-Egg-Slicer-Cutter-Peeling-Tool-Boiled-Egg-Peeler-Home-Egg-Slicer-Kitchen-Gadgets/32872427379.html</a>
45	KiIngPet Market Store	<a href="https://www.aliexpress.com/store/2881374">https://www.aliexpress.com/store/2881374</a>	<a href="https://www.aliexpress.com/item/Egg-Shell-Peeler-Egg-Slicer-Cutter-Peeling-Tool-Boiled-Egg-Peeler-Home-Egg-Slicer-Kitchen-Gadgets/328743271909.html">https://www.aliexpress.com/item/Egg-Shell-Peeler-Egg-Slicer-Cutter-Peeling-Tool-Boiled-Egg-Peeler-Home-Egg-Slicer-Kitchen-Gadgets/328743271909.html</a>
46	GeHe Store	<a href="https://gehe.aliexpress.com/store/1543548">https://gehe.aliexpress.com/store/1543548</a>	<a href="https://www.aliexpress.com/item/GOONBO-L-pc-Egg-Peeler-Plastic-Egg-Shell-Peeler-Egg-Slicer-Cutter-Peeling-Tool-Dropshipping/32868928327.html">https://www.aliexpress.com/item/GOONBO-L-pc-Egg-Peeler-Plastic-Egg-Shell-Peeler-Egg-Slicer-Cutter-Peeling-Tool-Dropshipping/32868928327.html</a>
47	Your assistant Store	<a href="https://www.aliexpress.com/store/3862025">https://www.aliexpress.com/store/3862025</a>	<a href="https://www.aliexpress.com/item/2018-New-arrival-Egg-Shell-Peeler-Egg-Slicer-Cutter-Peeling-Tool-egg-Peeler-Kitchen-Tool-Home/32875592879.html">https://www.aliexpress.com/item/2018-New-arrival-Egg-Shell-Peeler-Egg-Slicer-Cutter-Peeling-Tool-egg-Peeler-Kitchen-Tool-Home/32875592879.html</a>
48	WOWCC Dropshipping Store	<a href="https://www.aliexpress.com/store/1232637">https://www.aliexpress.com/store/1232637</a>	<a href="https://www.aliexpress.com/item/WOWCC-Egg-Shell-Peeler-Egg-Slicer-Cutter-Peeling-Tool-Egg-Peeler-Kitchen-Tool-Home-Egg-Slicer/32854360787.html">https://www.aliexpress.com/item/WOWCC-Egg-Shell-Peeler-Egg-Slicer-Cutter-Peeling-Tool-Egg-Peeler-Kitchen-Tool-Home-Egg-Slicer/32854360787.html</a>
49	AmyHome Store Store	<a href="https://www.aliexpress.com/store/2662193">https://www.aliexpress.com/store/2662193</a>	<a href="https://www.aliexpress.com/item/Plastic-Egg-Shell-Peeler-Egg-Slicer-Cutter-Egg-Shell-Separator-Scissors-Peeling-Tool-Household-Kitchen-Cooking/32876281402.html">https://www.aliexpress.com/item/Plastic-Egg-Shell-Peeler-Egg-Slicer-Cutter-Egg-Shell-Separator-Scissors-Peeling-Tool-Household-Kitchen-Cooking/32876281402.html</a>
50	Common Truth	<a href="https://tr.aliexpress.com/store/1380874">https://tr.aliexpress.com/store/1380874</a>	<a href="https://www.aliexpress.com/item/Household-Egg-Shell-Peeler-Egg-Slicer-Cutter-Egg-Shell-Separator-Scissors-Peeling-Tool-Plastic-Kitchen-Cooking/32858167464.html">https://www.aliexpress.com/item/Household-Egg-Shell-Peeler-Egg-Slicer-Cutter-Egg-Shell-Separator-Scissors-Peeling-Tool-Plastic-Kitchen-Cooking/32858167464.html</a>
51	VDHUK Store	<a href="https://tr.aliexpress.com/store/2970028">https://tr.aliexpress.com/store/2970028</a>	<a href="https://www.aliexpress.com/item/2018-New-Egg-Shell-Peeler-Kitchen-Egg-Cutter-Tool-Home-Egg-Slicer-Scissors-Dividers/32857183442.html">https://www.aliexpress.com/item/2018-New-Egg-Shell-Peeler-Kitchen-Egg-Cutter-Tool-Home-Egg-Slicer-Scissors-Dividers/32857183442.html</a>
52	Umar's Houseware Store	<a href="https://tr.aliexpress.com/store/2400091">https://tr.aliexpress.com/store/2400091</a>	<a href="https://www.aliexpress.com/item/2018-Hot-Sale-Egg-Shell-Peeler-Scissors-Remover-Dividers-Plastic-Egg-Slicer-Cutter-Handle-Egg-Tools/32871157682.html">https://www.aliexpress.com/item/2018-Hot-Sale-Egg-Shell-Peeler-Scissors-Remover-Dividers-Plastic-Egg-Slicer-Cutter-Handle-Egg-Tools/32871157682.html</a>
53	Shop1033157 Store	<a href="https://tr.aliexpress.com/store/1033157">https://tr.aliexpress.com/store/1033157</a>	<a href="https://www.aliexpress.com/item/Plastic-Egg-Shell-Peeler-Egg-Slicer-Cutter-Egg-Shell-Separator-Scissors-Peeling-Tool-Household-Kitchen-Cooking/32868766593.html">https://www.aliexpress.com/item/Plastic-Egg-Shell-Peeler-Egg-Slicer-Cutter-Egg-Shell-Separator-Scissors-Peeling-Tool-Household-Kitchen-Cooking/32868766593.html</a>
54	Best Home lifestyle	<a href="https://tr.aliexpress.com/store/2022020">https://tr.aliexpress.com/store/2022020</a>	<a href="https://www.aliexpress.com/item/Egg-Shell-Peeler-Plastic-Egg-Slicer-Egg-Shell-Separator-Hard-boiled-scissors-Peeling-Tool-Household-Kitchen/32882673944.html">https://www.aliexpress.com/item/Egg-Shell-Peeler-Plastic-Egg-Slicer-Egg-Shell-Separator-Hard-boiled-scissors-Peeling-Tool-Household-Kitchen/32882673944.html</a>
55	Loving Warm Home	<a href="https://tr.aliexpress.com/store/237015">https://tr.aliexpress.com/store/237015</a>	<a href="https://www.aliexpress.com/item/Egg-Shell-Peeler-Scissors-Remover-Dividers-Plastic-Egg-Slicer-Cutter-Handle-Eggs-Tools-Kitchen-Accessories-Cooking/32884904338.html">https://www.aliexpress.com/item/Egg-Shell-Peeler-Scissors-Remover-Dividers-Plastic-Egg-Slicer-Cutter-Handle-Eggs-Tools-Kitchen-Accessories-Cooking/32884904338.html</a>
56	TOPATY Store	<a href="https://tr.aliexpress.com/store/3174028">https://tr.aliexpress.com/store/3174028</a>	<a href="https://www.aliexpress.com/item/Plastic-Egg-Shell-Peeler-Egg-Slicer-Cutter-Egg-Shell-Separator-Scissors-Peeling-Tool-Household-Kitchen-Cooking/32876956216.html">https://www.aliexpress.com/item/Plastic-Egg-Shell-Peeler-Egg-Slicer-Cutter-Egg-Shell-Separator-Scissors-Peeling-Tool-Household-Kitchen-Cooking/32876956216.html</a>
57	Sunshine-store	<a href="https://tr.aliexpress.com/store/407893">https://tr.aliexpress.com/store/407893</a>	<a href="https://www.aliexpress.com/item/2018-New-Arrival-Egg-Shell-Peeler-Egg-Slicer-Cutter-Peeling-Egg-Separator-Tool-Kitchen-Accessories-Home/32864649696.html">https://www.aliexpress.com/item/2018-New-Arrival-Egg-Shell-Peeler-Egg-Slicer-Cutter-Peeling-Egg-Separator-Tool-Kitchen-Accessories-Home/32864649696.html</a>
58	Leading lifestyle store	<a href="https://tr.aliexpress.com/store/1359042">https://tr.aliexpress.com/store/1359042</a>	<a href="https://www.aliexpress.com/item/Egg-Shell-Peeler-Egg-Slicer-Cutter-Peeling-Tool-Boiled-Egg-Peeler-Home-Egg-Slicer-Kitchen-Gadgets/32873147813.html">https://www.aliexpress.com/item/Egg-Shell-Peeler-Egg-Slicer-Cutter-Peeling-Tool-Boiled-Egg-Peeler-Home-Egg-Slicer-Kitchen-Gadgets/32873147813.html</a>
59	Sweet dream family center98	<a href="https://tr.aliexpress.com/store/1752437">https://tr.aliexpress.com/store/1752437</a>	<a href="https://www.aliexpress.com/item/SDFC-Egg-Shell-Peeler-Egg-Slicer-Cutter-Peeling-Tool-egg-Peeler-Kitchen-Tool-Home-Egg-Slicer/32883000579.html">https://www.aliexpress.com/item/SDFC-Egg-Shell-Peeler-Egg-Slicer-Cutter-Peeling-Tool-egg-Peeler-Kitchen-Tool-Home-Egg-Slicer/32883000579.html</a>
60	Poodle XiaoCoCos Shop Store	<a href="https://he.aliexpress.com/store/3508046">https://he.aliexpress.com/store/3508046</a>	<a href="https://www.aliexpress.com/item/Egg-Shell-Peeler-Egg-Slicer-Cutter-Peeling-Tool-egg-Peeler-Kitchen-Tool-Home-Egg-Slicer-Stainless/32869262671.html">https://www.aliexpress.com/item/Egg-Shell-Peeler-Egg-Slicer-Cutter-Peeling-Tool-egg-Peeler-Kitchen-Tool-Home-Egg-Slicer-Stainless/32869262671.html</a>
61	Innovation Drinkware Store	<a href="https://www.aliexpress.com/store/3106052">https://www.aliexpress.com/store/3106052</a>	<a href="https://www.aliexpress.com/item/Egg-Shell-Peeler-Egg-Slicer-Cutter-Peeling-Tool-Boiled-Egg-Peeler-Home-Egg-Slicer-Kitchen-Gadgets/32869940511.html">https://www.aliexpress.com/item/Egg-Shell-Peeler-Egg-Slicer-Cutter-Peeling-Tool-Boiled-Egg-Peeler-Home-Egg-Slicer-Kitchen-Gadgets/32869940511.html</a>
62	CHINA REASARD Store	<a href="https://www.aliexpress.com/store/1440008">https://www.aliexpress.com/store/1440008</a>	<a href="https://www.aliexpress.com/item/2018-New-arrival-Egg-Shell-Peeler-Egg-Slicer-Cutter-Peeling-Tool-egg-Peeler-Kitchen-Tool-Home/32856970557.html">https://www.aliexpress.com/item/2018-New-arrival-Egg-Shell-Peeler-Egg-Slicer-Cutter-Peeling-Tool-egg-Peeler-Kitchen-Tool-Home/32856970557.html</a>
63	Enjoys Life Store	<a href="https://www.aliexpress.com/store/2947149">https://www.aliexpress.com/store/2947149</a>	<a href="https://www.aliexpress.com/item/Egg-Shell-Peeler-Egg-Slicer-Cutter-Peeling-Tool-Boiled-Egg-Peeler-Home-Egg-Slicer-Kitchen-Gadgets/32888789296.html">https://www.aliexpress.com/item/Egg-Shell-Peeler-Egg-Slicer-Cutter-Peeling-Tool-Boiled-Egg-Peeler-Home-Egg-Slicer-Kitchen-Gadgets/32888789296.html</a>
64	Noachic cafe Store	<a href="https://he.aliexpress.com/store/3178001">https://he.aliexpress.com/store/3178001</a>	<a href="https://www.aliexpress.com/item/NOCM-Egg-Shell-Peeler-Egg-Slicer-Cutter-Peeling-Tool-egg-Peeler-Kitchen-Tool-Home-Egg-Slicer/32862761602.html">https://www.aliexpress.com/item/NOCM-Egg-Shell-Peeler-Egg-Slicer-Cutter-Peeling-Tool-egg-Peeler-Kitchen-Tool-Home-Egg-Slicer/32862761602.html</a>
65	Aliaqingting Store	<a href="https://www.aliexpress.com/store/3650083">https://www.aliexpress.com/store/3650083</a>	<a href="https://www.aliexpress.com/item/Plastic-Egg-Shell-Peeler-Egg-Slicer-Cutter-Egg-Shell-Separator-Scissors-Peeling-Tool-Household-Kitchen-Cooking/32868123627.html">https://www.aliexpress.com/item/Plastic-Egg-Shell-Peeler-Egg-Slicer-Cutter-Egg-Shell-Separator-Scissors-Peeling-Tool-Household-Kitchen-Cooking/32868123627.html</a>

AMENDED SCHEDULE "A"

Def No.	Defendant by Seller ID	URL of Defendant's Merchant Storefront	ASIN/Prod ID/URL
66	Institute of Food	<a href="https://www.aliexpress.com/store/1865025">https://www.aliexpress.com/store/1865025</a>	<a href="https://www.aliexpress.com/item/Plastic-Manual-Eggs-Sheller-Eggs-Shell-Peeler-Eggs-Slicer-Cutter-Peeling-Tools-Eggs-Separator-Kitchen-Accessories/32885952968.html">https://www.aliexpress.com/item/Plastic-Manual-Eggs-Sheller-Eggs-Shell-Peeler-Eggs-Slicer-Cutter-Peeling-Tools-Eggs-Separator-Kitchen-Accessories/32885952968.html</a>
67	SKU Co., Ltd. Store	<a href="https://www.aliexpress.com/store/2344160">https://www.aliexpress.com/store/2344160</a>	<a href="https://www.aliexpress.com/item/Manual-Eggs-Sheller-Plastic-Eggs-Shell-Peeler-Eggs-Slicer-Cutter-Peeling-Tools-Eggs-Separator-Cooking-Tools/32885930768.html">https://www.aliexpress.com/item/Manual-Eggs-Sheller-Plastic-Eggs-Shell-Peeler-Eggs-Slicer-Cutter-Peeling-Tools-Eggs-Separator-Cooking-Tools/32885930768.html</a>
68	sweethome-sale	<a href="https://www.aliexpress.com/store/1656297">https://www.aliexpress.com/store/1656297</a>	<a href="https://www.aliexpress.com/item/Kitchen-Manual-Eggs-Sheller-Eggs-Shell-Peeler-Eggs-Slicer-Cutter-Peeling-Tools-Eggs-Separator-Accessories-Cooking/32885127704.html">https://www.aliexpress.com/item/Kitchen-Manual-Eggs-Sheller-Eggs-Shell-Peeler-Eggs-Slicer-Cutter-Peeling-Tools-Eggs-Separator-Accessories-Cooking/32885127704.html</a>
69	Fashion Store A8	<a href="https://www.aliexpress.com/store/1907984">https://www.aliexpress.com/store/1907984</a>	<a href="https://www.aliexpress.com/item/Instantly-Hard-Boiled-Egg-Shell-Peeler-Red-Black-Yellow-White/32875295957.html">https://www.aliexpress.com/item/Instantly-Hard-Boiled-Egg-Shell-Peeler-Red-Black-Yellow-White/32875295957.html</a>
70	Worldwide Droppshipping Store	<a href="https://www.aliexpress.com/store/3204074">https://www.aliexpress.com/store/3204074</a>	<a href="https://www.aliexpress.com/item/Egg-Shell-Peeler-Kitchen-Cooking-Tool-Plastic-Egg-Slicer-Cutter-Egg-Shell-Separator-Scissors-Peeling-Tool/32868346443.html">https://www.aliexpress.com/item/Egg-Shell-Peeler-Kitchen-Cooking-Tool-Plastic-Egg-Slicer-Cutter-Egg-Shell-Separator-Scissors-Peeling-Tool/32868346443.html</a>
71	Dolly's Arting Life	<a href="https://www.aliexpress.com/store/2348069">https://www.aliexpress.com/store/2348069</a>	<a href="https://www.aliexpress.com/item/Herd-Boiled-Egg-Shell-Peeler-Detachable-High-Quality-Egg-Shell-Peeler/32885187978.html">https://www.aliexpress.com/item/Herd-Boiled-Egg-Shell-Peeler-Detachable-High-Quality-Egg-Shell-Peeler/32885187978.html</a>
72	goodifer-Store	<a href="https://www.aliexpress.com/store/3359003">https://www.aliexpress.com/store/3359003</a>	<a href="https://www.aliexpress.com/item/PC-Manually-Egg-Sheller-Portable-Hard-Boiled-Egg-Shell-Separator-TV-Remove-Peeler-Magic-Amazing-Eggshell/32888161813.html">https://www.aliexpress.com/item/PC-Manually-Egg-Sheller-Portable-Hard-Boiled-Egg-Shell-Separator-TV-Remove-Peeler-Magic-Amazing-Eggshell/32888161813.html</a>
73	Go-Homing Store	<a href="https://www.aliexpress.com/store/2665213">https://www.aliexpress.com/store/2665213</a>	<a href="https://www.aliexpress.com/item/Cooked-Egg-Peeler-Hard-Hard-Boiled-Egg-Shell-Peeler-Peeling-Kitchen-Tool/32856829561.html">https://www.aliexpress.com/item/Cooked-Egg-Peeler-Hard-Hard-Boiled-Egg-Shell-Peeler-Peeling-Kitchen-Tool/32856829561.html</a>
74	YY Lucky Store	<a href="https://www.aliexpress.com/store/3883028">https://www.aliexpress.com/store/3883028</a>	<a href="https://www.aliexpress.com/item/Cooked-Egg-Sheller-Peeling-Eggshell-to-Cooked-Chicken-Eggshell-Tools/32862174791.html">https://www.aliexpress.com/item/Cooked-Egg-Sheller-Peeling-Eggshell-to-Cooked-Chicken-Eggshell-Tools/32862174791.html</a>
75	Unique Life Store	<a href="https://www.aliexpress.com/store/3567033">https://www.aliexpress.com/store/3567033</a>	<a href="https://www.aliexpress.com/item/Egg-Peeler-Cutter-Peeling-Tool-Kitchen-Tool-Egg-Shell-Separator/32880866071.html">https://www.aliexpress.com/item/Egg-Peeler-Cutter-Peeling-Tool-Kitchen-Tool-Egg-Shell-Separator/32880866071.html</a>
76	Sunfei	<a href="https://www.amazon.com/s?merchant=A1ATVBU0DXGZ">https://www.amazon.com/s?merchant=A1ATVBU0DXGZ</a>	B01NATZYU2, B01N255WK4
77	Some Interesting Store	<a href="https://www.amazon.com/s?merchant=A1V9USH5NV">https://www.amazon.com/s?merchant=A1V9USH5NV</a>	B07BF19WBZ
78	Zfitei	<a href="https://www.amazon.com/s?merchant=A3D0Y12PDY2CRF">https://www.amazon.com/s?merchant=A3D0Y12PDY2CRF</a>	B07CKPV969
79	Wishesport	<a href="https://www.amazon.com/s?merchant=A1EBS082D2H5KA">https://www.amazon.com/s?merchant=A1EBS082D2H5KA</a>	B07DBY9WHZ
80	SMYTSshop	<a href="https://www.amazon.com/SMYTSshop/b/ref=bl_dp_s_web_1727385011?ie=UTF8&amp;node=1727385011&amp;field-lbr_brands_browse-bin=SMYTSshop">https://www.amazon.com/SMYTSshop/b/ref=bl_dp_s_web_1727385011?ie=UTF8&amp;node=1727385011&amp;field-lbr_brands_browse-bin=SMYTSshop</a>	B07BHQK1TD
81	Fornernory	<a href="https://www.amazon.com/s?merchant=A245490AVST949">https://www.amazon.com/s?merchant=A245490AVST949</a>	B07CV9YSS8
82	Baoblaze	<a href="https://www.amazon.com/s?merchant=A3C8YK6W3F5JUNY">https://www.amazon.com/s?merchant=A3C8YK6W3F5JUNY</a>	B07D394VGF
83	Dolly Home	<a href="https://www.amazon.com/s?merchant=A1Z84CWF7LX7P">https://www.amazon.com/s?merchant=A1Z84CWF7LX7P</a>	B07D36YT2W
84	Brandon Trollpoe	<a href="https://www.amazon.com/s?merchant=A2UF2VWUJLRAZI">https://www.amazon.com/s?merchant=A2UF2VWUJLRAZI</a>	B07B2H3YQD, B07B2H6YB7
85	HolLeis	<a href="https://www.amazon.com/s?merchant=A2ZHB0FS74E6FF">https://www.amazon.com/s?merchant=A2ZHB0FS74E6FF</a>	B07BD5576N, B07BD554PR
86	TILary	<a href="https://www.amazon.com/s?merchant=A2W9E9DWUJ65XVL">https://www.amazon.com/s?merchant=A2W9E9DWUJ65XVL</a>	B07D7V5YVZ
87	HOMEFUL	<a href="https://www.amazon.com/Homeful/b/ref=bl_hsx_s_ki_web_15180153011?ie=UTF8&amp;node=15180153011&amp;field-lbr_brands_browse-bin=Homeful">https://www.amazon.com/Homeful/b/ref=bl_hsx_s_ki_web_15180153011?ie=UTF8&amp;node=15180153011&amp;field-lbr_brands_browse-bin=Homeful</a>	Any of the following ASIN numbers: ASIN: B07CGN969R, B07CVBB6G1, B07B2H6YB7, B07BYW9X1M, B07DFZHLST, B07CBNK5VB, B07CM1GFW1, B07B2H3YQD, B07BD5576N, B07D1251GY, B07D6MK5Y2, B07CWFQXX8, B07D5W33BW, B07CV9R266, B07D5YXMQM, B07CH5N88D, B07D5WDCBX, B07D1Q4VRD, B07C7VQ57W, B07DFZANJ4

AMENDED SCHEDULE "A"

Def No.	Defendant by Seller ID	URL of Defendant's Merchant Storefront	ASIN/Prod ID/URL
88	Labu Store	<a href="https://www.amazon.com/s?merchant=A1EFTQGAHWG4Z5">https://www.amazon.com/s?merchant=A1EFTQGAHWG4Z5</a>	Any of the following ASIN numbers: ASIN: B07CGN969R, B07CVBB6G1, B07B2H6YB7, B07BYWX91M, B07DFZHLST, B07CBNK5VB, B07CMIQFW1, B07B2H3YQD, B07BD5576N, B07D1251GY, B07D6MKS5V2, B07CWFQXX8, B07D5W33BW, B07CV9R266, B07D5VXMQM, B07CH5N88D, B07D5WDCBX, B07D1Q4VRD, B07C7VQ57W, B07DFZANJ4
89	ordon.piotr	<a href="https://www.amazon.com/s?merchant=A3H540W1B3SRHB">https://www.amazon.com/s?merchant=A3H540W1B3SRHB</a>	Any of the following ASIN numbers: ASIN: B07CGN969R, B07CVBB6G1, B07B2H6YB7, B07BYWX91M, B07DFZHLST, B07CBNK5VB, B07CMIQFW1, B07B2H3YQD, B07BD5576N, B07D1251GY, B07D6MKS5V2, B07CWFQXX8, B07D5W33BW, B07CV9R266, B07D5VXMQM, B07CH5N88D, B07D5WDCBX, B07D1Q4VRD, B07C7VQ57W, B07DFZANJ4
90	Brad2016	<a href="https://www.dhgate.com/store/20127493">https://www.dhgate.com/store/20127493</a>	<a href="https://www.dhgate.com/product/plastic-egg-shell-peeler-egg-slicer-cutter/422601483.html">https://www.dhgate.com/product/plastic-egg-shell-peeler-egg-slicer-cutter/422601483.html</a>
91	dhgate_factory01	<a href="https://www.dhgate.com/store/20644561">https://www.dhgate.com/store/20644561</a>	<a href="https://www.dhgate.com/store/product/2018-new-arrival-egg-shell-peeler-egg-slicer/411088513.html">https://www.dhgate.com/store/product/2018-new-arrival-egg-shell-peeler-egg-slicer/411088513.html</a>
92	dhgateop_merchant	<a href="https://www.dhgate.com/store/20748377">https://www.dhgate.com/store/20748377</a>	<a href="https://www.dhgate.com/store/product/plastic-egg-shell-peeler-egg-slicer-cutter/431089748.html">https://www.dhgate.com/store/product/plastic-egg-shell-peeler-egg-slicer-cutter/431089748.html</a>
93	greatseller	<a href="https://www.ebay.com/usr/greatseller">https://www.ebay.com/usr/greatseller</a>	<a href="https://www.ebay.com/fm/Hard-boiled-Egg-Peeler-Hard-boiled-Egg-Peeler-the-negg-Hard-boiled-Egg-Peeler/113077459319">https://www.ebay.com/fm/Hard-boiled-Egg-Peeler-Hard-boiled-Egg-Peeler-the-negg-Hard-boiled-Egg-Peeler/113077459319</a> <a href="https://www.ebay.com/fm/Hard-boiled-Egg-Peeler-Hard-boiled-the-negg-Egg-Peeler-Hard-boiled-Egg-Peeler/113079032121">https://www.ebay.com/fm/Hard-boiled-Egg-Peeler-Hard-boiled-the-negg-Egg-Peeler-Hard-boiled-Egg-Peeler/113079032121</a>
94	zouelbr_0	<a href="https://www.ebay.com/usr/zouelbr_0">https://www.ebay.com/usr/zouelbr_0</a>	<a href="https://www.ebay.com/fm/The-Negg-Hard-boiled-Egg-Peeler-Solutions-Egg-Peeler-Hard-Boiled-NIB/123191929460">https://www.ebay.com/fm/The-Negg-Hard-boiled-Egg-Peeler-Solutions-Egg-Peeler-Hard-Boiled-NIB/123191929460</a>
95	2017junmei	<a href="https://www.ebay.com/usr/2017junmei">https://www.ebay.com/usr/2017junmei</a>	<a href="https://www.ebay.com/fm/The-Negg-Hard-boiled-Egg-Peeler-Solutions-Egg-Peeler-Hard-Boiled-NIB/273304414722">https://www.ebay.com/fm/The-Negg-Hard-boiled-Egg-Peeler-Solutions-Egg-Peeler-Hard-Boiled-NIB/273304414722</a>
96	meiyodas0	<a href="https://www.ebay.com/usr/meiyodas0">https://www.ebay.com/usr/meiyodas0</a>	<a href="https://www.ebay.com/fm/The-Negg-Hard-boiled-Egg-Peeler-Solutions-Egg-Peeler-Hard-Boiled-NIB/255692916710">https://www.ebay.com/fm/The-Negg-Hard-boiled-Egg-Peeler-Solutions-Egg-Peeler-Hard-Boiled-NIB/255692916710</a>
97	best_4youu	<a href="https://www.ebay.com/usr/best_4youu">https://www.ebay.com/usr/best_4youu</a>	<a href="https://www.ebay.com/fm/The-Negg-Hard-boiled-Egg-Peeler-Solutions-Egg-Peeler-Hard-Boiled-NIB/253692944819">https://www.ebay.com/fm/The-Negg-Hard-boiled-Egg-Peeler-Solutions-Egg-Peeler-Hard-Boiled-NIB/253692944819</a>
98	trustworthy404	<a href="https://www.ebay.com/usr/trustworthy404">https://www.ebay.com/usr/trustworthy404</a>	<a href="https://www.ebay.com/fm/GIVEAWAY-PRIZE-The-Negg-Hard-boiled-Egg-Peeler-Solution-New-Easy-East-Pun/1231915685381">https://www.ebay.com/fm/GIVEAWAY-PRIZE-The-Negg-Hard-boiled-Egg-Peeler-Solution-New-Easy-East-Pun/1231915685381</a>
99	2015ilbruc	<a href="https://www.ebay.com/usr/2015ilbruc">https://www.ebay.com/usr/2015ilbruc</a>	<a href="https://www.ebay.com/fm/THE-NEGG-BOILED-EGG-PEELER-RED/253949759131">https://www.ebay.com/fm/THE-NEGG-BOILED-EGG-PEELER-RED/253949759131</a>
100	paciffantastic	<a href="https://www.ebay.com/usr/paciffantastic">https://www.ebay.com/usr/paciffantastic</a>	<a href="https://www.ebay.com/fm/THE-NEGG-BOILED-EGG-PEELER-YELLOW/192569771545">https://www.ebay.com/fm/THE-NEGG-BOILED-EGG-PEELER-YELLOW/192569771545</a>
101	silvishop15	<a href="https://www.ebay.com/usr/silvishop15">https://www.ebay.com/usr/silvishop15</a>	<a href="https://www.ebay.com/fm/THE-NEGG-BOILED-EGG-PEELER-RED-home-kitchen-tool/192847319593">https://www.ebay.com/fm/THE-NEGG-BOILED-EGG-PEELER-RED-home-kitchen-tool/192847319593</a>
102	xcocdzianzi	<a href="https://www.ebay.com/usr/xcocdzianzi">https://www.ebay.com/usr/xcocdzianzi</a>	<a href="https://www.ebay.com/fm/Egg-Peeler-Solutions-Egg-Peeler-Hard-Boiled-NIB-The-Negg-Hard-Boiled-Multicolor/323511377257">https://www.ebay.com/fm/Egg-Peeler-Solutions-Egg-Peeler-Hard-Boiled-NIB-The-Negg-Hard-Boiled-Multicolor/323511377257</a>
103	nalimat	<a href="https://www.ebay.com/usr/nalimat">https://www.ebay.com/usr/nalimat</a>	<a href="https://www.ebay.com/fm/Egg-Shell-Peeler-Egg-Slicer-Cutter-Peeling-Tool-egg-Peeler-Kitchen-Tool-Home/232804767876">https://www.ebay.com/fm/Egg-Shell-Peeler-Egg-Slicer-Cutter-Peeling-Tool-egg-Peeler-Kitchen-Tool-Home/232804767876</a>

AMENDED SCHEDULE "A"

Def No.	Defendant by Seller ID	URL of Defendant's Merchant Storefront	ASIN/Prod ID/URL
104	kctsimplesale	<a href="https://www.ebay.com/usr/kctsimplesale">https://www.ebay.com/usr/kctsimplesale</a>	<a href="https://www.ebay.com/itm/New-Egg-Shell-Peeler-Egg-Slicer-RED-Peeling-Tool-egg-Peeler-Kitchen-Tool-Egg-Z69774467518">https://www.ebay.com/itm/New-Egg-Shell-Peeler-Egg-Slicer-RED-Peeling-Tool-egg-Peeler-Kitchen-Tool-Egg-Z69774467518</a>
105	hanoune_9816	<a href="https://www.ebay.com/usr/hanoune_9816">https://www.ebay.com/usr/hanoune_9816</a>	<a href="https://www.ebay.com/itm/New-Egg-Shell-Peeler-Egg-Slicer-Cutter-Peeling-Tool-egg-Peeler-Kitchen-Tool-Egg-192551929794">https://www.ebay.com/itm/New-Egg-Shell-Peeler-Egg-Slicer-Cutter-Peeling-Tool-egg-Peeler-Kitchen-Tool-Egg-192551929794</a>
106	arnat-gadgets-shop	<a href="https://www.ebay.com/usr/arnat-gadgets-shop">https://www.ebay.com/usr/arnat-gadgets-shop</a>	<a href="https://www.ebay.com/itm/Egg-Shell-Peeler-Egg-Slicer-Cutter-Peeling-Tool-egg-Peeler-Kitchen-Tool-Home/143022421287">https://www.ebay.com/itm/Egg-Shell-Peeler-Egg-Slicer-Cutter-Peeling-Tool-egg-Peeler-Kitchen-Tool-Home/143022421287</a>
107	ultimate1seller	<a href="https://www.ebay.com/usr/ultimate1seller">https://www.ebay.com/usr/ultimate1seller</a>	<a href="https://www.ebay.com/itm/New-Egg-Shell-Peeler-Egg-Slicer-Cutter-Peeling-Tool-egg-Peeler-Kitchen-Tool-Home/253729863381">https://www.ebay.com/itm/New-Egg-Shell-Peeler-Egg-Slicer-Cutter-Peeling-Tool-egg-Peeler-Kitchen-Tool-Home/253729863381</a>
108	yihangjc	<a href="https://www.ebay.com/usr/yihangjc">https://www.ebay.com/usr/yihangjc</a>	<a href="https://www.ebay.com/itm/The-Negg-Red-Black-White-Yellow-By-Airgan-Solutions-Egg-Peeler-Hard-Boiled-NIB/792628390898">https://www.ebay.com/itm/The-Negg-Red-Black-White-Yellow-By-Airgan-Solutions-Egg-Peeler-Hard-Boiled-NIB/792628390898</a>
109	eqfgfs	<a href="https://www.ebay.com/usr/eqfgfs">https://www.ebay.com/usr/eqfgfs</a>	<a href="https://www.ebay.com/itm/The-Negg-Hard-boiled-Egg-Peeler-Solutions-Egg-Peeler-Hard-Boiled-NIB/323321008780">https://www.ebay.com/itm/The-Negg-Hard-boiled-Egg-Peeler-Solutions-Egg-Peeler-Hard-Boiled-NIB/323321008780</a>
110	qwvdss	<a href="https://www.ebay.com/usr/qwvdss">https://www.ebay.com/usr/qwvdss</a>	<a href="https://www.ebay.com/itm/The-Negg-Hard-boiled-Egg-Peeler-Solutions-Egg-Peeler-Hard-Boiled-NIB/223039638674">https://www.ebay.com/itm/The-Negg-Hard-boiled-Egg-Peeler-Solutions-Egg-Peeler-Hard-Boiled-NIB/223039638674</a>
111	RIENGCHU	<a href="https://www.wish.com/merchant/5555dc3688be01b1296deca8e">https://www.wish.com/merchant/5555dc3688be01b1296deca8e</a>	<a href="https://www.wish.com/c/5aa397e62ef5517a1135fd">https://www.wish.com/c/5aa397e62ef5517a1135fd</a>
112	fengdingluohua	<a href="https://www.wish.com/merchant/58c8a083fa214571564c0098">https://www.wish.com/merchant/58c8a083fa214571564c0098</a>	<a href="https://www.wish.com/c/5a61a96b5708591274c5f9ad">https://www.wish.com/c/5a61a96b5708591274c5f9ad</a>
113	Coolyard	<a href="https://www.wish.com/merchant/59994e6b18d92101ef67d0dc">https://www.wish.com/merchant/59994e6b18d92101ef67d0dc</a>	<a href="https://www.wish.com/c/5a6b9fb8304257110e780ab">https://www.wish.com/c/5a6b9fb8304257110e780ab</a>
114	vakind2018	<a href="https://www.wish.com/merchant/59745097960464b6525f8fb">https://www.wish.com/merchant/59745097960464b6525f8fb</a>	<a href="https://www.wish.com/c/5b0cb59bc13755386a171543">https://www.wish.com/c/5b0cb59bc13755386a171543</a>
115	gudaobigworld	<a href="https://www.wish.com/merchant/58356ca227a1ab489af66fc">https://www.wish.com/merchant/58356ca227a1ab489af66fc</a>	<a href="https://www.wish.com/c/5a9931c21a8c2172841a2dfb">https://www.wish.com/c/5a9931c21a8c2172841a2dfb</a>
116	Mygiftshop	<a href="https://www.wish.com/merchant/5800b551746f2b55fd23f319">https://www.wish.com/merchant/5800b551746f2b55fd23f319</a>	<a href="https://www.wish.com/c/5a9cee05c7e80b0e75986cae">https://www.wish.com/c/5a9cee05c7e80b0e75986cae</a>
117	PowerMup	<a href="https://www.wish.com/merchant/59e78e20a332a5f879a68a0">https://www.wish.com/merchant/59e78e20a332a5f879a68a0</a>	<a href="https://www.wish.com/c/5aa967047c74933704fe806e">https://www.wish.com/c/5aa967047c74933704fe806e</a>
118	WildLion	<a href="https://www.wish.com/merchant/5a9e695b9505f19fc287c15">https://www.wish.com/merchant/5a9e695b9505f19fc287c15</a>	<a href="https://www.wish.com/c/5a3ca738c7e80b0e148859c7">https://www.wish.com/c/5a3ca738c7e80b0e148859c7</a>
119	youneedit	<a href="https://www.wish.com/merchant/5a167cb20c47b72891e98d54">https://www.wish.com/merchant/5a167cb20c47b72891e98d54</a>	<a href="https://www.wish.com/c/5a0c602fbd784c509668a332">https://www.wish.com/c/5a0c602fbd784c509668a332</a>
120	AdventureHelper	<a href="https://www.wish.com/merchant/5a99e1b57b125ab05e5addc06">https://www.wish.com/merchant/5a99e1b57b125ab05e5addc06</a>	<a href="https://www.wish.com/c/5af29747ce2c701316f657fc">https://www.wish.com/c/5af29747ce2c701316f657fc</a>
121	Liliang Da Technology	<a href="https://www.wish.com/merchant/56f88ae885558c2865934047">https://www.wish.com/merchant/56f88ae885558c2865934047</a>	<a href="https://www.wish.com/c/5a3cb453e3eb0879b4a66037">https://www.wish.com/c/5a3cb453e3eb0879b4a66037</a>
122	Unbeatable.com	<a href="https://www.wish.com/merchant/8491f82e">https://www.wish.com/merchant/8491f82e</a>	<a href="https://www.wish.com/c/5ab9e46e31ab08a02cd2f853">https://www.wish.com/c/5ab9e46e31ab08a02cd2f853</a>
123	treebackwe18	<a href="https://www.wish.com/merchant/5954a16549b15a627e4e7fb">https://www.wish.com/merchant/5954a16549b15a627e4e7fb</a>	<a href="https://www.wish.com/c/5aaaf1ba7d4840c3ebca1060">https://www.wish.com/c/5aaaf1ba7d4840c3ebca1060</a>
124	Fashion-Master	<a href="https://www.wish.com/merchant/54815a6740b37805abe61480">https://www.wish.com/merchant/54815a6740b37805abe61480</a>	<a href="https://www.wish.com/c/5ab3524147e0e73f26e9dbd4">https://www.wish.com/c/5ab3524147e0e73f26e9dbd4</a>
125	Rogerww	<a href="https://www.wish.com/merchant/577cd7d7bf215340c1f126da">https://www.wish.com/merchant/577cd7d7bf215340c1f126da</a>	<a href="https://www.wish.com/c/5a66f697a7d48446e48e20d">https://www.wish.com/c/5a66f697a7d48446e48e20d</a>
126	PowerMup	<a href="https://www.wish.com/merchant/59e78e20a332a5f879a68a0">https://www.wish.com/merchant/59e78e20a332a5f879a68a0</a>	<a href="https://www.wish.com/c/5aa28448bd784c76336f6d099">https://www.wish.com/c/5aa28448bd784c76336f6d099</a>
127	coververse	<a href="https://www.wish.com/merchant/53426c2b736046712eed43120">https://www.wish.com/merchant/53426c2b736046712eed43120</a>	<a href="https://www.wish.com/c/5aab425c1a8c212fb379a01e">https://www.wish.com/c/5aab425c1a8c212fb379a01e</a>
128	Embroidered shop	<a href="https://www.wish.com/merchant/587363c69ed2cb4d484b189">https://www.wish.com/merchant/587363c69ed2cb4d484b189</a>	<a href="https://www.wish.com/c/5ab88dae7dcb0652ef1fa02c">https://www.wish.com/c/5ab88dae7dcb0652ef1fa02c</a>

AMENDED SCHEDULE "A"

Def No.	Defendant by Seller ID	URL of Defendant's Merchant Storefront	ASIN/Prod ID/URL
129	moralkop	<a href="https://www.wish.com/merchant/5568e4b92e9be122fb46cc4">https://www.wish.com/merchant/5568e4b92e9be122fb46cc4</a>	<a href="https://www.wish.com/c/5aab66725e2ae1746445b4b4">https://www.wish.com/c/5aab66725e2ae1746445b4b4</a>
130	jingpinghuadian	<a href="https://www.wish.com/merchant/5ac9c4952fbba42f95f8471">https://www.wish.com/merchant/5ac9c4952fbba42f95f8471</a>	<a href="https://www.wish.com/c/5ad25c8ea69e663716cae53a">https://www.wish.com/c/5ad25c8ea69e663716cae53a</a>
131	thamarvei	<a href="https://www.wish.com/merchant/5829940de18c0f36409b2007">https://www.wish.com/merchant/5829940de18c0f36409b2007</a>	<a href="https://www.wish.com/c/5a9a87a617c7a97974914e7c">https://www.wish.com/c/5a9a87a617c7a97974914e7c</a>
132	yych2010	<a href="https://www.wish.com/merchant/58368df4810891489643058e">https://www.wish.com/merchant/58368df4810891489643058e</a>	<a href="https://www.wish.com/c/5a6aeaa9579f07083c6494">https://www.wish.com/c/5a6aeaa9579f07083c6494</a>
133	guocangmaoyi	<a href="https://www.wish.com/merchant/5affb180f853f45f5247a0a8">https://www.wish.com/merchant/5affb180f853f45f5247a0a8</a>	<a href="https://www.wish.com/c/5b24766553d6cd0768666d137">https://www.wish.com/c/5b24766553d6cd0768666d137</a>
134	newyantage	<a href="https://www.wish.com/merchant/59c228e7235f34421d69f5ac">https://www.wish.com/merchant/59c228e7235f34421d69f5ac</a>	<a href="https://www.wish.com/c/5a1674fa64f627ca3511ff">https://www.wish.com/c/5a1674fa64f627ca3511ff</a>
135	Hippie's store	<a href="https://www.wish.com/merchant/5866083baf29f44d40f5206a">https://www.wish.com/merchant/5866083baf29f44d40f5206a</a>	<a href="https://www.wish.com/c/5ab078801b3a821178b5d4ee">https://www.wish.com/c/5ab078801b3a821178b5d4ee</a>

**FERENCE & ASSOCIATES LLC**

Stanley D. Ference III (SF1086)  
409 Broad Street  
Pittsburgh, Pennsylvania 15143  
Telephone: (412) 741-8400  
Facsimile: (412) 741-9292

Attorneys for Plaintiff

UNITED STATES DISTRICT COURT  
SOUTHERN DISTRICT OF NEW YORK

-----X

AIRIGAN SOLUTIONS, LLC,

Plaintiff,

v.

YIWU LANHOME JEWELRY CO., LTD.,  
NINGBO MATEYNESS HOUSEHOLD CO.,  
LTD., JIANGSHAN TOPME IMPORT &  
EXPORT CO., LTD., YIWU JOYFUL  
COMMODITY FACTORY, HUIZHOU  
KANGNING INDUSTRIAL CO., LTD.,  
NINGBO HAISHU GREENWELL  
COMMODITY INDUSTRIAL CO., LTD.,  
HEFEI FENGZHISHENG TRADE CO., LTD.,  
NINGBO LIMKONG INTERNATIONAL  
TRADE CO, YIWU ALIYOU COMMODITY  
LTD., NINGBO JIEWEI KITCHENWARE CO.,  
LTD., NINGBO SHENGHUI PLASTIC  
TECHNOLOGY CO., LTD., and THE OTHER  
INDIVIDUALS, PARTNERSHIPS AND  
UNINCORPORATED ASSOCIATIONS  
IDENTIFIED ON AMENDED SCHEDULE "A",

Defendants.

-----X

Civil Action No.

18-CV-6132 (GHW)

Jury Trial Requested

**FILED UNDER SEAL**

**AMENDED COMPLAINT FOR DAMAGES AND INJUNCTIVE RELIEF**

Plaintiff, Airigan Solutions, LLC, hereby sues those entities named in the caption and the other Individuals, Partnerships and Unincorporated Associations which are set forth on Amended Schedule "A" hereto (collectively "Defendants"). Defendants are (i) promoting, selling, offering for sale and distributing goods bearing and/or using counterfeits and confusingly similar imitations of Plaintiff's registered trademark and its trade dress and (ii) promoting, selling, offering for sale and distributing goods infringing Plaintiff's patent within this district through various fully interactive commercial Internet websites and Internet based e-commerce stores using the seller identities and store URLs set forth on **Amended Schedule "A"** hereto (collectively, the "Seller IDs"). In support of its claims, Plaintiff alleges as follows:

**JURISDICTION AND VENUE**

1. This is an action for federal trademark counterfeiting and infringement; false designation of origin, passing off, and unfair competition; common law unfair competition; and common law trademark infringement pursuant to 15 U.S.C. §§ 1114, 1116, 1125(a), and 1125(d), and patent infringement pursuant to 35 U.S.C. § 271 and The All Writs Act, 28 U.S.C. § 1651(a). Accordingly, this Court has subject matter jurisdiction over this action pursuant to 15 U.S.C. § 1121 and 28 U.S.C. §§ 1331 and 1338. This Court has supplemental jurisdiction pursuant to 28 U.S.C. § 1367 over Plaintiff's state law claims because those claims are so related to the federal claims that they form part of the same case or controversy.

2. Personal jurisdiction exists over Defendants in this judicial district pursuant to N.Y.C.P.L.R. § 302(a)(1) and N.Y.C.P.L.R. § 302(a)(3), or in the alternative, Federal Rule of Civil Procedure 4(k), because, upon information and belief, Defendants regularly conduct, transact and/or solicit business in New York and in this judicial district, and/or derive substantial revenue from their business transactions in New York and in this judicial district and/or

otherwise avail themselves of the privileges and protections of the laws of the State of New York such that this Court's assertion of jurisdiction over Defendants does not offend traditional notions of fair play and due process, and/or Defendants' illegal counterfeiting and infringing actions caused injury to Plaintiff in New York and in this judicial district such that Defendants should reasonably expect such actions to have consequences in New York and in this judicial district, for example:

a. Upon information and belief, Defendants were and/or are systematically directing and/or targeting their business activities at consumers in the U.S., including New York, through accounts with online marketplace platforms such as Alibaba.com, AliExpress.com Amazon.com, DHgate.com, eBay.com, and Wish.com, as well as any and all as yet undiscovered accounts with additional online marketplace platforms held by or associated with Defendants, their respective officers, employees, agents, servants and all persons in active concert or participation with any of them ("User Accounts"), through which consumers in the U.S., including New York, can view the one or more of Defendants' merchant storefronts that each Defendant operates, uses to communicate with Defendants regarding their listings for Counterfeit Products and to place orders for, receive invoices for and purchase Counterfeit Products for delivery in the U.S., including New York, as a means for establishing regular business with the U.S., including New York.

b. Upon information and belief, certain Defendants are sophisticated sellers, each operating one or more commercial businesses using their respective User Accounts through which Defendants, their respective officers, employees, agents, servants and all persons in active concert of participation with any of them, operate storefronts to manufacture, import, export, advertise, market, promote, distribute, offer for sale and/or otherwise deal in

products, including the Counterfeit Products, which are held by or associated with Defendants, their respective officers, employees, agents, servants and all persons in active concert or participation with any of them (“Merchant Storefront(s)”) in wholesale quantities at significantly below-market prices to consumers worldwide, including to those in the U.S., and specifically New York.

c. Upon information and belief, a majority of Defendants’ Merchant Storefronts reflect multiple sales to consumers all over the world, including repeat sales to consumers in the U.S.

d. Upon information and belief, all Defendants accept payment in U.S. Dollars and offer shipping to the U.S., including to New York and specifically to the New York Address (as defined *infra*).

e. Upon information and belief, Defendants have transacted business with consumers located in the U.S., including New York, for the sale and shipment of Counterfeit Products.

f. Upon information and belief, Defendants are aware of Plaintiff, its NEGG product, and are aware that their illegal counterfeiting and infringing actions alleged herein are likely to cause injury to Plaintiff in the U.S., in New York and in this judicial district specifically, as Plaintiff conducts substantial business in New York.

3. Venue is proper, *inter alia*, pursuant to 28 U.S.C. § 1391 and 28 U.S.C. § 1400(b) because, for example:

a. Upon information and belief, Defendants conduct, transact, and/or solicit business in this judicial district.

b. Upon information and belief, Defendants or their agent(s) may be found in this district because personal jurisdiction is proper in this district.

c. Upon information and belief, this is a judicial district in which a substantial part of the events or omissions giving rise to the infringement claims occurred, or a substantial part of the property that is the subject of the action is situated.

d. Defendants not resident in the United States may be sued in this judicial district because personal jurisdiction is proper in this district.

#### **THE PARTIES**

4. Plaintiff, Airigan Solutions, LLC (“Airigan Solutions”) is a limited liability company organized and existing under the laws of the State of Connecticut, having its principal place of business at 107 John Street, Suite 1-C, Southport, Connecticut 06890.

5. Upon information and belief, the Defendants are individuals and/or business entities of unknown makeup, each of whom, upon information and belief, either reside or operate in foreign jurisdictions, or redistribute products from the same or similar sources in those locations. Defendants have the capacity to be sued pursuant to Federal Rule of Civil Procedure 17(b). Defendants target their business activities toward consumers throughout the United States, including within this district, and conduct pervasive business through the operation of, at least, the fully interactive commercial Internet websites and Internet based online marketplace websites Alibaba.com, AliExpress.com, Amazon.com, DHgate.com, eBay.com, and/or Wish.com, via the e-commerce stores existing under the Seller IDs.

6. Upon information and belief, the Defendants that sell through Alibaba.com are the source of the Counterfeit Products that are then sold and/or distributed in the United States

including this judicial district, on AliExpress.com, Amazon.com, DHgate.com, eBay.com, and/or Wish.com, through the established distribution channels of the other Defendants identified on **Amended Schedule "A"**. Upon information and belief, Alibaba.com is the only online marketplace which provides a physical address listing for a Merchant Storefront and such physical address is provided by the Merchant Storefront so the physical address may not be the actual physical address of the Merchant Storefront.

7. Upon information and belief, Defendant Yiwu Lanhome Jewelry Co., Ltd. is a merchant on Alibaba.com, at <https://lanhome.en.alibaba.com/>, where it offers for sale and/or sells Counterfeit Products and with a principal place of business at 4th Floor, Unit 1, Building 101, Siji 6th Zone, Beiyuan Street, Jinhua, Zhejiang, China (Mainland).

8. Upon information and belief, Defendant Ningbo Mateyness Household Co., Ltd. is a merchant on Alibaba.com, at <https://mateyness.en.alibaba.com>, where it offers for sale and/or sells Counterfeit Products and with a principal place of business at 23 Lianzhong Road, Gaoqiao Town, Ningbo, Zhejiang, China (Mainland).

9. Upon information and belief, Defendant Jiangshan Topme Import & Export Co., Ltd. is a merchant on Alibaba.com, at <https://jstuojin.en.alibaba.com/>, where it offers for sale and/or sells Counterfeit Products and with a principal place of business at 21 Changtangding, Shehou Village, Shuangta Street, Jiangshan, Zhejiang, China (Mainland).

10. Upon information and belief, Defendant Yiwu Joyful Commodity Factory is a merchant on Alibaba.com, at <https://ywjoyful.en.alibaba.com/>, where it offers for sale and/or sells Counterfeit Products and with a principal place of business at Floor 1, Unit 3, Bldg. 39, Yi'an Zone 2, Yiwu, Jinhua, Zhejiang, China (Mainland).

11. Upon information and belief, Defendant Huizhou Kangning Industrial Co., Ltd. is a merchant on Alibaba.com, at <https://kangningltd.en.alibaba.com/>, where it offers for sale and/or sells Counterfeit Products and with a principal place of business at Room 3, Floor 14, Block A, Huiyang World Trade Plaza, Intersection of Baiyun Road and Donghua Avenue, Huiyang District, Huizhou City, Guangdong Province, China (Mainland).

12. Upon information and belief, Defendant Ningbo Haishu Greenwell Commodity Industrial Co., Ltd. is a merchant on Alibaba.com, at <https://nbgreenwell.en.alibaba.com/>, where it offers for sale and/or sells Counterfeit Products and with a principal place of business at 911, No. 16, Nanzhan East Road, Haishu Dist., Ningbo, Zhejiang, China (Mainland).

13. Upon information and belief, Defendant Hefei Fengzhisheng Trade Co., Ltd. is a merchant on Alibaba.com, at <https://hffzs.en.alibaba.com/>, where it offers for sale and/or sells Counterfeit Products and with a principal place of business at Room 1806, A#, Lvdilanhai building, Qianshan Road, Hefei, Anhui, China (Mainland).

14. Upon information and belief, Defendant Ningbo Limkong International Trade Co is a merchant on Alibaba.com, at <https://limkong.en.alibaba.com/>, where it offers for sale and/or sells Counterfeit Products and with a principal place of business at Cixi longshan, Ningbo, Zhejiang, China (Mainland).

15. Upon information and belief, Defendant Yiwu Aliyou Commodity Ltd. is a merchant on Alibaba.com, at <https://youmall.en.alibaba.com/>, where it offers for sale and/or sells Counterfeit Products and with a principal place of business at Rm. 302, Unit 5, Bldg. 20, Huangyangmei Zone 1, Beiyuan Street, Yiwu, Jinhua, Zhejiang, China (Mainland).

16. Upon information and belief, Defendant Ningbo Jiewei Kitchenware Co., Ltd. is a merchant on Alibaba.com, at <https://jwkitchenware.en.alibaba.com/>, where it offers for sale and/or sells Counterfeit Products and with a principal place of business at No.402 Building 4, Batou Road 621, Hongjingwan, DaQi Town, Beilun Zone, Ningbo, Zhejiang, China (Mainland)

17. Upon information and belief, Defendant Ningbo Shenghui Plastic Technology Co., Ltd. is a merchant on Alibaba.com, at <https://tech2005.en.alibaba.com/>, where it offers for sale and/or sells Counterfeit Products and with a principal place of business at No.516 Yaojiang Industrial Zone, Jiangbei Area, Ningbo, Zhejiang, China (Mainland)

18. Upon information and belief, the Defendants use aliases in conjunction with the operation of their businesses as set forth in **Amended Schedule "A"** hereto.

19. Upon information and belief, Defendants are the past and present controlling forces behind the sale of products bearing and/or using counterfeits and infringements of Plaintiff's trademark, trade dress, and patent as described herein using at least the Seller IDs.

20. Upon information and belief, Defendants directly engage in unfair competition with Plaintiff by advertising, offering for sale and selling goods bearing and/or using counterfeits and infringements of Plaintiff's trademark, trade dress, and patent to consumers within the United States and this district through several fully interactive, commercial Internet websites and Internet based e-commerce stores operating under, at least, the Alibaba.com, AliExpress.com, Amazon.com, DHgate.com, eBay.com, and/or Wish.com storefronts, the Seller IDs, and any additional domain names, websites and corresponding website URLs or seller identifications and store URL aliases not yet known to Plaintiff. Defendants have purposefully directed some portion of their illegal activities towards consumers in the State of New York through the

advertisement, offer to sell, sale, and/or shipment of counterfeit and infringing goods into the State.

21. Defendants have registered, established or purchased, and maintained the Alibaba.com, AliExpress.com, Amazon.com, DHgate.com, eBay.com, and/or Wish.com storefronts, Seller IDs, and the websites and e-commerce stores operating thereunder. Upon information and belief, Defendants have engaged in fraudulent conduct with respect to the registration of the storefronts and Seller IDs by providing false and/or misleading information to their various registrars and/or to the Internet based e-commerce platforms where they offer for sale and/or sell, during the registration or maintenance process related to their respective Seller ID. Upon information and belief, Defendants have anonymously registered and maintained some of the Seller IDs for the sole purpose of engaging in illegal counterfeiting activities.

22. Upon information and belief, Defendants will continue to register or acquire new seller identification aliases, and consequently new URL addresses in connection therewith, for the purpose of selling and offering for sale goods bearing and/or using counterfeit and confusingly similar imitations of Plaintiff's trademark and trade dress and infringing Plaintiff's patent unless preliminarily and permanently enjoined.

23. Defendants' Internet-based businesses infringe the intellectual property rights of Plaintiff.

24. Defendants' business names, i.e., the Seller IDs, associated payment accounts, and any other alias domain names and seller identification names or store URLs used in connection with the sale of counterfeit and infringing goods bearing and/or using Plaintiffs' respective trademarks, trade dress, and patent are essential components of Defendants' online activities and are the means by which Defendants further their counterfeiting and infringing scheme and cause

harm to Plaintiffs. Moreover, Defendants are using Plaintiff's trademark to drive Internet consumer traffic to their websites and e-commerce stores operating under the Seller IDs, thereby creating and increasing the value of the Seller IDs and decreasing the size and value of Plaintiff's legitimate consumer marketplace at Plaintiffs' expense.

### **COMMON FACTUAL ALLEGATIONS**

#### **Plaintiff's Business, Trademark, Trade Dress, and Patent Rights**

25. Plaintiff sells a unique and revolutionary patented product under the federally registered trademark NEGG<sup>®</sup> that quickly and easily peels hard boiled eggs.

26. Plaintiff has spent substantial time, money and effort in building up and developing consumer recognition, awareness and goodwill in its NEGG<sup>®</sup> mark and NEGG<sup>®</sup> product.

27 The success of the NEGG<sup>®</sup> product is due in part to Plaintiff's marketing and promotional efforts. These efforts include advertising and promotion through television, retailer websites and other internet-based advertising, print, participation in trade shows, among other efforts, including New York.

28. Plaintiff's NEGG<sup>®</sup> product has been featured on television (the Today show, Home Shopping Network), newspapers (New York Times, USA Today) and numerous videos on YouTube, Facebook and other social media sites. Numerous videos featuring Plaintiff's NEGG<sup>®</sup> product have been collectively viewed hundreds of thousands of times, if not millions of times.

29. Plaintiff's NEGG<sup>®</sup> product is proudly manufactured in the United States using the highest quality materials and processes.

30. Plaintiff owns trademark rights, trade dress, and patent rights regarding its NEGG<sup>®</sup> product.

a. Plaintiff is the owner of source identifying trademarks, including NEGG<sup>®</sup> (Reg. No. 5,142,630 attached as **Exhibit 1**) and trade dress shown in **Exhibit 2** that Plaintiff uses to distinguish its unique product. Plaintiff owns the overall combination and arrangement of all non-functional design elements of Plaintiff's product and packaging, including its product insert, which are inherently distinctive and/or have acquired secondary meaning in the mind of the purchasing public.

b. Plaintiff owns a United States patent for its unique NEGG<sup>®</sup> product, including U.S. Patent No. 9,968,211 for PERSONAL EGG PEELER (attached as **Exhibit 3**).

c. Plaintiff also owns copyrights for its packaging, including its product insert.

31. Plaintiff's trademark, trade dress, patent, and copyright rights make it unlawful for competitors to infringe Plaintiff's rights.

a. Because of Plaintiff's NEGG<sup>®</sup> registered trademark, no competitor can lawfully use Plaintiff's NEGG<sup>®</sup> registered trademark in a manner that could cause confusion as to source.

b. Because of Plaintiff's copyrights for its packaging and trade dress rights, no competitor can lawfully copy Plaintiff's copyrighted expression or use packaging that could cause a likelihood of confusion as to the source of the competing product.

c. Because of Plaintiff's patent on its NEGG<sup>®</sup> product, no competitor can lawfully make, use, offer for sale, or sell a competing product that infringes Plaintiff's patent.

32. Like many other rights owners, Plaintiff suffers ongoing daily and sustained violations of its copyright, trademark and patent rights at the hands of counterfeiters and

infringers, such as Defendants herein. Plaintiff is harmed, the consuming public is duped and confused, and the Defendants earn substantial profits in connection with the infringing conduct.

33. In order to combat the harm caused by the combined actions of Defendants and others engaging in similar infringing conduct, Plaintiff has expended significant resources in connection with its intellectual property enforcement efforts. The recent explosion of infringement over the Internet has created an environment that requires companies to expend significant time and money across a wide spectrum of efforts in order to protect both consumers and itself from infringement of its copyrights, trademark rights and patent rights.

34. Upon information and belief, at all times relevant hereto, Defendants in this action had full knowledge of Plaintiff's copyrights, trademark rights, trade dress, and/or patent rights, including Plaintiff's exclusive right to use and license such intellectual property and the goodwill associated therewith.

a. Plaintiff has complied with Section 29 of the Lanham Act (15 U.S.C. § 1111) and has provided actual notice of its trademark registration for NEGG®. See Plaintiff's product insert (**Exhibit 2**).

b. Plaintiff gave written notices of infringement of one or more of its intellectual property rights to Alibaba (Alibaba.com and AliExpress.com) with respect to Seller IDs on **Amended Schedule "A"**. On information and belief, Alibaba then provided written notice of the infringement.

b. Plaintiff gave written notices of infringement of one or more of its intellectual property rights to Amazon with respect to Seller IDs and/or infringing product ASIN numbers on **Amended Schedule "A"**. On information and belief, Amazon then provided

written notice of the infringement to contact email address for each Seller ID of each infringing product ASIN.

c. Plaintiff gave written notice of infringement of one or more of its intellectual property rights to dhgate.com with respect to Seller IDs on **Amended Schedule “A”**. On information and belief, dhgate.com then provided written notice of infringement.

d. Plaintiff gave written notices of infringement of one or more of its intellectual property rights to eBay with respect to Seller IDs on **Amended Schedule “A”**. On information and belief, eBay then provided written notice of the infringement.

e. Plaintiff gave written notices of infringement of one or more of its intellectual property rights to ContextLogic, Inc. (operator of Wish.com) with respect to Seller IDs on **Amended Schedule “A”**. On information and belief, Context Logic then provided written notice of the infringement.

#### **The Online Marketplace Platforms and Defendants’ User Accounts**

35. Alibaba.com, AliExpress.com, Amazon.com, DHgate.com, eBay.com, and Wish.com, are online marketplace platforms which allow manufacturers, wholesalers and other third party merchants, like Defendants, to advertise, distribute, offer for sale, sell and ship their wholesale and retail products originating from China directly to consumers worldwide and specifically to consumers residing in the United States, including New York.

36. Defendants are individuals and/or businesses, who, upon information and belief, are located in China but conduct business in the U.S. and other countries by means of their User Accounts and on their Merchant Storefronts on Wish as well as potentially yet undiscovered additional online marketplace platforms.

37. Through their Merchant Storefronts, Defendants offer for sale and/or sell consumer products, including Counterfeit Products, and target and ship such products to customers located in the U.S., including New York, and throughout the world.

#### **Defendants' Infringing Activities**

38. Upon information and belief, Defendants are promoting and advertising, distributing, selling and/or offering for sale inexpensive copies of Plaintiff's NEGG<sup>®</sup> product in interstate commerce that infringes Plaintiff's trademark rights, trade dress rights, and patent rights (collectively referred to as, "Infringing Product(s)" or "Counterfeit Product(s)"), through the fully interactive Internet based e-commerce stores operating under the Seller IDs.

- a. The packaging for Defendants' competing goods uses identical copies of Plaintiff's Mark for different quality goods.
- b. The packaging for Defendants' competing goods copies large amounts of Plaintiff's copyrighted expression for its packaging, and the similar trade dress creates a likelihood of confusion as to source.
- c. Defendants' competing goods look nearly identical, which creates a likelihood of confusion as to source, as Defendants' competing goods are confusing similar imitations of Plaintiff's product.
- d. Defendants make, use, offer for sale, or sell competing products that infringe Plaintiff's patent.
- e. Some Defendants have used Plaintiff's NEGG<sup>®</sup> trademark on packaging or in advertisements to drive sales.

f. Defendants' competing goods are of a quality substantially and materially different than that of Plaintiff's genuine goods.

g. Defendants sell or offer the infringing goods for a retail price well below the usual retail price of Plaintiff's genuine patented product.

39. Defendants target their business activities towards consumers throughout the United States, including within this district, and conduct pervasive business through the operation of, at least, one fully interactive commercial Internet based e-commerce store via, at least, the Internet marketplace websites Alibaba.com, AliExpress.com, Amazon.com, dhgate.com, eBay.com, and Wish.com, under various Seller IDs, including the Seller IDs in **Amended Schedule "A"**.

40. Defendants have purposefully directed some portion of their illegal activities towards consumers in the State of New York through the advertisement, offer to sell, sale, and/or shipment of infringing goods into the State.

41. Defendants are the past and present controlling forces behind the sale of products that infringe Plaintiff's intellectual property as described herein using at least the Seller IDs in **Amended Schedule "A"** and the Seller IDs associated with the infringing product ASIN numbers, Product IDs, and/or URLs in **Amended Schedule "A"**. Defendants have registered, established or purchased, and maintained their Seller Names.

42. Upon information and belief, some Defendants have anonymously registered and maintained some of the Seller IDs for the sole purpose of engaging in illegal counterfeiting or infringement activities. For instance, on Amazon.com after notice that a particular Seller Name has sold an infringing product with a particular ASIN number, a new Seller Name will be used (e.g. a new "Just Launched Seller") to sell the same infringing product under a new ASIN

number associated with the new Seller Name. The result can be a never ending “Whack-A-Mole” situation where new infringers keep popping up.

43. Upon information and belief, Defendants will continue to register or acquire new Seller ID aliases for the purpose of selling and offering for sale goods that infringe Plaintiff’s trademark rights, trade dress rights, and patent rights unless preliminarily and permanently enjoined.

44. Defendants’ business names, *i.e.*, Seller IDs, associated payment accounts, and any other alias seller identification names used in connection with the sale of infringing goods are essential components of Defendants’ online activities and are one of the means by which Defendants further their infringing scheme and cause harm to Plaintiff. Moreover, Defendants are using without permission Plaintiff’s copyrights, trademarks, trade dress and patents to drive Internet consumer traffic to their e-commerce stores operating under their Seller IDs, thereby increasing the value of the Seller IDs and decreasing the size and value of Plaintiff’s legitimate marketplace and intellectual property rights at Plaintiff’s expense.

#### **Harm to Plaintiff**

45. Upon information and belief, Defendants are concurrently targeting their infringing activities toward consumers and causing harm within this district and elsewhere throughout the United States. As a result, Defendants are harming Plaintiff and the consuming public for Defendants’ own benefit.

46. By their actions, Defendants have created an illegal marketplace operating in parallel to the legitimate marketplace for Plaintiff’s genuine goods. Defendants are causing concurrent and indivisible harm to Plaintiff and the consuming public by (i) depriving Plaintiff and other

third parties of their right to fairly compete for space within search engine results and reducing the visibility of Plaintiff's genuine goods on the World Wide Web, (ii) causing an overall degradation of the value of the goodwill associated with Plaintiff's trademark rights, and (iii) increasing Plaintiff's overall cost to market its goods and educate consumers about its brand via the Internet.

47. Plaintiff is suffering irreparable and indivisible injury and has suffered substantial damages as a result of Defendants' unauthorized and wrongful use of Plaintiff's intellectual property. The natural and intended byproduct of Defendants' actions is the erosion and destruction of the goodwill associated with Plaintiff's name and associated trademarks and the destruction of the legitimate market sector in which it operates.

48. Defendants' infringing products compete directly against Plaintiff's products. Defendants' infringement was a cause in Plaintiff's unit sales decreasing during the last several months over the same time period the previous year. Plaintiff has thus lost profits.

49. Plaintiff has suffered and will suffer irreparable injury as a result of Defendants' continued sale of infringing products, and monetary damages are inadequate to compensate Plaintiff for Defendants' continued sale of infringing products.

a. Defendants sell cheaper and inferior competing egg peeler products that infringe upon Plaintiff's copyrights, trademarks, trade dress, and patents. Defendants' sale of infringing products has caused Plaintiff loss of market share, reputational harm, lost profits and/or jeopardy to Plaintiff's competitive position.

b. Plaintiff cannot effectively exercise its rights under copyright, trademark, trade dress, and patent which also damages Plaintiff's relationship with its actual and/or potential re-sellers.

c. Defendants have infringed in the past and threaten to infringe in the future.

50. Upon information and belief, Defendants' payment and financial accounts are being used by Defendants to accept, receive, and deposit profits from Defendants' trademark counterfeiting and infringing and unfairly competitive activities connected to their Seller IDs and any other alias domain names or seller identification names being used and/or controlled by them.

51. Plaintiff has no adequate remedy at law. Upon information and belief, Defendants are likely to transfer or secret their assets to avoid payment of any monetary judgment awarded to Plaintiff.

52. Defendants would suffer no cognizable harm from ceasing infringing conduct.

a. Defendants have no right to sell products that infringe Plaintiff's copyrights, trademark rights, trade dress rights, and patent rights.

b. Defendants sell other products, so they would suffer little harm if they stopped selling the infringing products at issue in this lawsuit.

c. Plaintiff will suffer great harm to its competitive position and business if Defendants sell products that infringe Plaintiff's rights.

53. The public interest will be served when it protects Plaintiff from infringement of its copyright, trademark and/or patent rights.

54. Defendants are engaging in the above-described illegal counterfeiting and infringing activities knowingly and intentionally or with reckless disregard or willful blindness to Plaintiff's rights. If Defendants' infringing activities are not preliminarily and permanently enjoined by this Court, Plaintiff and the consuming public will continue to be harmed.

**COUNT I - TRADEMARK COUNTERFEITING AND INFRINGEMENT  
PURSUANT TO § 32 OF THE LANHAM ACT (15 U.S.C. § 1114)**

55. Plaintiff hereby adopts and re-alleges the allegations set forth in the preceding paragraphs as if set forth herein.

56. This is an action for trademark counterfeiting and infringement against Defendants based on their use of counterfeit and confusingly similar imitations of Plaintiff's Mark in commerce in connection with the promotion, advertisement, distribution, offering for sale, and sale of the Counterfeit Goods.

57. Specifically, Defendants are promoting and otherwise advertising, selling, offering for sale, and distributing products bearing and/or using counterfeits and/or infringements of one or more of Plaintiff's Mark. Defendants are continuously infringing and inducing others to infringe Plaintiff's Mark by using them to advertise, promote, offer to sell, and/or sell goods bearing and/or using Plaintiff's Mark.

58. Defendants' concurrent counterfeiting and infringing activities are likely to cause and actually are causing confusion, mistake and deception among members of the trade and the general consuming public as to the origin and quality of Defendants' Counterfeit Goods.

59. Defendants' unlawful actions have caused and are continuing to cause unquantifiable damages to Plaintiff and are unjustly enriching Defendants with profits at Plaintiff's expense.

60. Defendants' above-described illegal actions constitute counterfeiting and infringement of Plaintiff's Marks in violation of Plaintiff's rights under § 32 of the Lanham Act, 15 U.S.C. § 1114.

61. Plaintiff has suffered and will continue to suffer irreparable injury and damages due to Defendants' above described activities if Defendants are not preliminarily and permanently enjoined. Additionally, Defendants will continue to wrongfully profit from their illegal activities.

62. Based on Defendants' actions as alleged herein, Plaintiff is entitled to injunctive relief, damages for the irreparable harm that Plaintiff has sustained, and will sustain, as a result of Defendants' unlawful and infringing actions, as alleged herein, and all gains, profits and advantages obtained by Defendants as a result thereof, enhanced discretionary damages, treble damages and/or statutory damages up to \$2,000,000 per counterfeit mark per type of goods sold, offered for sale or distributed and reasonable attorneys' fees and costs.

**COUNT II - FALSE DESIGNATION OF ORIGIN, PASSING OFF & UNFAIR COMPETITION PURSUANT TO § 43(a) OF THE LANHAM ACT (15 U.S.C. § 1125(a))**

63. Plaintiff hereby adopts and re-alleges the allegations set forth in the preceding paragraphs as if set forth herein.

64. Plaintiff's Marks are inherently distinctive and/or have acquired distinctiveness.

65. Upon information and belief, Defendants' Counterfeit Goods using, offered for sale, and sold under copies of Plaintiff's Mark have been widely advertised, offered for sale, and distributed throughout the United States via Internet websites and Internet marketplace websites.

66. Defendants' Counterfeit Goods using, offered for sale and sold under copies of Plaintiff's Mark are virtually identical in appearance to Plaintiff's respective, genuine goods. However, Defendants' Counterfeit Goods are different and likely inferior in quality.

Accordingly, Defendants' activities are likely to cause confusion in the trade and among the general public as to at least the origin or sponsorship of their Counterfeit Goods.

67. Defendants, upon information and belief, have used in connection with their advertisement, offers for sale, and sale of the Counterfeit Goods, false designations of origin and false descriptions and representations, including words or other symbols and trade dress which tend to falsely describe or represent such goods and have caused such goods to enter into commerce with full knowledge of the falsity of such designations of origin and such descriptions and representations, all to Plaintiff's detriment.

68. Defendants have authorized infringing uses of Plaintiff's Mark in Defendants' advertisement and promotion of their counterfeit and infringing branded goods. Defendants have also misrepresented to members of the consuming public that the Counterfeit Goods being advertised and sold by them are genuine, non-infringing goods.

69. Defendants knowingly and willfully used in commerce products and/or packaging designs that are identical or confusingly similar to, and constitute reproductions of Plaintiff's Marks and affixed, applied and used false designations of origin and false and misleading descriptions and representations on or in connection with the manufacturing, importing, exporting, advertising, marketing, promoting, distributing, displaying, offering for sale and/or sale of Counterfeit Products with the intent to cause confusion, to cause mistake and to deceive the purchasing public into believing, in error, that Defendants' substandard Counterfeit Products are Plaintiff's or related products, and/or that Defendants' Counterfeit Products are authorized, sponsored, approved, endorsed or licensed by Plaintiff and/or that Defendants are affiliated, connected or associated with Plaintiff, thereby creating a likelihood of confusion by consumers as to the source of such Counterfeit Products, and allowing Defendants to capitalize on the

goodwill associated with, and the consumer recognition of, the Plaintiff's Marks and products, to Defendants' substantial profit in blatant disregard of Plaintiff's rights.

70. Additionally, Defendants are using counterfeits and infringements of Plaintiff's Mark in order to unfairly compete with Plaintiffs and others for space within search engine organic results, thereby jointly depriving Plaintiffs of a valuable marketing and educational tool which would otherwise be available to Plaintiffs and reducing the visibility of Plaintiff's genuine goods on the World Wide Web.

71. Defendants' above-described actions are in violation of Section 43(a) of the Lanham Act, 15 U.S.C. §1125(a).

72. Plaintiffs have no adequate remedy at law, and have each sustained indivisible injury and damage caused by Defendants' concurrent conduct. Absent an entry of an injunction by this Court, Defendants will continue to wrongfully reap profits and Plaintiff will continue to suffer irreparable injury to their respective goodwill and business reputations, as well as monetary damages.

73. Based on Defendants' wrongful conduct, Plaintiff is entitled to injunctive relief as well as monetary damages and other remedies as provided by the Lanham Act, including damages that Plaintiff has sustained and will sustain as a result of Defendants' illegal and infringing actions as alleged herein, and all gains, profits and advantages obtained by Defendants as a result thereof, enhanced discretionary damages and reasonable attorneys' fees and costs.

### **COUNT III – PATENT INFRINGEMENT (35 U.S.C. § 271(a))**

74. Plaintiff hereby adopts and re-alleges the allegations set forth in the preceding paragraphs as if set forth herein.

75. Plaintiff is the owner of U.S. Patent No. 9,968,211 (“the ‘211 patent”), issued May 15, 2018, for “PERSONAL EGG PEELER” and which covers Plaintiff’s NEGG® product. A true and correct copy of which is attached as **Exhibit 3**.

76. Defendants have infringed and continue to infringe the ‘211 patent either directly or indirectly through acts of contributory infringement or inducement in violation of 35 U.S.C. § 271, by making, using, selling, importing and/or offering to sell infringing products, namely the personal egg peelers that are nearly identical to Plaintiff’s NEGG® product. .

77. Defendants’ infringement, contributory infringement and/or inducement to infringe has injured Plaintiff and it, therefore, is entitled to recover damages adequate to compensate it for such infringement, but in no event less than a reasonable royalty.

78. Defendants’ infringement, contributory infringement and/or inducement to infringe has been willful and deliberate because Defendants have notice of or knew of the ‘211 patent and have nonetheless injured and will continue to injure Plaintiff, unless and until this Court enters an injunction, which prohibits further infringement and specifically enjoins further manufacture, use, sale, importation and/or offer for sale of products or services that come within the scope of the ‘211 patent.

79. Based on Defendants’ wrongful conduct, Plaintiff is entitled to injunctive relief as well as monetary damages and other remedies as provided by the Patent Act, including damages that Plaintiff has sustained and will sustain as a result of Defendants’ illegal and infringing actions as alleged herein, enhanced discretionary damages and reasonable attorneys’ fees and costs.

**COUNT IV - COMMON LAW UNFAIR COMPETITION**

80. Plaintiff hereby adopts and re-allege the allegations set forth in the preceding paragraphs as if set forth herein.

81. This is an action against Defendants based on their promotion, advertisement, distribution, sale, and/or offering for sale of goods bearing and/or using marks that are virtually identical, both visually and phonetically, to Plaintiff's Mark in violation of New York's common law of unfair competition.

82. Specifically, Defendants are promoting and otherwise advertising, selling, offering for sale, and distributing goods bearing and/or using counterfeits and infringements of Plaintiff's Marks. Defendants are also using counterfeits and infringements of Plaintiff's Mark to unfairly compete with Plaintiff and others for (i) space in search engine results across an array of search terms and (ii) visibility on the World Wide Web.

83. Defendants' infringing activities are likely to cause and actually are causing confusion, mistake, and deception among members of the trade and the general consuming public as to the origin and quality of Defendants' products by their use of Plaintiff's Mark.

84. Plaintiff has no adequate remedy at law and are suffering irreparable injury and damages as a result of Defendants' actions.

85. As a result of Defendants' actions alleged herein, Plaintiff is entitled to injunctive relief, an order granting Plaintiff's damages and Defendants' profits stemming from their infringing activities, and exemplary or punitive damages for Defendants' intentional misconduct.

**COUNT IV - COMMON LAW TRADEMARK INFRINGEMENT**

86. Plaintiff hereby adopts and re-allege the allegations set forth in the preceding paragraphs as if set forth herein.

87. This is an action for common law trademark infringement against Defendants based on their promotion, advertisement, offering for sale, and sale of their Counterfeit Goods bearing and/or using Plaintiff's Mark. Plaintiff is the owners of all common law rights in and to Plaintiff's Mark.

88. Specifically, Defendants, upon information and belief, are manufacturing, promoting and otherwise advertising, distributing, offering for sale, and selling goods bearing and/or using infringements of Plaintiff's Marks.

89. Defendants' infringing activities are likely to cause and actually are causing confusion, mistake and deception among members of the trade and the general consuming public as to the origin and quality of Defendants' Counterfeit Goods bearing and/or using Plaintiff's Mark.

90. Plaintiff has no adequate remedy at law and is suffering damages and irreparable injury as a result of Defendants' actions.

**PRAYER FOR RELIEF**

WHEREFORE, Plaintiff demands judgment on all Counts of this Complaint and an award of equitable relief and monetary relief against Defendants as follows:

a. Entry of temporary, preliminary and permanent injunctions pursuant to 15 U.S.C. § 1116, 35 U.S.C. § 283, and Federal Rule of Civil Procedure 65 enjoining Defendants, their agents, representatives, servants, employees, and all those acting in concert or participation

therewith, from manufacturing or causing to be manufactured, importing, advertising or promoting, distributing, selling or offering to sell their Counterfeit Goods; from infringing, counterfeiting, or diluting Plaintiff's Mark; from using Plaintiff's Mark, or any mark or trade dress similar thereto, in connection with the sale of any unauthorized goods; from using any logo, trade name or trademark or trade dress that may be calculated to falsely advertise the services or goods of Defendants as being sponsored by, authorized by, endorsed by, or in any way associated with Plaintiff; from falsely representing themselves as being connected with Plaintiff, through sponsorship or association, or engaging in any act that is likely to falsely cause members of the trade and/or of the purchasing public to believe any goods or services of Defendants are in any way endorsed by, approved by, and/or associated with Plaintiff; from using any reproduction, counterfeit, infringement, copy, or colorable imitation of Plaintiff's Mark in connection with the publicity, promotion, sale, or advertising of any goods sold by Defendants; from affixing, applying, annexing or using in connection with the sale of any goods, a false description or representation, including words or other symbols tending to falsely describe or represent Defendants' goods as being those of Plaintiff, or in any way endorsed by Plaintiff and from offering such goods in commerce; from engaging in search engine optimization strategies using colorable imitations of Plaintiff's name or trademark; from further infringement, inducement and contributory infringement of the patent-in-suit; and from otherwise unfairly competing with Plaintiff.

c. Entry of an Order that, upon Plaintiff's request, any Internet marketplace website operators and/or administrators that are provided with notice of the injunction, including but not limited to Amazon.com, dhgate.com, eBay.com, Bonanza.com, Walmart.com, Alibaba.com, and AliExpress.com, and ContextLogic, Inc., which operates the Wish.com platform, identify any e-

mail address known to be associated with Defendants' respective Seller ID, and cease facilitating access to any or all e-commerce stores through which Defendants engage in the promotion, offering for sale, and/or sale of goods bearing and/or using counterfeits and/or infringements of Plaintiff's Mark.

d. Entry of an Order that, upon Plaintiff's request, any Internet marketplace website operators and/or administrators who are provided with notice of the injunction, including but not limited to Amazon.com, dhgate.com, eBay.com, Bonanza.com, Walmart.com, Alibaba.com, and AliExpress.com, and ContextLogic, Inc., which operates the Wish.com platform, permanently remove any and all listings and associated images of goods bearing and/or using counterfeits and/or infringements of Plaintiff's Mark via the e-commerce stores operating under the Seller IDs, including any and all listings and images of goods bearing and/or using counterfeits and/or infringements of Plaintiff's Mark linked to the same seller or linked to any other alias seller identification name being used and/or controlled by Defendants to promote, offer for sale and/or sell goods bearing and/or using counterfeits and/or infringements of Plaintiff's Mark.

e. Entry of an Order that, upon Plaintiff's request, any Internet marketplace website operators and/or administrators who are provided with notice of the injunction, including but not limited to Amazon.com, dhgate.com, eBay.com, Bonanza.com, Walmart.com, Alibaba.com, and AliExpress.com, and ContextLogic, Inc., which operates the Wish.com platform, immediately cease fulfillment of and sequester all goods of each Defendant bearing and/or using one or more of Plaintiff's Marks in its inventory, possession, custody, or control, and surrender those goods to Plaintiff.

f. Entry of an order requiring Defendants to account to and pay Plaintiff for all profits and damages resulting from Defendants' trademark counterfeiting and infringing and unfairly

competitive activities and that the award to Plaintiff be trebled, as provided for under 15 U.S.C. §1117, or, at Plaintiff's election with respect to Count I, that Plaintiffs be awarded statutory damages from each Defendant in the amount of two million dollars (\$2,000,000.00) per each counterfeit trademark used and product sold, as provided by 15 U.S.C. §1117(c)(2) of the Lanham Act.

g. Entry of an award pursuant to 15 U.S.C. § 1117 (a) and (b) of Plaintiff's costs and reasonable attorneys' fees and investigative fees associated with bringing this action.

h. Entry an order awarding Plaintiff damages adequate to compensate for the infringement of its patent, but in no event less than a reasonable royalty for the use made of the invention by the Defendants, together with interest and costs as fixed by the Court pursuant to 35 U.S.C. § 284 and that the award be trebled as provided for under 35 U.S.C. §284.

i. Entry of an Order finding that this case is exceptional and an award to Plaintiff of its attorney fees and costs as provided by for under 35 U.S.C. § 205.

j. Entry of an Order that, upon Plaintiff's request, any financial institutions, payment processors, banks, escrow services, money transmitters, or marketplace platforms, including but not limited to, including the Alibaba Group d/b/a Alibaba.com and Aliexpress.com ("Alibaba") payment services (*e.g.*, Alipay.com Co., Ltd., Ant Financial Services), Amazon Payments, Inc. ("Amazon"), eBay Inc. ("eBay"), PayPal Inc. ("PayPal"), Payoneer Inc. ("Payoneer"), Dunhuang Group d/b/a DHgate.com ("DHgate") payment services DHpay.com, PingPong Global Solutions, Inc. ("PingPong"), and Context Logic, Inc. ("Context Logic") and their related companies and affiliates, identify and restrain all funds, up to and including the total amount of judgment, in all financial accounts and/or sub-accounts used in connection with the Seller IDs or other domain names, alias seller identification names, or e-commerce store names or store URLs used by

Defendants presently or in the future, as well as any other related accounts of the same customer(s) and any other accounts which transfer funds into the same financial institution account(s), to be surrendered to Plaintiff in partial satisfaction of the monetary judgment entered herein.

k. Entry of an award of pre-judgment interest on the judgment amount.

l. Entry of an order for any further relief as the Court may deem just and proper.

**DEMAND FOR JURY TRIAL**

Plaintiff respectfully demands a trial by jury on all claims.

Respectfully submitted,

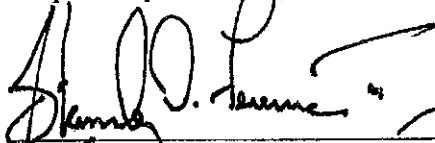

Stanley D. Ference III (SF 1086)  
courts@ferencelaw.com

FERENCE & ASSOCIATES LLC  
409 Broad Street  
Pittsburgh, PA 15143  
Telephone: (412) 741-8400  
Facsimile: (412) 741-9292

Attorneys for Plaintiff  
Airigan Solutions, Inc.

Dated: July 19, 2018

*Of Counsel:*

Brian Samuel Malkin  
Norbert Lazar  
FERENCE & ASSOCIATES LLC  
409 Broad Street  
Pittsburgh, Pennsylvania 15143  
Telephone: (412) 741-8400  
Facsimile: (412) 741-9292

AMENDED SCHEDULE "A"

Def No.	Defendant by Seller ID	URL of Defendant's Merchant Storefront	ASIN/Prod ID/URL
1	Yiyu Lanhome Jewelry Co., Ltd.	<a href="https://lanhome.en.alibaba.com/">https://lanhome.en.alibaba.com/</a>	<a href="http://www.alibaba.com/product-gs/60770761889/Hotting_Egg_Shell_Peeler_Peeling_Kitchen.html">http://www.alibaba.com/product-gs/60770761889/Hotting_Egg_Shell_Peeler_Peeling_Kitchen.html</a>
2	Ningbo Mateyness Household Co., Ltd	<a href="https://mateyness.en.alibaba.com/">https://mateyness.en.alibaba.com/</a>	<a href="http://www.alibaba.com/product-gs/60757892975/Magic_Boiled_Egg_Peeler_Shell_Remover.html">http://www.alibaba.com/product-gs/60757892975/Magic_Boiled_Egg_Peeler_Shell_Remover.html</a>
3	Jiangshan Topme Import & Export Co., Ltd.	<a href="https://jstuojin.en.alibaba.com/">https://jstuojin.en.alibaba.com/</a>	<a href="http://www.alibaba.com/product-gs/60744710801/Boiled_Egg_Shell_Peeler_Peeling_Kitchen.html">http://www.alibaba.com/product-gs/60744710801/Boiled_Egg_Shell_Peeler_Peeling_Kitchen.html</a>
4	Yiyu Joyful Commodity Factory	<a href="https://yiwioyful.en.alibaba.com/">https://yiwioyful.en.alibaba.com/</a>	<a href="http://www.alibaba.com/product-gs/6075568387/Boiled_Egg_Stripper_Shell_Peeler_Peeling.html">http://www.alibaba.com/product-gs/6075568387/Boiled_Egg_Stripper_Shell_Peeler_Peeling.html</a>
5	Huizhou Kangning Industrial Co., Ltd	<a href="https://kangningltd.en.alibaba.com/">https://kangningltd.en.alibaba.com/</a>	<a href="http://www.alibaba.com/product-gs/60756633069/Boiled_Egg_Peeler.html">http://www.alibaba.com/product-gs/60756633069/Boiled_Egg_Peeler.html</a>
6	Ningbo Haishu Greenwell Commodity Industrial Co., Ltd.	<a href="https://ngreenwell.en.alibaba.com/">https://ngreenwell.en.alibaba.com/</a>	<a href="http://www.alibaba.com/product-gs/60765626122/Greenwell_hot_sale_egg_peeler_magic.html">http://www.alibaba.com/product-gs/60765626122/Greenwell_hot_sale_egg_peeler_magic.html</a>
7	Hefei Fengzhisheng Trade Co., Ltd	<a href="https://hfzfs.en.alibaba.com/">https://hfzfs.en.alibaba.com/</a>	<a href="http://www.alibaba.com/product-gs/60751634037/Hot_Selling_Egg_shell_peeler_stripper.html">http://www.alibaba.com/product-gs/60751634037/Hot_Selling_Egg_shell_peeler_stripper.html</a>
8	Ningbo Limkong International Trade Co	<a href="https://limkong.en.alibaba.com/">https://limkong.en.alibaba.com/</a>	<a href="https://www.alibaba.com/product-detail/Fun-Cooking-Gadgets-for-the-Family_60776409729.html">https://www.alibaba.com/product-detail/Fun-Cooking-Gadgets-for-the-Family_60776409729.html</a>
9	Yiyu Aliyou Commodity Ltd.	<a href="https://yyoumall.en.alibaba.com/">https://yyoumall.en.alibaba.com/</a>	<a href="https://www.alibaba.com/product-detail/Boiled-Egg-Shell-Peeler-Peeling-Kitchen_60752731931.html">https://www.alibaba.com/product-detail/Boiled-Egg-Shell-Peeler-Peeling-Kitchen_60752731931.html</a>
10	Ningbo Jiewei Kitchenware Co., Ltd.	<a href="https://jwkitchenware.en.alibaba.com/">https://jwkitchenware.en.alibaba.com/</a>	<a href="https://www.alibaba.com/product-detail/Customize-Egg-Peeler-Hard-Boiled-Egg_60754569548.html">https://www.alibaba.com/product-detail/Customize-Egg-Peeler-Hard-Boiled-Egg_60754569548.html</a>
11	Ningbo Shenghui Plastic Technology Co., Ltd.	<a href="https://tech2005.en.alibaba.com">https://tech2005.en.alibaba.com</a>	<a href="http://www.alibaba.com/product-gs/6075568387/Boiled_Egg_Stripper_Shell_Peeler_Peeling.html">http://www.alibaba.com/product-gs/6075568387/Boiled_Egg_Stripper_Shell_Peeler_Peeling.html</a>
12	Shenzhen Valkind Technology Co., Ltd.	<a href="https://valkind.aliexpress.com/store/203288">https://valkind.aliexpress.com/store/203288</a>	<a href="http://www.aliexpress.com/item/Plastic-Egg-Shell-Peeler-Egg-Slicer-Cutter-Egg-Shell-Separator-Scissors-Peeling-Tool-Household-Kitchen-Cooking/32858171417.html">http://www.aliexpress.com/item/Plastic-Egg-Shell-Peeler-Egg-Slicer-Cutter-Egg-Shell-Separator-Scissors-Peeling-Tool-Household-Kitchen-Cooking/32858171417.html</a>
13	Pawprint Store	<a href="https://www.aliexpress.com/store/2675065">https://www.aliexpress.com/store/2675065</a>	<a href="http://www.aliexpress.com/item/2018-New-arrival-Egg-Shell-Peeler-Egg-Slicer-Cutter-Peeling-Tool-egg-Peeler-Kitchen-Tool-Home/3284925596.html">http://www.aliexpress.com/item/2018-New-arrival-Egg-Shell-Peeler-Egg-Slicer-Cutter-Peeling-Tool-egg-Peeler-Kitchen-Tool-Home/3284925596.html</a>
14	1st kitchen Store	<a href="https://www.aliexpress.com/store/3450001">https://www.aliexpress.com/store/3450001</a>	<a href="http://www.aliexpress.com/item/VYSHION-Egg-Shell-Peelers-Slicer-Remover-Dividers-Plastic-Egg-Scissor-Cutter-Handle-Egg-Tools-Drop-Shipping/32857952797.html">http://www.aliexpress.com/item/VYSHION-Egg-Shell-Peelers-Slicer-Remover-Dividers-Plastic-Egg-Scissor-Cutter-Handle-Egg-Tools-Drop-Shipping/32857952797.html</a>
15	Good Lifestyle Store	<a href="https://www.aliexpress.com/store/2496049">https://www.aliexpress.com/store/2496049</a>	<a href="http://www.aliexpress.com/item/Egg-Shell-Peeler-Egg-Slicer-Cutter-Kitchen-Peeling-Tool-Egg-Peeler-for-Home-Kitchen-Accessories-Egg/3285276486.html">http://www.aliexpress.com/item/Egg-Shell-Peeler-Egg-Slicer-Cutter-Kitchen-Peeling-Tool-Egg-Peeler-for-Home-Kitchen-Accessories-Egg/3285276486.html</a>
16	Hinta Droshipping Store	<a href="https://www.aliexpress.com/store/3155043">https://www.aliexpress.com/store/3155043</a>	<a href="http://www.aliexpress.com/item/Creative-Cooked-Egg-Peeler-Hard-Boiled-Egg-Shell-Peeler-Peeling-Kitchen-Tool/32860312736.html">http://www.aliexpress.com/item/Creative-Cooked-Egg-Peeler-Hard-Boiled-Egg-Shell-Peeler-Peeling-Kitchen-Tool/32860312736.html</a>
17	WholeWorld Store	<a href="https://www.aliexpress.com/store/1463728">https://www.aliexpress.com/store/1463728</a>	<a href="http://www.aliexpress.com/item/Cooked-Egg-Peeler-Hard-Boiled-Boiled-Eggs-Shell-Peelers-Peeling-Kitchen-Tool-Home-egg-slicer/32858078185.html">http://www.aliexpress.com/item/Cooked-Egg-Peeler-Hard-Boiled-Boiled-Eggs-Shell-Peelers-Peeling-Kitchen-Tool-Home-egg-slicer/32858078185.html</a>
18	StarStar Store	<a href="https://believe.aliexpress.com/store/2784019">https://believe.aliexpress.com/store/2784019</a>	<a href="http://www.aliexpress.com/item/Cooked-Egg-Peeler-Hard-Boiled-Boiled-Eggs-Shell-Peelers-Peeling-Kitchen-Tool-Home-egg-slicer/32857902336.html">http://www.aliexpress.com/item/Cooked-Egg-Peeler-Hard-Boiled-Boiled-Eggs-Shell-Peelers-Peeling-Kitchen-Tool-Home-egg-slicer/32857902336.html</a>
19	CCTX Store	<a href="https://www.aliexpress.com/store/3369024">https://www.aliexpress.com/store/3369024</a>	<a href="http://www.aliexpress.com/item/2018-Cooked-Egg-Peeler-Hard-Boiled-Boiled-Egg-Shell-Peeler-Peeling-Kitchen-Tool-AP6/32860921958.html">http://www.aliexpress.com/item/2018-Cooked-Egg-Peeler-Hard-Boiled-Boiled-Egg-Shell-Peeler-Peeling-Kitchen-Tool-AP6/32860921958.html</a>
20	MUQGEW Pets Store	<a href="https://www.aliexpress.com/store/3243081">https://www.aliexpress.com/store/3243081</a>	<a href="http://www.aliexpress.com/item/Cooked-Egg-Peeler-Hard-whisk-Boiled-Egg-Shell-poached-Peeling-Kitchen-Tool-shape-for-egg-cutter/32857081274.html">http://www.aliexpress.com/item/Cooked-Egg-Peeler-Hard-whisk-Boiled-Egg-Shell-poached-Peeling-Kitchen-Tool-shape-for-egg-cutter/32857081274.html</a>
21	KitchenMall Store	<a href="https://www.aliexpress.com/store/3402012">https://www.aliexpress.com/store/3402012</a>	<a href="http://www.aliexpress.com/item/New-Arrival-Egg-Shell-Peeler-Egg-Slicer-Cutter-Kitchen-Peeling-Tool-Egg-Peeler-For-Home-Kitchen/32854213530.html">http://www.aliexpress.com/item/New-Arrival-Egg-Shell-Peeler-Egg-Slicer-Cutter-Kitchen-Peeling-Tool-Egg-Peeler-For-Home-Kitchen/32854213530.html</a>
22	Me&My House China Textile Retail Store	<a href="https://www.aliexpress.com/store/2227092">https://www.aliexpress.com/store/2227092</a>	<a href="http://www.aliexpress.com/item/Peeler-Cooked-Egg-Peeler-Hard-Boiled-Boiled-Egg-Shell-Peeler-Peeling-Kitchen-Tool-Drop-Shipping/3285923071.html">http://www.aliexpress.com/item/Peeler-Cooked-Egg-Peeler-Hard-Boiled-Boiled-Egg-Shell-Peeler-Peeling-Kitchen-Tool-Drop-Shipping/3285923071.html</a>

## AMENDED SCHEDULE "A"

Def No.	Defendant by Seller ID	URL of Defendant's Merchant Storefront	ASIN/Prod ID/URL
23	punkgirl store	<a href="https://www.aliexpress.com/store/1191437">https://www.aliexpress.com/store/1191437</a>	<a href="http://www.aliexpress.com/item/Egg-Peeler-Shell-Peeling-Machine-Hard-Boiled-Convenient-Kitchen-Paring-Tool-TB-Sale/32882869849.html">http://www.aliexpress.com/item/Egg-Peeler-Shell-Peeling-Machine-Hard-Boiled-Convenient-Kitchen-Paring-Tool-TB-Sale/32882869849.html</a>
24	Umaru's Houseware Store	<a href="https://www.aliexpress.com/store/2400091">https://www.aliexpress.com/store/2400091</a>	<a href="http://www.aliexpress.com/item/2018-New-Arrival-Egg-Shell-Peeler-Egg-Slicer-Cutter-Peeling-Tool-Hard-Boiled-Egg-Peeler-Kitchen/32872366542.html">http://www.aliexpress.com/item/2018-New-Arrival-Egg-Shell-Peeler-Egg-Slicer-Cutter-Peeling-Tool-Hard-Boiled-Egg-Peeler-Kitchen/32872366542.html</a>
25	Fantasy Garden & Life House Store	<a href="https://www.aliexpress.com/store/2802127">https://www.aliexpress.com/store/2802127</a>	<a href="http://www.aliexpress.com/item/Egg-Shell-Peeler-Egg-Slicer-Cutter-Peeling-Tool-Boiled-Egg-Peeler-Home-Egg-Slicer-Kitchen-Gadgets/3286659668.html">http://www.aliexpress.com/item/Egg-Shell-Peeler-Egg-Slicer-Cutter-Peeling-Tool-Boiled-Egg-Peeler-Home-Egg-Slicer-Kitchen-Gadgets/3286659668.html</a>
26	My House Store Store	<a href="https://www.aliexpress.com/store/2948247">https://www.aliexpress.com/store/2948247</a>	<a href="http://www.aliexpress.com/item/Egg-Tool-Cooked-Egg-Peeler-Hard-Kitchen-Tool-Boiled-Egg-Shell-Peeler-Peeling-Cooking-Tools-18MAR23/32859694732.html">http://www.aliexpress.com/item/Egg-Tool-Cooked-Egg-Peeler-Hard-Kitchen-Tool-Boiled-Egg-Shell-Peeler-Peeling-Cooking-Tools-18MAR23/32859694732.html</a>
27	Brunch Lifestyle Store	<a href="https://www.aliexpress.com/store/3239033">https://www.aliexpress.com/store/3239033</a>	<a href="http://www.aliexpress.com/item/2018-New-Arrival-Egg-Shell-Peeler-Plastic-Creative-Egg-Slicer-Cutter-Peeling-Tool-Egg-Peeler-Kitchen/32858119756.html">http://www.aliexpress.com/item/2018-New-Arrival-Egg-Shell-Peeler-Plastic-Creative-Egg-Slicer-Cutter-Peeling-Tool-Egg-Peeler-Kitchen/32858119756.html</a>
28	Transhome Dropshipping Kitchen Store	<a href="https://www.aliexpress.com/store/1713132">https://www.aliexpress.com/store/1713132</a>	<a href="http://www.aliexpress.com/item/Transhome-1Pcs-Negg-Egg-Peeler-Scissors-Slicers-Dividers-Egg-Tools-Kitchen-Gadgets-Accessories-Drop-Shipping/32852209033.html">http://www.aliexpress.com/item/Transhome-1Pcs-Negg-Egg-Peeler-Scissors-Slicers-Dividers-Egg-Tools-Kitchen-Gadgets-Accessories-Drop-Shipping/32852209033.html</a>
29	Believer Store	<a href="https://www.aliexpress.com/store/3676003">https://www.aliexpress.com/store/3676003</a>	<a href="http://www.aliexpress.com/item/1pcs-Negg-Egg-Peeler-Scissors-Slicers-Dividers-Egg-Tools-Kitchen-Gadgets-Accessories-Drop-Shipping/32868876371.html">http://www.aliexpress.com/item/1pcs-Negg-Egg-Peeler-Scissors-Slicers-Dividers-Egg-Tools-Kitchen-Gadgets-Accessories-Drop-Shipping/32868876371.html</a>
30	JOY HOME Mail	<a href="https://www.aliexpress.com/store/1997038">https://www.aliexpress.com/store/1997038</a>	<a href="http://www.aliexpress.com/item/Negg-Egg-Shell-Peeler-Kitchen-Tool-Home-Egg-Peeling-Tool/32856628180.html">http://www.aliexpress.com/item/Negg-Egg-Shell-Peeler-Kitchen-Tool-Home-Egg-Peeling-Tool/32856628180.html</a>
31	MIAONV Store	<a href="https://www.aliexpress.com/store/2885134">https://www.aliexpress.com/store/2885134</a>	<a href="http://www.aliexpress.com/item/1pcs-Negg-Egg-Peeler-Scissors-Slicers-Dividers-Egg-Tools-Kitchen-Gadgets-Accessories-Drop-Shipping/32871422984.html">http://www.aliexpress.com/item/1pcs-Negg-Egg-Peeler-Scissors-Slicers-Dividers-Egg-Tools-Kitchen-Gadgets-Accessories-Drop-Shipping/32871422984.html</a>
32	Dropship Hotsale Store	<a href="https://www.aliexpress.com/store/3617125">https://www.aliexpress.com/store/3617125</a>	<a href="http://www.aliexpress.com/item/Dropshipping-New-Clever-Negg-Boiled-Egg-Peeler-Magic-Egg-Shell-Dividers-Eggshell-Separator-Peeling-Kitchen-Gadget/32867913687.html">http://www.aliexpress.com/item/Dropshipping-New-Clever-Negg-Boiled-Egg-Peeler-Magic-Egg-Shell-Dividers-Eggshell-Separator-Peeling-Kitchen-Gadget/32867913687.html</a>
33	Hallelujah	<a href="https://www.aliexpress.com/store/326030">https://www.aliexpress.com/store/326030</a>	<a href="http://www.aliexpress.com/item/200pcs-New-Arrival-Negg-Egg-Shell-Peeler-Kitchen-Tools-Egg-Peeling-Tools-egg-scissors/32863710267.html">http://www.aliexpress.com/item/200pcs-New-Arrival-Negg-Egg-Shell-Peeler-Kitchen-Tools-Egg-Peeling-Tools-egg-scissors/32863710267.html</a>
34	Shanghai Jenny	<a href="https://www.aliexpress.com/store/1971468">https://www.aliexpress.com/store/1971468</a>	<a href="http://www.aliexpress.com/item/1pcs-Negg-Egg-Peeler-Scissors-Slicers-Dividers-Egg-Tools-Kitchen-Gadgets-Accessories-Drop-Shipping/32871470424.html">http://www.aliexpress.com/item/1pcs-Negg-Egg-Peeler-Scissors-Slicers-Dividers-Egg-Tools-Kitchen-Gadgets-Accessories-Drop-Shipping/32871470424.html</a>
35	FLYXF Store	<a href="https://www.aliexpress.com/store/4033097">https://www.aliexpress.com/store/4033097</a>	<a href="http://www.aliexpress.com/item/1pcs-Negg-Egg-Peeler-Scissors-Slicers-Dividers-Egg-Tools-Kitchen-Gadgets-Accessories-Drop-Shipping/32883983270.html">http://www.aliexpress.com/item/1pcs-Negg-Egg-Peeler-Scissors-Slicers-Dividers-Egg-Tools-Kitchen-Gadgets-Accessories-Drop-Shipping/32883983270.html</a>
36	Getyoursave	<a href="https://www.aliexpress.com/store/1491004">https://www.aliexpress.com/store/1491004</a>	<a href="http://www.aliexpress.com/item/1pcs-Negg-Egg-Peeler-Scissors-Slicers-Dividers-Egg-Tools-Kitchen-Gadgets-Accessories-Drop-Shipping/32871454519.html">http://www.aliexpress.com/item/1pcs-Negg-Egg-Peeler-Scissors-Slicers-Dividers-Egg-Tools-Kitchen-Gadgets-Accessories-Drop-Shipping/32871454519.html</a>
37	My SweetHome Store	<a href="https://www.aliexpress.com/store/1656297">https://www.aliexpress.com/store/1656297</a>	<a href="http://www.aliexpress.com/item/Egg-Shell-Peeler-Peeling-Tool-Boiled-Egg-Peeler-for-Kitchen-Egg-Boiled-Egg-Peeler/32871670399.html">http://www.aliexpress.com/item/Egg-Shell-Peeler-Peeling-Tool-Boiled-Egg-Peeler-for-Kitchen-Egg-Boiled-Egg-Peeler/32871670399.html</a>
38	Lucky Yune Store	<a href="https://www.aliexpress.com/store/3659035">https://www.aliexpress.com/store/3659035</a>	<a href="http://www.aliexpress.com/item/THE-NEGG-BOILED-EGG-PEELER/32859587697.html">http://www.aliexpress.com/item/THE-NEGG-BOILED-EGG-PEELER/32859587697.html</a>
39	Transhome Dropshipping Kitchen Store	<a href="https://www.aliexpress.com/store/1713132">https://www.aliexpress.com/store/1713132</a>	<a href="https://www.aliexpress.com/item/Transhome-10-Seconds-Egg-Stripper-Negg-Egg-Peeler-The-Goods-For-Kitchen-Dropshipping-Wholesalers-Bestsellers/32865657523.html">https://www.aliexpress.com/item/Transhome-10-Seconds-Egg-Stripper-Negg-Egg-Peeler-The-Goods-For-Kitchen-Dropshipping-Wholesalers-Bestsellers/32865657523.html</a>
40	Miss U Store	<a href="https://www.aliexpress.com/store/4086002">https://www.aliexpress.com/store/4086002</a>	<a href="https://www.aliexpress.com/item/10-Seconds-Egg-Stripper-Negg-Egg-Peeler-The-Goods-For-Kitchen-Dropshipping-Wholesalers-Bestsellers/1000005839719.html">https://www.aliexpress.com/item/10-Seconds-Egg-Stripper-Negg-Egg-Peeler-The-Goods-For-Kitchen-Dropshipping-Wholesalers-Bestsellers/1000005839719.html</a>
41	Honey Kitchen Store	<a href="https://www.aliexpress.com/store/1784165">https://www.aliexpress.com/store/1784165</a>	<a href="https://www.aliexpress.com/item/BOILED-EGG-PEELER-Egg-Shell-Peeler-Egg-Scissors-Slicers-Dividers-Cutter-Peeling-Tool-for-Home-Kitchen/32871051082.html">https://www.aliexpress.com/item/BOILED-EGG-PEELER-Egg-Shell-Peeler-Egg-Scissors-Slicers-Dividers-Cutter-Peeling-Tool-for-Home-Kitchen/32871051082.html</a>
42	Warm Harbor Store	<a href="https://www.aliexpress.com/store/3204007">https://www.aliexpress.com/store/3204007</a>	<a href="https://www.aliexpress.com/item/10T-Egg-Shell-Peeler-Egg-Slicer-Cutter-Peeling-Tool-egg-Peeler-Kitchen-Tool-Home-Egg-Peeler/32860403350.html">https://www.aliexpress.com/item/10T-Egg-Shell-Peeler-Egg-Slicer-Cutter-Peeling-Tool-egg-Peeler-Kitchen-Tool-Home-Egg-Peeler/32860403350.html</a>

AMENDED SCHEDULE "A"

Def No.	Defendant by Seller ID	URL of Defendant's Merchant Storefront	ASIN/Prod ID/URL
43	Leading your life Store	<a href="https://www.aliexpress.com/store/2937009">https://www.aliexpress.com/store/2937009</a>	<a href="https://www.aliexpress.com/item/Egg-Shell-Peeler-Egg-Slicer-Cutter-Peeling-Tool-Boiled-Egg-Peeler-Home-Egg-Slicer-Kitchen-Gadgets/32862704199.html">https://www.aliexpress.com/item/Egg-Shell-Peeler-Egg-Slicer-Cutter-Peeling-Tool-Boiled-Egg-Peeler-Home-Egg-Slicer-Kitchen-Gadgets/32862704199.html</a>
44	Practical Kitchen Store	<a href="https://www.aliexpress.com/store/3111053">https://www.aliexpress.com/store/3111053</a>	<a href="https://www.aliexpress.com/item/Egg-Shell-Peeler-Egg-Slicer-Cutter-Peeling-Tool-Boiled-Egg-Peeler-Home-Egg-Slicer-Kitchen-Gadgets/32872427379.html">https://www.aliexpress.com/item/Egg-Shell-Peeler-Egg-Slicer-Cutter-Peeling-Tool-Boiled-Egg-Peeler-Home-Egg-Slicer-Kitchen-Gadgets/32872427379.html</a>
45	KingPet Market Store	<a href="https://www.aliexpress.com/store/2881374">https://www.aliexpress.com/store/2881374</a>	<a href="https://www.aliexpress.com/item/Egg-Shell-Peeler-Egg-Slicer-Cutter-Peeling-Tool-Boiled-Egg-Peeler-Home-Egg-Slicer-Kitchen-Gadgets/32874321909.html">https://www.aliexpress.com/item/Egg-Shell-Peeler-Egg-Slicer-Cutter-Peeling-Tool-Boiled-Egg-Peeler-Home-Egg-Slicer-Kitchen-Gadgets/32874321909.html</a>
46	CeHe Store	<a href="https://ghe.aliexpress.com/store/1543548">https://ghe.aliexpress.com/store/1543548</a>	<a href="https://www.aliexpress.com/item/GOONBO-1-pc-Egg-Peeler-Plastic-Egg-Shell-Peeler-Egg-Slicer-Cutter-Peeling-Tool-Dropshipping/32868928327.html">https://www.aliexpress.com/item/GOONBO-1-pc-Egg-Peeler-Plastic-Egg-Shell-Peeler-Egg-Slicer-Cutter-Peeling-Tool-Dropshipping/32868928327.html</a>
47	Your assistant Store	<a href="https://www.aliexpress.com/store/3862025">https://www.aliexpress.com/store/3862025</a>	<a href="https://www.aliexpress.com/item/2018-New-arrival-Egg-Shell-Peeler-Egg-Slicer-Cutter-Peeling-Tool-egg-Peeler-Kitchen-Tool-Home/32875592879.html">https://www.aliexpress.com/item/2018-New-arrival-Egg-Shell-Peeler-Egg-Slicer-Cutter-Peeling-Tool-egg-Peeler-Kitchen-Tool-Home/32875592879.html</a>
48	WOWCC Dropshipping Store	<a href="https://www.aliexpress.com/store/1232637">https://www.aliexpress.com/store/1232637</a>	<a href="https://www.aliexpress.com/item/WOWCC-Egg-Shell-Peeler-Egg-Slicer-Cutter-Peeling-Tool-Egg-Peeler-Kitchen-Tool-Home-Egg-Slicer/32854360787.html">https://www.aliexpress.com/item/WOWCC-Egg-Shell-Peeler-Egg-Slicer-Cutter-Peeling-Tool-Egg-Peeler-Kitchen-Tool-Home-Egg-Slicer/32854360787.html</a>
49	AmyHome Store Store	<a href="https://www.aliexpress.com/store/2662193">https://www.aliexpress.com/store/2662193</a>	<a href="https://www.aliexpress.com/item/Plastic-Egg-Shell-Peeler-Egg-Slicer-Cutter-Egg-Shell-Separator-Scissors-Peeling-Tool-Household-Kitchen-Cooking/32876287402.html">https://www.aliexpress.com/item/Plastic-Egg-Shell-Peeler-Egg-Slicer-Cutter-Egg-Shell-Separator-Scissors-Peeling-Tool-Household-Kitchen-Cooking/32876287402.html</a>
50	Common Truth	<a href="https://tr.aliexpress.com/store/1380874">https://tr.aliexpress.com/store/1380874</a>	<a href="https://www.aliexpress.com/item/Household-Egg-Shell-Peeler-Egg-Slicer-Cutter-Egg-Shell-Separator-Scissors-Peeling-Tool-Plastic-Kitchen-Cooking/32858167454.html">https://www.aliexpress.com/item/Household-Egg-Shell-Peeler-Egg-Slicer-Cutter-Egg-Shell-Separator-Scissors-Peeling-Tool-Plastic-Kitchen-Cooking/32858167454.html</a>
51	VDHUK Store	<a href="https://tr.aliexpress.com/store/2970028">https://tr.aliexpress.com/store/2970028</a>	<a href="https://www.aliexpress.com/item/2018-New-Egg-Shell-Peeler-Kitchen-Egg-Cutter-Tool-Home-Egg-Slicer-Scissors-Dividers/32857193442.html">https://www.aliexpress.com/item/2018-New-Egg-Shell-Peeler-Kitchen-Egg-Cutter-Tool-Home-Egg-Slicer-Scissors-Dividers/32857193442.html</a>
52	Umaru's Houseware Store	<a href="https://tr.aliexpress.com/store/2400091">https://tr.aliexpress.com/store/2400091</a>	<a href="https://www.aliexpress.com/item/2018-Hot-Sale-Egg-Shell-Peelers-Slicer-Remover-Dividers-Plastic-Egg-Slicer-Cutter-Handle-Egg-Tools/32871152682.html">https://www.aliexpress.com/item/2018-Hot-Sale-Egg-Shell-Peelers-Slicer-Remover-Dividers-Plastic-Egg-Slicer-Cutter-Handle-Egg-Tools/32871152682.html</a>
53	Shop1033157 Store	<a href="https://tr.aliexpress.com/store/1033157">https://tr.aliexpress.com/store/1033157</a>	<a href="https://www.aliexpress.com/item/Plastic-Egg-Shell-Peeler-Egg-Slicer-Cutter-Egg-Shell-Separator-Scissors-Peeling-Tool-Household-Kitchen-Cooking/32868766593.html">https://www.aliexpress.com/item/Plastic-Egg-Shell-Peeler-Egg-Slicer-Cutter-Egg-Shell-Separator-Scissors-Peeling-Tool-Household-Kitchen-Cooking/32868766593.html</a>
54	Best Home lifestyle	<a href="https://tr.aliexpress.com/store/2022020">https://tr.aliexpress.com/store/2022020</a>	<a href="https://www.aliexpress.com/item/Egg-Shell-Peeler-Plastic-Egg-Slicer-Egg-Shell-Separator-Scissors-Peeling-Tool-Household-Kitchen/32892673944.html">https://www.aliexpress.com/item/Egg-Shell-Peeler-Plastic-Egg-Slicer-Egg-Shell-Separator-Scissors-Peeling-Tool-Household-Kitchen/32892673944.html</a>
55	Loving Warm Home	<a href="https://tr.aliexpress.com/store/237015">https://tr.aliexpress.com/store/237015</a>	<a href="https://www.aliexpress.com/item/Egg-Shell-Peeler-Plastic-Egg-Slicer-Egg-Shell-Separator-Scissors-Peeling-Tool-Household-Kitchen-Cooking/32884904338.html">https://www.aliexpress.com/item/Egg-Shell-Peeler-Plastic-Egg-Slicer-Egg-Shell-Separator-Scissors-Peeling-Tool-Household-Kitchen-Cooking/32884904338.html</a>
56	TOPATY Store	<a href="https://tr.aliexpress.com/store/3174028">https://tr.aliexpress.com/store/3174028</a>	<a href="https://www.aliexpress.com/item/Plastic-Egg-Shell-Peeler-Egg-Slicer-Egg-Shell-Separator-Scissors-Peeling-Tool-Household-Kitchen-Cooking/328769356216.html">https://www.aliexpress.com/item/Plastic-Egg-Shell-Peeler-Egg-Slicer-Egg-Shell-Separator-Scissors-Peeling-Tool-Household-Kitchen-Cooking/328769356216.html</a>
57	Sunshine-store	<a href="https://tr.aliexpress.com/store/407893">https://tr.aliexpress.com/store/407893</a>	<a href="https://www.aliexpress.com/item/2018-New-Arrival-Egg-Shell-Peeler-Egg-Slicer-Cutter-Peeling-Egg-Separator-Tool-Kitchen-Accessories-Home/32864649696.html">https://www.aliexpress.com/item/2018-New-Arrival-Egg-Shell-Peeler-Egg-Slicer-Cutter-Peeling-Egg-Separator-Tool-Kitchen-Accessories-Home/32864649696.html</a>
58	Leading lifestyle store	<a href="https://tr.aliexpress.com/store/1389042">https://tr.aliexpress.com/store/1389042</a>	<a href="https://www.aliexpress.com/item/Egg-Shell-Peeler-Egg-Slicer-Cutter-Peeling-Tool-Boiled-Egg-Peeler-Home-Egg-Slicer-Kitchen-Gadgets/32873147815.html">https://www.aliexpress.com/item/Egg-Shell-Peeler-Egg-Slicer-Cutter-Peeling-Tool-Boiled-Egg-Peeler-Home-Egg-Slicer-Kitchen-Gadgets/32873147815.html</a>
59	Sweet dream family center98	<a href="https://tr.aliexpress.com/store/1752437">https://tr.aliexpress.com/store/1752437</a>	<a href="https://www.aliexpress.com/item/SDFC-Egg-Shell-Peeler-Egg-Slicer-Cutter-Peeling-Tool-egg-Peeler-Kitchen-Tool-Home-Egg-Slicer/32883000579.html">https://www.aliexpress.com/item/SDFC-Egg-Shell-Peeler-Egg-Slicer-Cutter-Peeling-Tool-egg-Peeler-Kitchen-Tool-Home-Egg-Slicer/32883000579.html</a>
60	Poodle XiaoCoCos Shop Store	<a href="https://he.aliexpress.com/store/3508046">https://he.aliexpress.com/store/3508046</a>	<a href="https://www.aliexpress.com/item/Plastic-Egg-Shell-Peeler-Egg-Slicer-Cutter-Peeling-Tool-egg-Peeler-Kitchen-Tool-Home-Egg-Slicer-Stainless/32869262671.html">https://www.aliexpress.com/item/Plastic-Egg-Shell-Peeler-Egg-Slicer-Cutter-Peeling-Tool-egg-Peeler-Kitchen-Tool-Home-Egg-Slicer-Stainless/32869262671.html</a>
61	Innovation Drinkware Store	<a href="https://www.aliexpress.com/store/3106052">https://www.aliexpress.com/store/3106052</a>	<a href="https://www.aliexpress.com/item/Shell-Peeler-Egg-Slicer-Cutter-Peeling-Tool-Boiled-Egg-Peeler-Home-Egg-Slicer-Kitchen-Gadgets/3286940511.html">https://www.aliexpress.com/item/Shell-Peeler-Egg-Slicer-Cutter-Peeling-Tool-Boiled-Egg-Peeler-Home-Egg-Slicer-Kitchen-Gadgets/3286940511.html</a>
62	CHINA REASARD Store	<a href="https://www.aliexpress.com/store/1440008">https://www.aliexpress.com/store/1440008</a>	<a href="https://www.aliexpress.com/item/2018-New-arrival-Egg-Shell-Peeler-Egg-Slicer-Cutter-Peeling-Tool-egg-Peeler-Kitchen-Tool-Home/32856970557.html">https://www.aliexpress.com/item/2018-New-arrival-Egg-Shell-Peeler-Egg-Slicer-Cutter-Peeling-Tool-egg-Peeler-Kitchen-Tool-Home/32856970557.html</a>
63	Enjoys Life Store	<a href="https://www.aliexpress.com/store/2947149">https://www.aliexpress.com/store/2947149</a>	<a href="https://www.aliexpress.com/item/Egg-Shell-Peeler-Egg-Slicer-Cutter-Peeling-Tool-Boiled-Egg-Peeler-Home-Egg-Slicer-Kitchen-Gadgets/32888789296.html">https://www.aliexpress.com/item/Egg-Shell-Peeler-Egg-Slicer-Cutter-Peeling-Tool-Boiled-Egg-Peeler-Home-Egg-Slicer-Kitchen-Gadgets/32888789296.html</a>
64	Noachic cafe Store	<a href="https://he.aliexpress.com/store/3178001">https://he.aliexpress.com/store/3178001</a>	<a href="https://www.aliexpress.com/item/MOCMA-Egg-Shell-Peeler-Egg-Slicer-Cutter-Peeling-Tool-egg-Peeler-Kitchen-Tool-Home-Egg-Slicer/32862761602.html">https://www.aliexpress.com/item/MOCMA-Egg-Shell-Peeler-Egg-Slicer-Cutter-Peeling-Tool-egg-Peeler-Kitchen-Tool-Home-Egg-Slicer/32862761602.html</a>
65	Aladingting Store	<a href="https://www.aliexpress.com/store/3630083">https://www.aliexpress.com/store/3630083</a>	<a href="https://www.aliexpress.com/item/Plastic-Egg-Shell-Peeler-Egg-Slicer-Cutter-Egg-Shell-Separator-Scissors-Peeling-Tool-Household-Kitchen-Cooking/32858123627.html">https://www.aliexpress.com/item/Plastic-Egg-Shell-Peeler-Egg-Slicer-Cutter-Egg-Shell-Separator-Scissors-Peeling-Tool-Household-Kitchen-Cooking/32858123627.html</a>

AMENDED SCHEDULE "A"

Def No.	Defendant by Seller ID	URL of Defendant's Merchant Storefront	ASIN/Prod ID/URL
66	Institute of Food	<a href="https://www.aliexpress.com/store/1866025">https://www.aliexpress.com/store/1866025</a>	<a href="https://www.aliexpress.com/item/Plastic-Manual-Eggs-Shell-Peelers-Accessories/32885962968.html">https://www.aliexpress.com/item/Plastic-Manual-Eggs-Shell-Peelers-Accessories/32885962968.html</a>
67	SKU Co., Ltd. Store	<a href="https://www.aliexpress.com/store/2344160">https://www.aliexpress.com/store/2344160</a>	<a href="https://www.aliexpress.com/item/Manual-Eggs-Shell-Peelers-Accessories/32885930768.html">https://www.aliexpress.com/item/Manual-Eggs-Shell-Peelers-Accessories/32885930768.html</a>
68	sweethome-sale	<a href="https://www.aliexpress.com/store/1656297">https://www.aliexpress.com/store/1656297</a>	<a href="https://www.aliexpress.com/item/Kitchen-Manual-Eggs-Shell-Peelers-Accessories/32886127704.html">https://www.aliexpress.com/item/Kitchen-Manual-Eggs-Shell-Peelers-Accessories/32886127704.html</a>
69	Fashion Store A8	<a href="https://www.aliexpress.com/store/1907984">https://www.aliexpress.com/store/1907984</a>	<a href="https://www.aliexpress.com/item/Instantly-Hard-Boiled-Egg-Shell-Peelers-Red-Black-Yellow-White/32875295957.html">https://www.aliexpress.com/item/Instantly-Hard-Boiled-Egg-Shell-Peelers-Red-Black-Yellow-White/32875295957.html</a>
70	Worldwide Dropshipping Store	<a href="https://www.aliexpress.com/store/3204074">https://www.aliexpress.com/store/3204074</a>	<a href="https://www.aliexpress.com/item/Egg-Shell-Peelers-Kitchen-Cooking-Tool/32868346443.html">https://www.aliexpress.com/item/Egg-Shell-Peelers-Kitchen-Cooking-Tool/32868346443.html</a>
71	Dolly's Arting Life	<a href="https://www.aliexpress.com/store/2348069">https://www.aliexpress.com/store/2348069</a>	<a href="https://www.aliexpress.com/item/Hard-Boiled-Egg-Shell-Peelers-Detachable-High-Quality-Egg-Shell-Peelers/32885187978.html">https://www.aliexpress.com/item/Hard-Boiled-Egg-Shell-Peelers-Detachable-High-Quality-Egg-Shell-Peelers/32885187978.html</a>
72	goodfeet-Store	<a href="https://www.aliexpress.com/store/3359003">https://www.aliexpress.com/store/3359003</a>	<a href="https://www.aliexpress.com/item/APC-Manually-Egg-Shell-Peelers-Portable-Hard-Boiled-Egg-Shell-Separator-TV-Remove-Peelers-Magic-Amazing-Eggshell/32888161812.html">https://www.aliexpress.com/item/APC-Manually-Egg-Shell-Peelers-Portable-Hard-Boiled-Egg-Shell-Separator-TV-Remove-Peelers-Magic-Amazing-Eggshell/32888161812.html</a>
73	Go-Homing Store	<a href="https://www.aliexpress.com/store/2665213">https://www.aliexpress.com/store/2665213</a>	<a href="https://www.aliexpress.com/item/Cooked-Egg-Peelers-Hard-Boiled-Egg-Shell-Peelers-Peelers-Kitchen-Tool-3-16/32856829561.html">https://www.aliexpress.com/item/Cooked-Egg-Peelers-Hard-Boiled-Egg-Shell-Peelers-Peelers-Kitchen-Tool-3-16/32856829561.html</a>
74	YY Lucky Store	<a href="https://www.aliexpress.com/store/3883028">https://www.aliexpress.com/store/3883028</a>	<a href="https://www.aliexpress.com/item/Cooked-Egg-Shell-Peelers-Peelers-to-Cooked-Chicken-Eggshell-Tools/32862174731.html">https://www.aliexpress.com/item/Cooked-Egg-Shell-Peelers-Peelers-to-Cooked-Chicken-Eggshell-Tools/32862174731.html</a>
75	Unique Life Store	<a href="https://www.aliexpress.com/store/3567033">https://www.aliexpress.com/store/3567033</a>	<a href="https://www.aliexpress.com/item/Egg-Peelers-Cutter-Peelers-Tool-Kitchen-Egg-Shell-Separator/32880865071.html">https://www.aliexpress.com/item/Egg-Peelers-Cutter-Peelers-Tool-Kitchen-Egg-Shell-Separator/32880865071.html</a>
76	Sunfei	<a href="https://www.amazon.com/s?merchant=AIA1FVBU0XG2">https://www.amazon.com/s?merchant=AIA1FVBU0XG2</a>	B01NATZUY2, B01N235WK4
77	Some Interesting Store	<a href="https://www.amazon.com/s?merchant=A1V9U5HSNY2CRF">https://www.amazon.com/s?merchant=A1V9U5HSNY2CRF</a>	B07BFT9WBZ
78	Zfitci	<a href="https://www.amazon.com/s?merchant=A300Y12PDYH5KA">https://www.amazon.com/s?merchant=A300Y12PDYH5KA</a>	B07CKPV969
79	Wishesport	<a href="https://www.amazon.com/s?merchant=A1IEB5Q82D2SKP">https://www.amazon.com/s?merchant=A1IEB5Q82D2SKP</a>	B07DBY9WHZ
80	SMYTSshop	<a href="https://www.amazon.com/SMYTSshop/b/ref=bi_dp_sweb_1727385011?ie=UTF8&amp;node=1727385011&amp;field-lbr_brands_browse-bin=SMYTSshop">https://www.amazon.com/SMYTSshop/b/ref=bi_dp_sweb_1727385011?ie=UTF8&amp;node=1727385011&amp;field-lbr_brands_browse-bin=SMYTSshop</a>	B07BHQKQTD
81	Formemory	<a href="https://www.amazon.com/s?merchant=A24E40DAXST04Q">https://www.amazon.com/s?merchant=A24E40DAXST04Q</a>	B07CV9Y5S8
82	Baoblaze	<a href="https://www.amazon.com/s?merchant=A3C8YKGW3F5UJNV">https://www.amazon.com/s?merchant=A3C8YKGW3F5UJNV</a>	B07D394Y6F
83	Dolity Home	<a href="https://www.amazon.com/s?merchant=A1784CWL7LX7P">https://www.amazon.com/s?merchant=A1784CWL7LX7P</a>	B07D36YT2W
84	Brandon Trollpoe	<a href="https://www.amazon.com/s?merchant=A2UF2EWMUJLRAZI">https://www.amazon.com/s?merchant=A2UF2EWMUJLRAZI</a>	B07B2H3YQD, B07B2H6YB7
85	Hofeis	<a href="https://www.amazon.com/s?merchant=A2ZHB0FS74E6FF">https://www.amazon.com/s?merchant=A2ZHB0FS74E6FF</a>	B07BD5576N, B07BD554PR
86	TilLary	<a href="https://www.amazon.com/s?merchant=A2W9F9DMUJ65XV1">https://www.amazon.com/s?merchant=A2W9F9DMUJ65XV1</a>	B07D7V5YVZ
87	HOMERFUL	<a href="https://www.amazon.com/Homeful/b/ref=wb_bi_hsx_ski_web_15180153011?ie=UTF8&amp;node=15180153011&amp;field-lbr_brands_browse-bin=Homeful">https://www.amazon.com/Homeful/b/ref=wb_bi_hsx_ski_web_15180153011?ie=UTF8&amp;node=15180153011&amp;field-lbr_brands_browse-bin=Homeful</a>	Any of the following ASIN numbers: B07CGN969R, B07CVBB6G1, B07B2H6YB7, B07BYW9X9JM, B07DFZHL5T, B07CBNK5VB, B07CMLGFW1, B07B2H3YQD, B07BD5576N, B07D1251GY, B07D6MK5V2, B07CWFQXX8, B07D5W33BW, B07CV9R266, B07DSVXMQM, B07CH5N88D, B07D5WDCBX, B07D1Q4VRD, B07C7VQ57W, B07DFZ4NJ4

AMENDED SCHEDULE "A"

Def No.	Defendant by Seller ID	URL of Defendant's Merchant Storefront	ASIN/Prod ID/URL
88	Labu Store	<a href="https://www.amazon.com/s?merchant=A1EFTOGAHLWG425">https://www.amazon.com/s?merchant=A1EFTOGAHLWG425</a>	Any of the following ASIN numbers: ASIN: B07CGN969R, B07CVBB6G1, B07B2H6YB7, B07BYWX91M, B07DFZHL5T, B07CBNK5VB, B07CM1GFW1, B07B2H3YQD, B07BD5576N, B07D1251GY, B07D6MK5V2, B07CWFXQX8, B07D5W33BW, B07CV9R266, B07D5VXMQM, B07CH5N88D, B07DSWDCBX, B07D1Q4VRD, B07CVQ57W, B07DFZANJ4
89	ordon.pictr	<a href="https://www.amazon.com/s?merchant=A3H540W73B5R1HB">https://www.amazon.com/s?merchant=A3H540W73B5R1HB</a>	Any of the following ASIN numbers: ASIN: B07CGN969R, B07CVBB6G1, B07B2H6YB7, B07BYWX91M, B07DFZHL5T, B07CBNK5VB, B07CM1GFW1, B07B2H3YQD, B07BD5576N, B07D1251GY, B07D6MK5V2, B07CWFXQX8, B07D5W33BW, B07CV9R266, B07D5VXMQM, B07CH5N88D, B07DSWDCBX, B07D1Q4VRD, B07CVQ57W, B07DFZANJ4
90	Brad2016	<a href="https://www.dhgate.com/store/20127433">https://www.dhgate.com/store/20127433</a>	<a href="https://www.dhgate.com/product/plastic-egg-shell-peeler-egg-slicer-cutter/412601483.html">https://www.dhgate.com/product/plastic-egg-shell-peeler-egg-slicer-cutter/412601483.html</a>
91	dhgate_factory01	<a href="https://www.dhgate.com/store/20644561">https://www.dhgate.com/store/20644561</a>	<a href="https://www.dhgate.com/store/product/2018-new-arrival-egg-shell-peeler-egg-slicer/411068513.html">https://www.dhgate.com/store/product/2018-new-arrival-egg-shell-peeler-egg-slicer/411068513.html</a>
92	dhgatecp_merchant	<a href="https://www.dhgate.com/store/20748377">https://www.dhgate.com/store/20748377</a>	<a href="https://www.dhgate.com/store/product/plastic-egg-shell-peeler-egg-slicer-cutter/411089748.html">https://www.dhgate.com/store/product/plastic-egg-shell-peeler-egg-slicer-cutter/411089748.html</a>
93	greatseller	<a href="https://www.ebay.com/usr/areatseller">https://www.ebay.com/usr/areatseller</a>	<a href="https://www.ebay.com/itm/Hard-boiled-Eggs-Peeler-Hard-boiled-Egg-Peeler-the-negg-Hard-boiled-Egg-Peeler/13077459319">https://www.ebay.com/itm/Hard-boiled-Eggs-Peeler-Hard-boiled-Egg-Peeler-the-negg-Hard-boiled-Egg-Peeler/13077459319</a> <a href="https://www.ebay.com/itm/Hard-boiled-Egg-Peeler-Hard-boiled-the-negg-Egg-Peeler-Hard-boiled-Egg-Peeler/113079032121">https://www.ebay.com/itm/Hard-boiled-Egg-Peeler-Hard-boiled-the-negg-Egg-Peeler-Hard-boiled-Egg-Peeler/113079032121</a>
94	zouelbr_0	<a href="https://www.ebay.com/usr/zouelbr_0">https://www.ebay.com/usr/zouelbr_0</a>	<a href="https://www.ebay.com/itm/The-Negg-Hard-boiled-Egg-Peeler-Solutions-Egg-Peeler-Hard-Boiled-NIB/123191929460">https://www.ebay.com/itm/The-Negg-Hard-boiled-Egg-Peeler-Solutions-Egg-Peeler-Hard-Boiled-NIB/123191929460</a>
95	2017jummei	<a href="https://www.ebay.com/usr/2017jummei">https://www.ebay.com/usr/2017jummei</a>	<a href="https://www.ebay.com/itm/The-Negg-Hard-boiled-Egg-Peeler-Solutions-Egg-Peeler-Hard-Boiled-NIB/273304414722">https://www.ebay.com/itm/The-Negg-Hard-boiled-Egg-Peeler-Solutions-Egg-Peeler-Hard-Boiled-NIB/273304414722</a>
96	melvoodas0	<a href="https://www.ebay.com/usr/melvoodas0">https://www.ebay.com/usr/melvoodas0</a>	<a href="https://www.ebay.com/itm/The-Negg-Hard-boiled-Egg-Peeler-Solutions-Egg-Peeler-Hard-Boiled-NIB/253692916710">https://www.ebay.com/itm/The-Negg-Hard-boiled-Egg-Peeler-Solutions-Egg-Peeler-Hard-Boiled-NIB/253692916710</a>
97	best_4youu	<a href="https://www.ebay.com/usr/best_4youu">https://www.ebay.com/usr/best_4youu</a>	<a href="https://www.ebay.com/itm/The-Negg-Hard-boiled-Egg-Peeler-Solutions-Egg-Peeler-Hard-Boiled-NIB/253692944819">https://www.ebay.com/itm/The-Negg-Hard-boiled-Egg-Peeler-Solutions-Egg-Peeler-Hard-Boiled-NIB/253692944819</a>
98	trustworthy404	<a href="https://www.ebay.com/usr/trustworthy404">https://www.ebay.com/usr/trustworthy404</a>	<a href="https://www.ebay.com/itm/GIVEAWAY-PRICE-The-Negg-Hard-boiled-Egg-Peeler-Solution-New-Easy-Fast-Fun/123195686383">https://www.ebay.com/itm/GIVEAWAY-PRICE-The-Negg-Hard-boiled-Egg-Peeler-Solution-New-Easy-Fast-Fun/123195686383</a>
99	2015ilbruc	<a href="https://www.ebay.com/usr/2015ilbruc">https://www.ebay.com/usr/2015ilbruc</a>	<a href="https://www.ebay.com/itm/THE-NEGG-BOILED-EGG-PEELER-RED/253349759131">https://www.ebay.com/itm/THE-NEGG-BOILED-EGG-PEELER-RED/253349759131</a>
100	pacificfantastic	<a href="https://www.ebay.com/usr/pacificfantastic">https://www.ebay.com/usr/pacificfantastic</a>	<a href="https://www.ebay.com/itm/THE-NEGG-BOILED-EGG-PEELER-YELLOW/192569771545">https://www.ebay.com/itm/THE-NEGG-BOILED-EGG-PEELER-YELLOW/192569771545</a>
101	silvishop15	<a href="https://www.ebay.com/usr/silvishop15">https://www.ebay.com/usr/silvishop15</a>	<a href="https://www.ebay.com/itm/THE-NEGG-BOILED-EGG-PEELER-RED-home-kitchen-tool/1924271319693">https://www.ebay.com/itm/THE-NEGG-BOILED-EGG-PEELER-RED-home-kitchen-tool/1924271319693</a>
102	xxcdianzi	<a href="https://www.ebay.com/usr/xxcdianzi">https://www.ebay.com/usr/xxcdianzi</a>	<a href="https://www.ebay.com/itm/Egg-Peeler-Solutions-Egg-Peeler-Hard-Boiled-NIBThe-Negg-Hard-Boiled-Multicolor/32331137257">https://www.ebay.com/itm/Egg-Peeler-Solutions-Egg-Peeler-Hard-Boiled-NIBThe-Negg-Hard-Boiled-Multicolor/32331137257</a>
103	nalimat	<a href="https://www.ebay.com/usr/nalimat">https://www.ebay.com/usr/nalimat</a>	<a href="https://www.ebay.com/itm/Egg-Shell-Peeler-Egg-Slicer-Cutter-Peeling-Tool-egg-Peeler-Kitchen-Tool-home/232904767876">https://www.ebay.com/itm/Egg-Shell-Peeler-Egg-Slicer-Cutter-Peeling-Tool-egg-Peeler-Kitchen-Tool-home/232904767876</a>

AMENDED SCHEDULE "A"

Def No.	Defendant by Seller ID	URL of Defendant's Merchant Storefront	ASIN/Prod ID/URL
104	kitsimple sale	<a href="https://www.ebay.com/usr/kitsimple sale">https://www.ebay.com/usr/kitsimple sale</a>	<a href="https://www.ebay.com/itm/New-Egg-Shell-Peeler-Egg-Slicer-RED-Peeling-Tool-egg-Peeler-Kitchen-Tool-Egg/263774467518">https://www.ebay.com/itm/New-Egg-Shell-Peeler-Egg-Slicer-RED-Peeling-Tool-egg-Peeler-Kitchen-Tool-Egg/263774467518</a>
105	hanoune_9816	<a href="https://www.ebay.com/usr/hanoune_9816">https://www.ebay.com/usr/hanoune_9816</a>	<a href="https://www.ebay.com/itm/New-Egg-Shell-Peeler-Egg-Slicer-Cutter-Peeling-Tool-egg-Peeler-Kitchen-Tool-Egg/192551929794">https://www.ebay.com/itm/New-Egg-Shell-Peeler-Egg-Slicer-Cutter-Peeling-Tool-egg-Peeler-Kitchen-Tool-Egg/192551929794</a>
106	ama1-gadgets-shop	<a href="https://www.ebay.com/usr/ama1-gadgets-shop">https://www.ebay.com/usr/ama1-gadgets-shop</a>	<a href="https://www.ebay.com/itm/Egg-Shell-Peeler-Egg-Slicer-Cutter-Peeling-Tool-egg-Peeler-Kitchen-Tool-Home/113022421287">https://www.ebay.com/itm/Egg-Shell-Peeler-Egg-Slicer-Cutter-Peeling-Tool-egg-Peeler-Kitchen-Tool-Home/113022421287</a>
107	ultimate1 seller	<a href="https://www.ebay.com/usr/ultimate1 seller">https://www.ebay.com/usr/ultimate1 seller</a>	<a href="https://www.ebay.com/itm/New-Egg-Shell-Peeler-Egg-Slicer-Cutter-Peeling-Tool-egg-Peeler-Kitchen-Tool-Home/253729663381">https://www.ebay.com/itm/New-Egg-Shell-Peeler-Egg-Slicer-Cutter-Peeling-Tool-egg-Peeler-Kitchen-Tool-Home/253729663381</a>
108	yihangjc	<a href="https://www.ebay.com/usr/yihangjc">https://www.ebay.com/usr/yihangjc</a>	<a href="https://www.ebay.com/itm/The-Neggs-Red-Black-White-Yellow-By-Airigen-Solutions-Egg-Peeler-Hard-Boiled-NIB/292628390888">https://www.ebay.com/itm/The-Neggs-Red-Black-White-Yellow-By-Airigen-Solutions-Egg-Peeler-Hard-Boiled-NIB/292628390888</a>
109	cofgers	<a href="https://www.ebay.com/usr/cofgers">https://www.ebay.com/usr/cofgers</a>	<a href="https://www.ebay.com/itm/The-Neggs-Hard-boiled-Egg-Peeler-Solutions-Egg-Peeler-Hard-Boiled-NIB/323321008780">https://www.ebay.com/itm/The-Neggs-Hard-boiled-Egg-Peeler-Solutions-Egg-Peeler-Hard-Boiled-NIB/323321008780</a>
110	qwwdss	<a href="https://www.ebay.com/usr/qwwdss">https://www.ebay.com/usr/qwwdss</a>	<a href="https://www.ebay.com/itm/The-Neggs-Hard-boiled-Egg-Peeler-Solutions-Egg-Peeler-Hard-Boiled-NIB/223039638674">https://www.ebay.com/itm/The-Neggs-Hard-boiled-Egg-Peeler-Solutions-Egg-Peeler-Hard-Boiled-NIB/223039638674</a>
111	HENGCHU	<a href="https://www.wish.com/merchant/555d6c3638eb01b1296deca8e">https://www.wish.com/merchant/555d6c3638eb01b1296deca8e</a>	<a href="https://www.wish.com/g/5aa397e2eaf55117a1135ffid">https://www.wish.com/g/5aa397e2eaf55117a1135ffid</a>
112	fengdingluo hua	<a href="https://www.wish.com/merchant/58ccad88fa2f4571564c0098">https://www.wish.com/merchant/58ccad88fa2f4571564c0098</a>	<a href="https://www.wish.com/g/5ae1a96b570859174c5f9ad">https://www.wish.com/g/5ae1a96b570859174c5f9ad</a>
113	Coolyard	<a href="https://www.wish.com/merchant/5a994ed618d9210f967e0de">https://www.wish.com/merchant/5a994ed618d9210f967e0de</a>	<a href="https://www.wish.com/g/5aab9f68304257110a780ab">https://www.wish.com/g/5aab9f68304257110a780ab</a>
114	vakin2018	<a href="https://www.wish.com/merchant/5374509f7360464b6b25f8fb">https://www.wish.com/merchant/5374509f7360464b6b25f8fb</a>	<a href="https://www.wish.com/g/5b0cb99bc13755386a171543">https://www.wish.com/g/5b0cb99bc13755386a171543</a>
115	gudaobigworld	<a href="https://www.wish.com/merchant/58256ca227e1ab4891f66fc">https://www.wish.com/merchant/58256ca227e1ab4891f66fc</a>	<a href="https://www.wish.com/g/5a9931c21a8c2172842a20fb">https://www.wish.com/g/5a9931c21a8c2172842a20fb</a>
116	Mygiftshop	<a href="https://www.wish.com/merchant/5800b5517462b55fd23f319">https://www.wish.com/merchant/5800b5517462b55fd23f319</a>	<a href="https://www.wish.com/g/5a9ccee05c7e80b0e75986cae">https://www.wish.com/g/5a9ccee05c7e80b0e75986cae</a>
117	PowerMup	<a href="https://www.wish.com/merchant/59e7f8e20a332a5f879688a0">https://www.wish.com/merchant/59e7f8e20a332a5f879688a0</a>	<a href="https://www.wish.com/g/5aa962047c74933704fe806e">https://www.wish.com/g/5aa962047c74933704fe806e</a>
118	WildLion	<a href="https://www.wish.com/merchant/5a9e6935b9609f19fc287c15">https://www.wish.com/merchant/5a9e6935b9609f19fc287c15</a>	<a href="https://www.wish.com/g/5ac8a738c7e80b08143859c2">https://www.wish.com/g/5ac8a738c7e80b08143859c2</a>
119	youneedit	<a href="https://www.wish.com/merchant/5a167bb20c47f37889e88a54">https://www.wish.com/merchant/5a167bb20c47f37889e88a54</a>	<a href="https://www.wish.com/g/5aac602fbd784c5096f3a332">https://www.wish.com/g/5aac602fbd784c5096f3a332</a>
120	AdventureHelper	<a href="https://www.wish.com/merchant/5a9a1b57b125ab05e5d0d06">https://www.wish.com/merchant/5a9a1b57b125ab05e5d0d06</a>	<a href="https://www.wish.com/g/5af29747ce2c7013f6f657fc">https://www.wish.com/g/5af29747ce2c7013f6f657fc</a>
121	Lilang Da Technology	<a href="https://www.wish.com/merchant/56fb8ae85558c2865934047">https://www.wish.com/merchant/56fb8ae85558c2865934047</a>	<a href="https://www.wish.com/g/5a3cb4b3ebeb0879b4a66037">https://www.wish.com/g/5a3cb4b3ebeb0879b4a66037</a>
122	Unbeatable sale .com	<a href="https://www.wish.com/merchant/5877e44ba35cef1278491f32e">https://www.wish.com/merchant/5877e44ba35cef1278491f32e</a>	<a href="https://www.wish.com/g/5ab3e46e1ab08a02cda7f953">https://www.wish.com/g/5ab3e46e1ab08a02cda7f953</a>
123	treebackw18	<a href="https://www.wish.com/merchant/5954a1654b913a627e41e7fa">https://www.wish.com/merchant/5954a1654b913a627e41e7fa</a>	<a href="https://www.wish.com/g/5aaa6f1be7d4840cebca1060">https://www.wish.com/g/5aaa6f1be7d4840cebca1060</a>
124	Fashion-Master	<a href="https://www.wish.com/merchant/54815e6740b37805abe61d30">https://www.wish.com/merchant/54815e6740b37805abe61d30</a>	<a href="https://www.wish.com/g/5ab3524147a0e73f1de9dbd4">https://www.wish.com/g/5ab3524147a0e73f1de9dbd4</a>
125	Rogerww	<a href="https://www.wish.com/merchant/577cd7d7b2715340c1726da">https://www.wish.com/merchant/577cd7d7b2715340c1726da</a>	<a href="https://www.wish.com/g/5ad6ff97a74484496e48a20d">https://www.wish.com/g/5ad6ff97a74484496e48a20d</a>
126	PowerMup	<a href="https://www.wish.com/merchant/59e7f8e20a332a5f879688a0">https://www.wish.com/merchant/59e7f8e20a332a5f879688a0</a>	<a href="https://www.wish.com/g/5aa28449b4784c7636f6f099">https://www.wish.com/g/5aa28449b4784c7636f6f099</a>
127	coververse	<a href="https://www.wish.com/merchant/53426c2b7360467126ed3120">https://www.wish.com/merchant/53426c2b7360467126ed3120</a>	<a href="https://www.wish.com/g/5aab425c1a8c212fb379a01e">https://www.wish.com/g/5aab425c1a8c212fb379a01e</a>
128	Embroidered shop	<a href="https://www.wish.com/merchant/587363c69ad2eb4d4a84b189">https://www.wish.com/merchant/587363c69ad2eb4d4a84b189</a>	<a href="https://www.wish.com/g/5ab88dae7cddb0652fe1fa02c">https://www.wish.com/g/5ab88dae7cddb0652fe1fa02c</a>

AMENDED SCHEDULE "A"

Def No.	Defendant by Seller ID	URL of Defendant's Merchant Storefront	ASIN/Prod ID/URL
129	moralltop	<a href="https://www.wish.com/merchant/55d3e4bf92e9ba122fbdfce4">https://www.wish.com/merchant/55d3e4bf92e9ba122fbdfce4</a>	<a href="https://www.wish.com/c/5aab6675e2ae1746445b4b4">https://www.wish.com/c/5aab6675e2ae1746445b4b4</a>
130	jingsinghuadian	<a href="https://www.wish.com/merchant/5ac9c4952fbbdc92f95f847f">https://www.wish.com/merchant/5ac9c4952fbbdc92f95f847f</a>	<a href="https://www.wish.com/c/5ad25c8ea69e663716e6e53e">https://www.wish.com/c/5ad25c8ea69e663716e6e53e</a>
131	themarvel	<a href="https://www.wish.com/merchant/5829940de18e0736403b2007">https://www.wish.com/merchant/5829940de18e0736403b2007</a>	<a href="https://www.wish.com/c/5a9a87a61c7e97974924e7c">https://www.wish.com/c/5a9a87a61c7e97974924e7c</a>
132	yych2010	<a href="https://www.wish.com/merchant/58368d481d8914896d3058e">https://www.wish.com/merchant/58368d481d8914896d3058e</a>	<a href="https://www.wish.com/c/5a6a6aad95f79f07083c6434">https://www.wish.com/c/5a6a6aad95f79f07083c6434</a>
133	guocangmaoyi	<a href="https://www.wish.com/merchant/5afbf180f8534f5f24740a8">https://www.wish.com/merchant/5afbf180f8534f5f24740a8</a>	<a href="https://www.wish.com/c/5b24766553d6cd078b6d137">https://www.wish.com/c/5b24766553d6cd078b6d137</a>
134	newyange	<a href="https://www.wish.com/merchant/59c228e7235134421d69f5ac">https://www.wish.com/merchant/59c228e7235134421d69f5ac</a>	<a href="https://www.wish.com/c/5af674fa64fef627ca3511ff">https://www.wish.com/c/5af674fa64fef627ca3511ff</a>
135	Hippie's store	<a href="https://www.wish.com/merchant/5866083ba79f44d40f5206a">https://www.wish.com/merchant/5866083ba79f44d40f5206a</a>	<a href="https://www.wish.com/c/5ab078801b3a82117f8b5dee">https://www.wish.com/c/5ab078801b3a82117f8b5dee</a>

# Complaint

## EXHIBIT 1



**UNITED STATES PATENT AND TRADEMARK OFFICE**

UNDER SECRETARY OF COMMERCE FOR INTELLECTUAL PROPERTY AND  
DIRECTOR OF THE UNITED STATES PATENT AND TRADEMARK OFFICE

JULY 3, 2018

PTAS

STANLEY D. FERENCE III  
409 BROAD STREET  
PITTSBURGH, PA 15143

**900456707**

UNITED STATES PATENT AND TRADEMARK OFFICE  
NOTICE OF RECORDATION OF ASSIGNMENT DOCUMENT

THE ENCLOSED DOCUMENT HAS BEEN RECORDED BY THE ASSIGNMENT RECORDATION BRANCH OF THE U.S. PATENT AND TRADEMARK OFFICE. A COMPLETE COPY IS AVAILABLE AT THE ASSIGNMENT SEARCH ROOM ON THE REEL AND FRAME NUMBER REFERENCED BELOW.

PLEASE REVIEW ALL INFORMATION CONTAINED ON THIS NOTICE. THE INFORMATION CONTAINED ON THIS RECORDATION NOTICE REFLECTS THE DATA PRESENT IN THE PATENT AND TRADEMARK ASSIGNMENT SYSTEM. IF YOU SHOULD FIND ANY ERRORS OR HAVE QUESTIONS CONCERNING THIS NOTICE, YOU MAY CONTACT THE ASSIGNMENT RECORDATION BRANCH AT 571-272-3350. PLEASE SEND REQUEST FOR CORRECTION TO: U.S. PATENT AND TRADEMARK OFFICE, MAIL STOP: ASSIGNMENT RECORDATION BRANCH, P.O. BOX 1450, ALEXANDRIA, VA 22313.

RECORDATION DATE: 07/02/2018

REEL/FRAME: 6369/0707  
NUMBER OF PAGES: 2

BRIEF: ASSIGNS THE ENTIRE INTEREST

DOCKET NUMBER: 972.003

ASSIGNOR:  
TORGAN, SHEILA

DOC DATE: 06/01/2018  
CITIZENSHIP: UNITED STATES  
ENTITY: INDIVIDUAL

ASSIGNOR:  
TYLER, MARGARET

DOC DATE: 06/01/2018  
CITIZENSHIP: UNITED STATES  
ENTITY: INDIVIDUAL

ASSIGNEE:  
AIRIGAN SOLUTIONS, LLC  
  
107 JOHN STREET, SUITE 1-C  
SOUTHPORT, CONNECTICUT 06890

CITIZENSHIP: CONNECTICUT  
ENTITY: LIMITED LIABILITY COMPANY

SERIAL NUMBER: 86736673  
REGISTRATION NUMBER: 5142630  
MARK: NEGG  
DRAWING TYPE: STANDARD CHARACTER MARK

FILING DATE: 08/25/2015  
REGISTRATION DATE: 02/14/2017

6369/0707 PAGE 2

ASSIGNMENT RECORDATION BRANCH  
PUBLIC RECORDS DIVISION

# United States of America

United States Patent and Trademark Office

## Negg

**Reg. No. 5,142,630**

**Registered Feb. 14, 2017**

**Int. Cl.: 8**

**Trademark**

**Principal Register**

Sheila Torgan (UNITED STATES INDIVIDUAL)  
400 Congress Street  
Fairfield, CT 06824

Margaret Tyler (UNITED STATES INDIVIDUAL)  
105 Dunham Road  
Fairfield, CT 06824

CLASS 8: Manually operated device used for peeling eggs

FIRST USE 10-15-2015; IN COMMERCE 10-18-2015

THE MARK CONSISTS OF STANDARD CHARACTERS WITHOUT CLAIM TO ANY PARTICULAR FONT STYLE, SIZE OR COLOR

SER. NO. 86-736,673, FILED 08-25-2015  
JORDAN A BAKER, EXAMINING ATTORNEY



*Michelle K. Lee*

Director of the United States  
Patent and Trademark Office

**REQUIREMENTS TO MAINTAIN YOUR FEDERAL TRADEMARK REGISTRATION**

**WARNING: YOUR REGISTRATION WILL BE CANCELLED IF YOU DO NOT FILE THE DOCUMENTS BELOW DURING THE SPECIFIED TIME PERIODS.**

**Requirements in the First Ten Years\***

**What and When to File:**

- **First Filing Deadline:** You must file a Declaration of Use (or Excusable Nonuse) between the 5th and 6th years after the registration date. See 15 U.S.C. §§1058, 1141k. If the declaration is accepted, the registration will continue in force for the remainder of the ten-year period, calculated from the registration date, unless cancelled by an order of the Commissioner for Trademarks or a federal court.
- **Second Filing Deadline:** You must file a Declaration of Use (or Excusable Nonuse) and an Application for Renewal between the 9th and 10th years after the registration date.\* See 15 U.S.C. §1059.

**Requirements in Successive Ten-Year Periods\***

**What and When to File:**

- You must file a Declaration of Use (or Excusable Nonuse) and an Application for Renewal between every 9th and 10th-year period, calculated from the registration date.\*

**Grace Period Filings\***

The above documents will be accepted as timely if filed within six months after the deadlines listed above with the payment of an additional fee.

**\*ATTENTION MADRID PROTOCOL REGISTRANTS:** The holder of an international registration with an extension of protection to the United States under the Madrid Protocol must timely file the Declarations of Use (or Excusable Nonuse) referenced above directly with the United States Patent and Trademark Office (USPTO). The time periods for filing are based on the U.S. registration date (not the international registration date). The deadlines and grace periods for the Declarations of Use (or Excusable Nonuse) are identical to those for nationally issued registrations. See 15 U.S.C. §§1058, 1141k. However, owners of international registrations do not file renewal applications at the USPTO. Instead, the holder must file a renewal of the underlying international registration at the International Bureau of the World Intellectual Property Organization, under Article 7 of the Madrid Protocol, before the expiration of each ten-year term of protection, calculated from the date of the international registration. See 15 U.S.C. §1141j. For more information and renewal forms for the international registration, see <http://www.wipo.int/madrid/en/>.

**NOTE: Fees and requirements for maintaining registrations are subject to change. Please check the USPTO website for further information. With the exception of renewal applications for registered extensions of protection, you can file the registration maintenance documents referenced above online at <http://www.uspto.gov>.**

**NOTE: A courtesy e-mail reminder of USPTO maintenance filing deadlines will be sent to trademark owners/holders who authorize e-mail communication and maintain a current e-mail address with the USPTO. To ensure that e-mail is authorized and your address is current, please use the Trademark Electronic Application System (TEAS) Correspondence Address and Change of Owner Address Forms available at <http://www.uspto.gov>.**

**Complaint**

**EXHIBIT 2**

Easy, Fast  
& Fun!

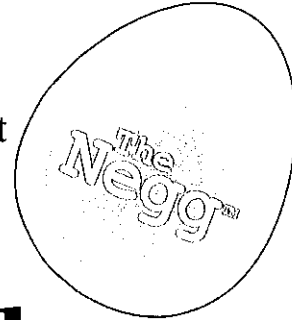

# egg peeler

Easy, Fast & Fun!

# egg peeler

**Simple to Use:**

**ADD** a little water and  
your boiled egg.

**SNAP** on the cap.

**SHAKE** up and down.

**SLIDE** off the shell.

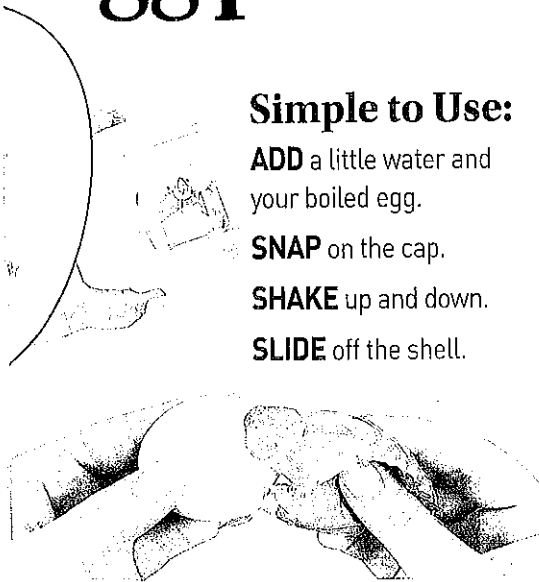

Easy, Fast & Fun!

# egg peeler

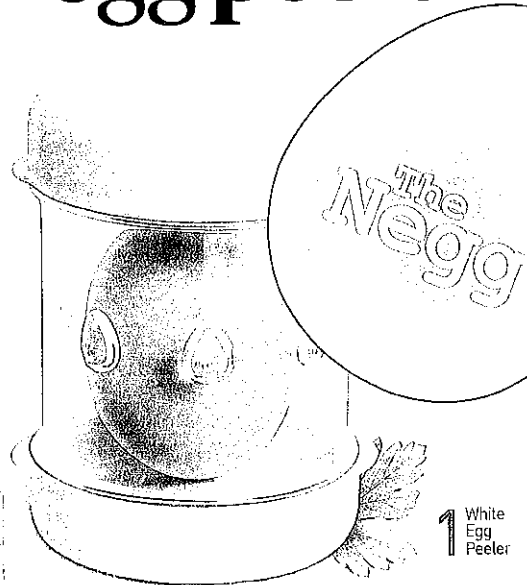

1 White  
Egg  
Peeler

Easy, Fast & Fun!  
**egg peeler**

If you like hard boiled eggs,  
The Negg™ is a kitchen essential.

- BPA Free
- Food Safe
- Dishwasher Safe
- Available in multiple colors

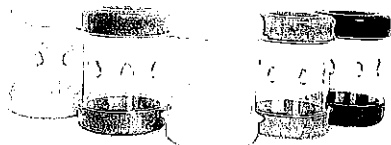

For tips, tricks and some great recipes,  
visit us at [www.neggmaker.com](http://www.neggmaker.com)

The NEGG™ is a trademark of Airigan Solutions, LLC  
Patent Pending  
©2017 Airigan Solutions, LLC  
Airigan Solutions, LLC, 107 John Street, Southington, CT 06489



Easy, Fast & Fun!  
**egg peeler**

The  
Negg



White  
Egg  
Peeler

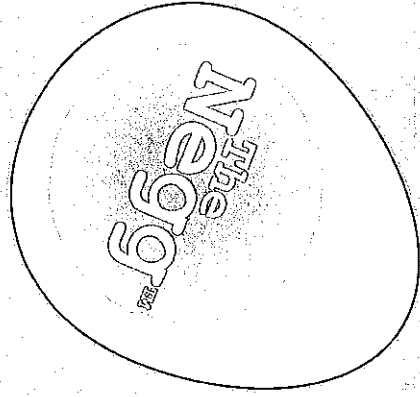

# egg peeler

Easy, Fast & Fun!

If you like hard boiled eggs **The Negg™** is a kitchen essential.

For tips, tricks and some great recipes, visit us

[www.neggmaker.com](http://www.neggmaker.com)

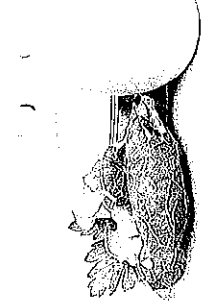
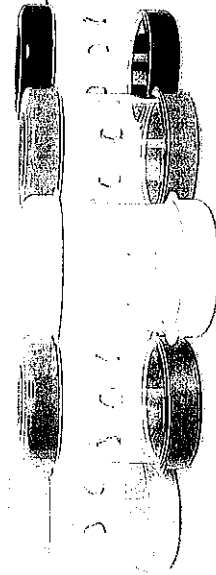
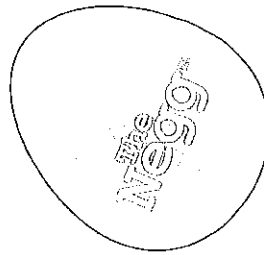

Aligen Solutions, LLC, 107 John Street, Southport, CT 06890. Questions? Call us! (203) 564-7781

Easy, Fast  
& Fun!

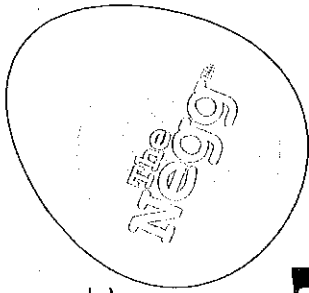

# egg peeler

- BPA Free
- Dishwasher Safe (top rack)
- Food Safe
- Available in multiple colors

## Simple to Use:

**ADD** a little water and your boiled egg.

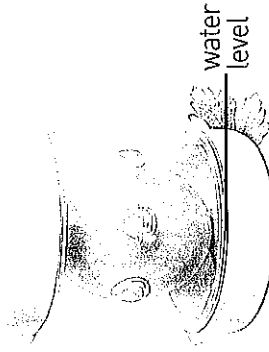

## The BEST Boiled Egg Recipe: Recommended by The Negg™

### Extra-Large Chicken Eggs

Bring a pot of water to a boil. Using a slotted spoon or ladle, carefully place your eggs in the boiling water.

When the water returns to a boil, cook the eggs for 12 minutes. Immediately remove the eggs from the hot water and place them in a bowl of ice water for 3 to 5 minutes before peeling.

**NOTE:**

As a general rule, adjust the cooking time by 1 minute—up or down—depending on the size of your eggs.

**SNAP** on the cap and **SHAKE** a few times!



**SLIDE** off the shell and **ENJOY!**



The shaking should be vigorous, enough to fracture the shell and membrane. Check after 4 or so shakes. You should feel the shell "soften". When you see the white visible, you're done!

NEGG™ is a registered trademark of Airigan Solutions, LLC  
Patent Pending ©2017 Airigan Solutions, LLC

UNITED STATES DISTRICT COURT  
SOUTHERN DISTRICT OF NEW YORK

-----X  
AIRIGAN SOLUTIONS, LLC, :  
 : Civil Action No.  
 :  
 Plaintiff, : 18-CV-6132 (GHW)  
 :  
 v. :  
 :  
 YIWU LANHOME JEWELRY CO., LTD., : Jury Trial Requested  
 et al., :  
 :  
 Defendants. :  
 :  
-----X

CHAMBER'S COPY

**PLAINTIFF'S PAPERS IN SUPPORT OF  
ORDER TO SHOW CAUSE WHY DEFAULT JUDGMENT AND  
PERMANENT INJUNCTION SHOULD NOT BE ENTERED  
AGAINST DEFAULTING DEFENDANTS**

February 6, 2019

Copy 2 of 2

**FERENCE & ASSOCIATES LLC**  
Stanley D. Ference III (SF1086)  
409 Broad Street  
Pittsburgh, Pennsylvania 15143  
Telephone: (412) 741-8400  
Facsimile: (412) 741-9292

Attorneys for Plaintiff

# Complaint

## EXHIBIT 3



UNITED STATES PATENT AND TRADEMARK OFFICE

UNDER SECRETARY OF COMMERCE FOR INTELLECTUAL PROPERTY AND  
DIRECTOR OF THE UNITED STATES PATENT AND TRADEMARK OFFICE

JULY 3, 2018

PTAS

FERENCE & ASSOCIATES LLC  
409 BROAD STREET  
PITTSBURGH, PA 15143

504987176

UNITED STATES PATENT AND TRADEMARK OFFICE  
NOTICE OF RECORDATION OF ASSIGNMENT DOCUMENT

THE ENCLOSED DOCUMENT HAS BEEN RECORDED BY THE ASSIGNMENT RECORDATION BRANCH OF THE U.S. PATENT AND TRADEMARK OFFICE. A COMPLETE COPY IS AVAILABLE AT THE ASSIGNMENT SEARCH ROOM ON THE REEL AND FRAME NUMBER REFERENCED BELOW.

PLEASE REVIEW ALL INFORMATION CONTAINED ON THIS NOTICE. THE INFORMATION CONTAINED ON THIS RECORDATION NOTICE REFLECTS THE DATA PRESENT IN THE PATENT AND TRADEMARK ASSIGNMENT SYSTEM. IF YOU SHOULD FIND ANY ERRORS OR HAVE QUESTIONS CONCERNING THIS NOTICE, YOU MAY CONTACT THE ASSIGNMENT RECORDATION BRANCH AT 571-272-3350. PLEASE SEND REQUEST FOR CORRECTION TO: U.S. PATENT AND TRADEMARK OFFICE, MAIL STOP: ASSIGNMENT RECORDATION BRANCH, P.O. BOX 1450, ALEXANDRIA, VA 22313.

RECORDATION DATE: 07/02/2018

REEL/FRAME: 046255/0183  
NUMBER OF PAGES: 2

BRIEF: ASSIGNMENT OF ASSIGNORS INTEREST (SEE DOCUMENT FOR DETAILS).

DOCKET NUMBER: 972.003

ASSIGNOR:

TYLER, MARGARET B.

DOC DATE: 06/01/2018

ASSIGNOR:

TORGAN, SHEILA M.

DOC DATE: 06/01/2018

ASSIGNEE:

AIRIGAN SOLUTIONS, LLC  
107 JOHN STREET  
SUITE 1-C  
SOUTHPORT, CONNECTICUT 06890

APPLICATION NUMBER: 15156785

PATENT NUMBER: 9968211

TITLE: PERSONAL EGG PEELER

FILING DATE: 05/17/2016

ISSUE DATE: 05/15/2018

ASSIGNMENT RECORDATION BRANCH  
PUBLIC RECORDS DIVISION



US009968211B2

(12) **United States Patent**  
Tyler

(10) **Patent No.:** US 9,968,211 B2  
(45) **Date of Patent:** May 15, 2018

(54) **PERSONAL EGG PEELER**

(56) **References Cited**

(71) Applicant: Margaret B Tyler, Fairfield, CT (US)  
(72) Inventor: Margaret B Tyler, Fairfield, CT (US)  
(\* ) Notice: Subject to any disclaimer, the term of this patent is extended or adjusted under 35 U.S.C. 154(b) by 165 days.

U.S. PATENT DOCUMENTS

1,030,324 A *	6/1912	Pender	.....	A47G 19/28
				30/120.1
2,962,067 A *	11/1960	Mesojedec	.....	A47G 19/28
				99/498
3,092,409 A *	6/1963	Murray	.....	A47G 19/28
				99/498
3,192,977 A *	7/1965	Bean	.....	A23N 7/01
				426/483
4,149,456 A	4/1979	Gisonni		
4,308,290 A	12/1981	Fujii		
5,573,803 A *	11/1996	Omessi	.....	A47J 17/02
				426/483
8,497,845 B2	7/2013	Braithwaite et al.		
2014/0004236 A1	1/2014	Braithwaite et al.		

(21) Appl. No.: 15/156,785

(22) Filed: May 17, 2016

(65) **Prior Publication Data**  
US 2016/0338515 A1 Nov. 24, 2016

\* cited by examiner  
*Primary Examiner* — Reginald L Alexander  
(74) *Attorney, Agent, or Firm* — John L. Sotomayor

**Related U.S. Application Data**

(60) Provisional application No. 62/163,062, filed on May 18, 2015.

(51) **Int. Cl.**  
A47G 19/28 (2006.01)

(52) **U.S. Cl.**  
CPC ..... A47G 19/28 (2013.01)

(58) **Field of Classification Search**  
CPC ..... A47G 19/28; A47J 43/14  
USPC ..... 99/568, 571, 577, 586, 587, 588  
See application file for complete search history.

(57) **ABSTRACT**

An apparatus is described that permits a user to quickly and effortlessly separate an egg shell from the body of a hard-boiled egg. The apparatus has a hollow body into which an egg is inserted, a convex shaped bottom section and a convex shaped top portion. Additionally, the interior surface of the hollow body has a number of protrusions that contribute to peeling action. Eggs are inserted into the apparatus, water is added, the apparatus is sealed, the user agitates the apparatus for a short time, and then pours out the separated egg and egg shell along with the water.

10 Claims, 5 Drawing Sheets

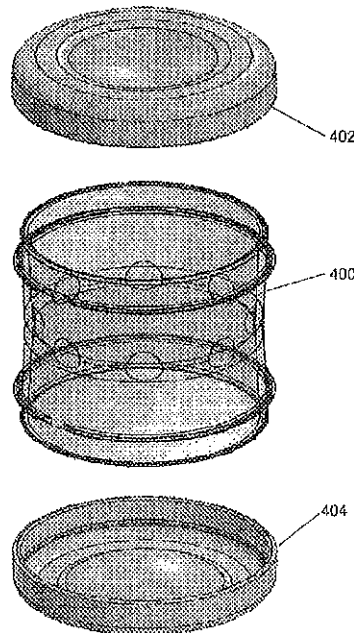

U.S. Patent

May 15, 2018

Sheet 1 of 5

US 9,968,211 B2

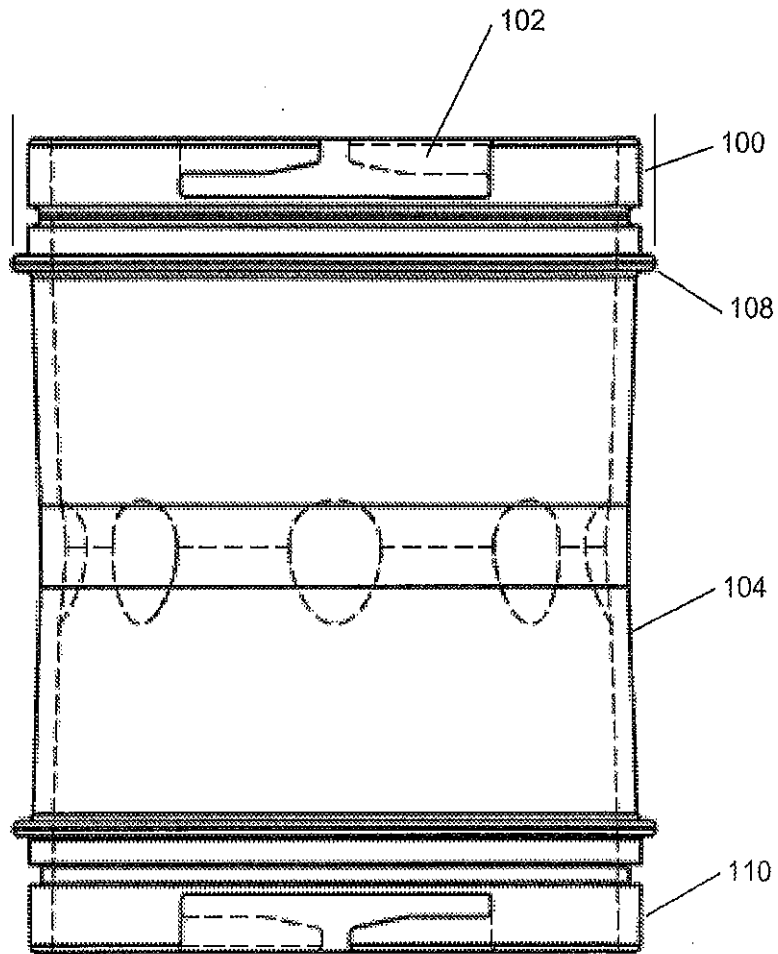

FIGURE 1

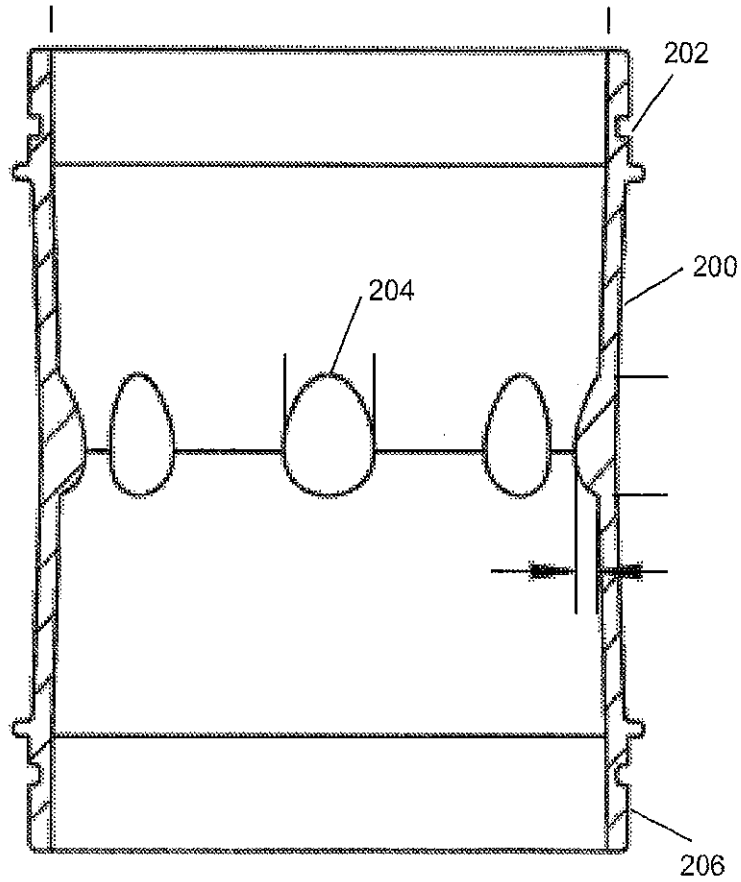

FIGURE 2

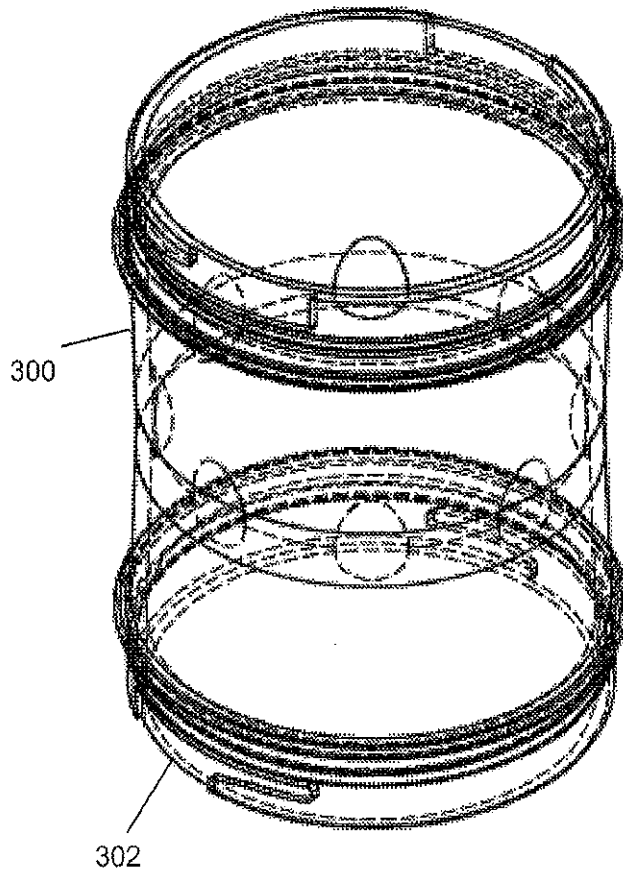

FIGURE 3

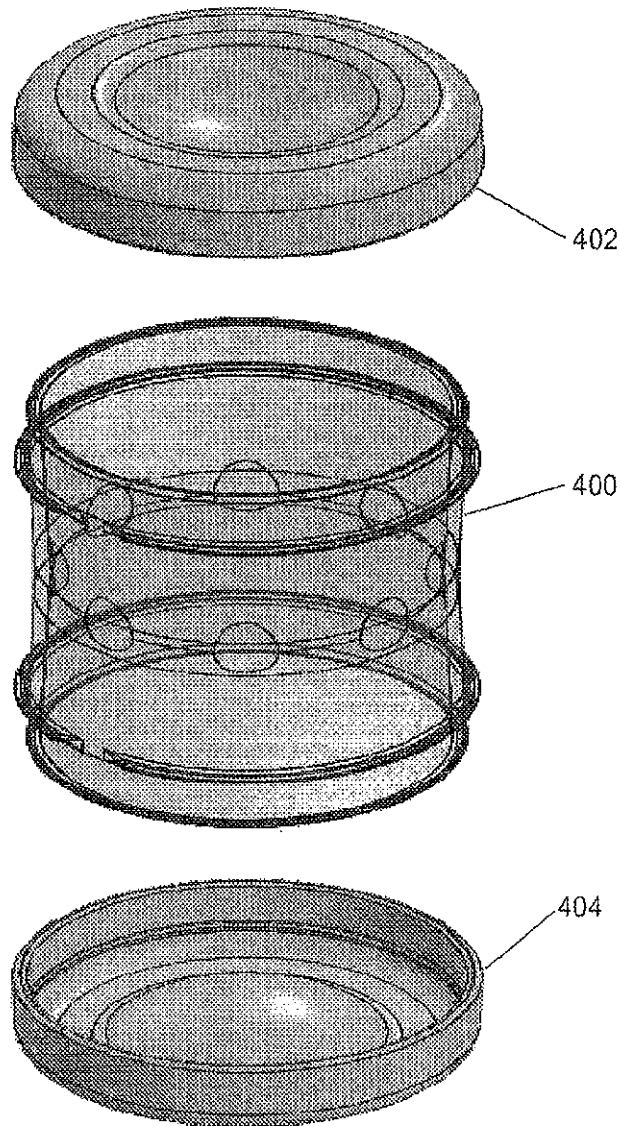

FIGURE 4

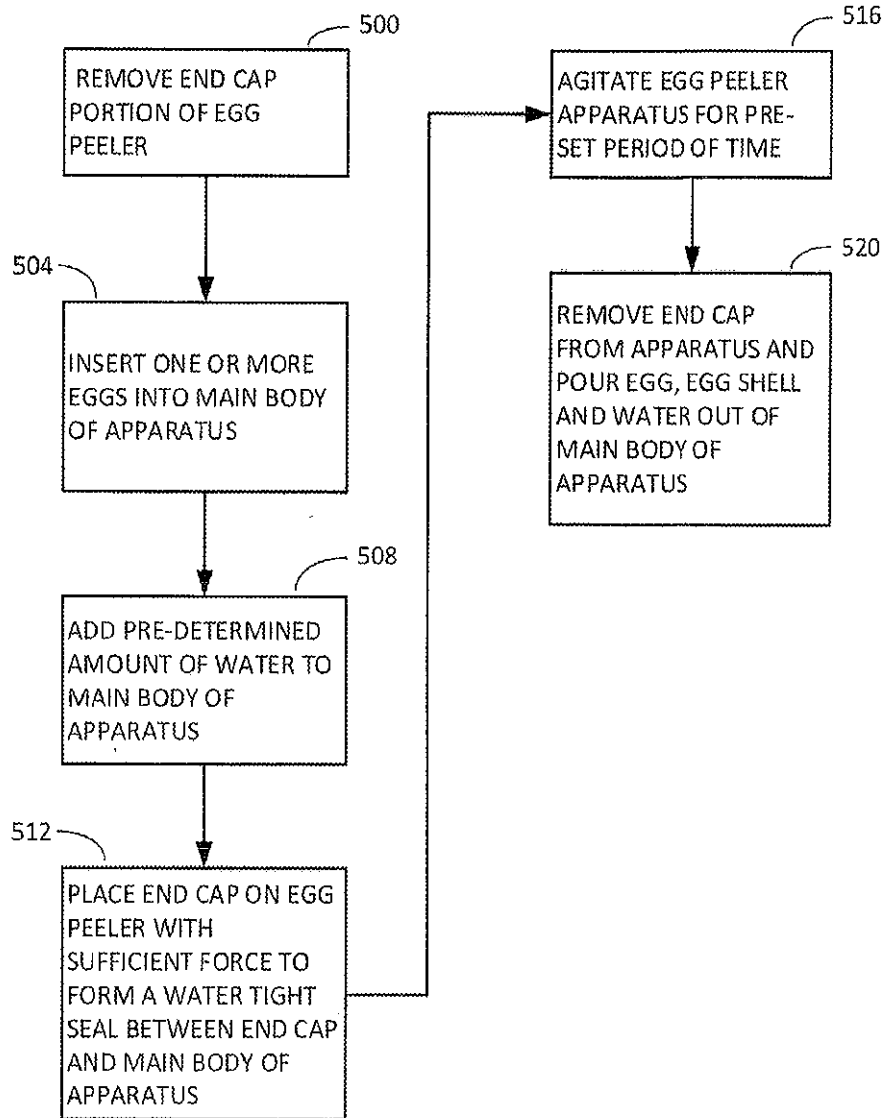

FIGURE 5

US 9,968,211 B2

1

**PERSONAL EGG PEELER****PRIORITY CLAIM**

This Non-Provisional application claims under 35 U.S.C. § 120, the benefit of priority to the Provisional Application 62/163,062, filed May 15, 2015, and Titled "Personal Egg Peeler" which is hereby incorporated by reference in its entirety.

**COPYRIGHT NOTICE**

A portion of the disclosure of this patent document contains material which is subject to copyright protection. The copyright owner has no objection to the facsimile reproduction of the patent document or the patent disclosure, as it appears in the Patent and Trademark Office patent file or records, but otherwise reserves all copyright rights whatsoever.

**BACKGROUND**

The present invention relates generally to food preparation, and specifically to preparing hard boiled eggs for consumption. Removing the shell of a hard-boiled egg is a tedious process, especially if there is little time prior to the consumption of the eggs. Commercial processes for removing the shell do not apply to home makers and other consumers of small numbers of eggs over a set period of time as the machines used are generally large, cumbersome, and expensive, although effective.

**BRIEF DESCRIPTION OF THE DRAWINGS**

Certain illustrative embodiments illustrating organization and method of operation, together with objects and advantages may be best understood by reference detailed description that follows taken in conjunction with the accompanying drawings in which:

FIG. 1 is a view of the exterior of a personal egg peeler apparatus consistent with certain embodiments of the present invention.

FIG. 2 is a view of the main body of a personal egg peeler apparatus consistent with certain embodiments of the present invention.

FIG. 3 is a view of a main body and end portion connectors of a personal egg peeler consistent with certain embodiments of the present invention.

FIG. 4 is a view of a main body and end portion connectors of a personal egg peeler in an exploded view consistent with certain embodiments of the present invention.

FIG. 5 is a flow diagram for the operation of a personal egg peeler consistent with certain embodiments of the present invention.

**DETAILED DESCRIPTION**

While this invention is susceptible of embodiment in many different forms, there is shown in the drawings and will herein be described in detail specific embodiments, with the understanding that the present disclosure of such embodiments is to be considered as an example of the principles and not intended to limit the invention to the specific embodiments shown and described. In the descrip-

2

tion below, like reference numerals are used to describe the same, similar or corresponding parts in the several views of the drawings.

The terms "a" or "an", as used herein, are defined as one or more than one. The term "plurality", as used herein, is defined as two or more than two. The term "another", as used herein, is defined as at least a second or more. The terms "including" and/or "having", as used herein, are defined as comprising (i.e., open language). The term "coupled", as used herein, is defined as connected, although not necessarily directly, and not necessarily mechanically.

Reference throughout this document to "one embodiment", "certain embodiments", "an embodiment" or similar terms means that a particular feature, structure, or characteristic described in connection with the embodiment is included in at least one embodiment of the present invention. Thus, the appearances of such phrases or in various places throughout this specification are not necessarily all referring to the same embodiment. Furthermore, the particular features, structures, or characteristics may be combined in any suitable manner in one or more embodiments without limitation.

A apparatus used for peeling commercial quantities of hard-boiled eggs, for use in such food items as egg-salad as an example, are often large, cumbersome, and expensive. The number of eggs to be peeled must, therefore, be quite large in order to justify the expense for such an apparatus.

Peeling more than a dozen, but less than a quantity that would justify the investment in a commercial size egg peeling apparatus, is a tedious, time-consuming task. However, peeling one, two, or a dozen hard-boiled eggs remains a tedious task, even though this process may not consume a large amount of time. There is a need for a personal egg peeler that removes the shell of a hard-boiled egg speedily and with little effort, while still remaining cost effective to purchase for a personal kitchen, or a low-volume commercial kitchen.

The egg peeler apparatus herein disclosed provides a low-cost, readily portable solution for the peeling of small quantities of hard-boiled eggs. The apparatus is configured to peel the eggs, separate the shell from the egg white, and perform this process in a very short time cycle. The apparatus consists of a cylindrical main body having convex end caps that are configured to be attached and removed from the cylindrical main body, and oval shaped protrusions extending from the interior surface of the cylindrical main body. The cylindrical main body is of sufficient diameter to permit the insertion of one or more eggs produced by a commercial variety hen. However, this should in no way be considered limiting as the cylindrical main body may be sized to accommodate eggs laid by other species of fowl as well.

The egg peeler has a top portion, also with a convex surface that faces the interior of the cylindrical main body, having a water tight connection and seal for sealing the apparatus when the top portion is connected to the main body. The convex end caps form the top and bottom portions of the apparatus when connected to the main body. Each end cap may have a water tight connection such as a gasket, an o-ring, a screw type fastener, or any other type of fastener that keeps water sealed inside the main body when the end caps are secured to the top and bottom portions of the main body. In operation, a user may remove the top portion of the egg peeler with the egg peeler oriented in a vertical plane, place one or more eggs of sufficient diameter to be fully enclosed by the main body of the egg peeler when inserted into the egg peeler, pour water sufficient to cover a third of the volume of the eggs when inserted into the main body,

US 9,968,211 B2

3

and replace the top convex end cap onto the top of the cylinder with sufficient force to cause the convex top portion to seal the main body of the cylinder so as to retain both the egg and the water within the main body of the egg peeler. The user then shakes the egg peeler apparatus for a predetermined time and removes one of the convex end cap portions, unsealing the egg peeler main body to permit removal of the separated egg and egg shell portions from the cylindrical main body of the apparatus.

Although particular exemplary embodiments of the innovation will be presented herein, it should be apparent that additional embodiments may be accessible to those of ordinary skill in the art without departing from the spirit of innovation of the recited embodiments.

Turning now to FIG. 1, consistent with certain embodiments of the invention this figure is a view of the personal egg peeler apparatus consistent with certain embodiments of the present invention. In this exemplary embodiment, a top portion 100 of a personal egg peeler apparatus is presented as having a substantially circular cross section. However, this should in no way be considered limiting as the top portion 100 may be manufactured in any shape that is consistent with the shape of the main body of the personal egg peeler and may be oval, square, rectangular or any other shape that permits the top portion 100 to be inserted into or onto the top of the main body 104 of the personal egg peeler. The top portion 100 may also have a convex shaped portion 102 so as to permit a user to insert a thumb or fingers into the convex shaped portion 102 to readily grasp the top portion 100 of the personal egg peeler when in use.

The top portion 100 may have a sealing element 108 that is configured to form a closure that permits a water tight seal when the top portion 100 is reattached to the main body 104 of the personal egg peeler. The sealing element may consist of clip fastening, gasket, screw type element, o-ring element, slide and lock connection, or any other fastening structure that permits the top element 100 to be attached to and removed from the main body 104 of the personal egg peeler while maintaining a water tight seal when the top portion 100 is fully secured to the main body 104. The top portion 100 may also be manufactured of a material such as rubber, plastic, silicon, acrylic, or any other equivalent material, that permits a water tight seal to be maintained when the top portion 100 is fully secured onto the top portion of the main body 104 of the personal egg peeler.

The bottom portion 110 of the personal egg peeler may also be convex in shape. The convex shaped portion 102 of both the top portion 100 and the bottom portion 110 permits each end portion to participate in the action by forming a grip for a user to firmly grasp the personal egg peeler when in use. As such, it is readily apparent that the convex shaped portion 102 is not the only shape in which the top portion 100 and the bottom portion 110 may be manufactured. Additional shapes that permit a firm grasp of the top portion 100 and the bottom portion 110 of the personal egg peeler, such as a flat surface with protrusions, a wavy surface, a central cone, or any other shaped indentation, are equally disclosed as being consistent with the purpose of the convex shaped portion 102 of the top portion 100 and the bottom portion 110 of the personal egg peeler.

Turning now to FIG. 2, consistent with certain embodiments of the invention is a view of the main body of a personal egg peeler apparatus consistent with certain embodiments of the present invention. In an exemplary embodiment, the main body 200 of the personal egg peeler may be configured in any shape that permits the complete enclosure of one or more eggs when the eggs are inserted

4

into the main body 200. The main body 200 may be manufactured of any material, such as glass, plastic, acrylic, or any other material that is water proof and has a hardness greater than the hardness of the shell of an egg to be inserted. In a non-limiting example, the main body 200 of the personal egg peeler is presented as a hollow cylinder. However, the main body 200 could equally well be manufactured as a hollow square, rectangular, oval, or other shape that would permit the complete insertion of one or more eggs into the hollow portion of the main body 200.

The inner surface of the main body 200 may have raised protrusions 204 that extend into the hollow space within the main body 200. The raised protrusions 204 may be manufactured as a seamless portion of the interior surface of main body 200, or they may be manufactured separately and later attached to the interior surface of the main body 200. In this exemplary embodiment, the raised protrusions 204 contribute to the action of peeling the one or more eggs inserted into the personal egg peeler.

In an exemplary embodiment, the top portion 100 and bottom portion 110 of the personal egg peeler may be manufactured as separable end portions of the personal egg peeler. A top connector portion 202 and a bottom connector portion 206 may be shaped to form a locking connection with the top portion 100 and bottom portion 110 when placed in contact with the main body 200 of the personal egg peeler.

When preparing to use the personal egg peeler, either the top portion 100 or the bottom portion 110 may be removed from contact with the main body 200. At this point, one or more eggs may be inserted into the main body 200 of the apparatus making the apparatus ready for use in removing the peel from a hard-boiled egg or eggs, depending upon the size and configuration of the apparatus. Water is placed in the cavity of the main body 200 to a level that is approximately one third of the volume of the interior of the main body 200. Alternatively, in another exemplary embodiment, a water level marker may be indicated on the exterior of the apparatus to provide a user with a guideline for the water level that is preferred when using the apparatus. The top portion 100 or bottom portion 110, whichever was removed to permit the insertion of the egg(s) and water, is placed fully in contact with the main body 200 so as to form a sealed, water tight container around the one or more inserted eggs. The user may then firmly grasp the personal egg peeler by the top and bottom convex, or other shaped, portions and operate the apparatus by shaking the personal egg peeler vigorously.

In this exemplary embodiment, the top portion 100 and the bottom portion 110 of the apparatus are fully removable to facilitate cleaning of the interior of the main body 200 of the personal egg peeler apparatus.

Turning now to FIG. 3, consistent with certain embodiments of the invention is a view of a main body and end portion connectors of a personal egg peeler consistent with certain embodiments of the present invention. In this exemplary embodiment, the main body 300 of the personal egg peeler may be connected to a top capping portion and a bottom capping portion (not shown) through the connection point 302 formed as a part of the main body 300 top and bottom sections. The connection point 302 may be formed as a locking channel that permits the insertion of a top cap or a bottom cap and forming a water tight seal as the top cap and/or bottom cap are turned to secure the top cap or bottom cap in the locking channel. It is understood that a locking channel is simply one implementation of the water tight seal between the end caps and the main body 300 of the appa-

US 9,968,211 B2

5

ratus. Additional sealing mechanisms that may form a water tight seal when fully engaged may include clip fasteners, gaskets, a screw type element, an o-ring element, slide and lock connection, or any other fastening structure that permits the end caps to be firmly attached to the main body 300 and forming a water tight seal.

Turning now to FIG. 4, consistent with certain embodiments of the invention is an exploded view of a main body and end portion connectors of a personal egg peeler consistent with certain embodiments of the present invention. In this exemplary view, the main body 400 of the personal egg peeler is a hollow structure that permits the insertion of one or more eggs into the hollow cavity forming the main body 400. Although the main body 400 is circular in cross section in this exemplary embodiment, this should in no way be considered limiting, as the main body 400 may be of any shape in cross section as long as the central portion of the main body has a cavity that accepts the insertion of one or more eggs in such as fashion as to permit the top end cap 402 and the bottom end cap 404 to be securely fastened to the main body 400 with the eggs fully inserted. The top end cap 402 and the bottom end cap 404 are configured to permit the end caps to be fastened to the top portion and the bottom portion of the main body 400, respectively, to form a water tight seal with the one or more eggs fully inserted into the main body 400.

Turning now to FIG. 5, consistent with certain embodiments of the invention is a flow diagram for the operation of a personal egg peeler consistent with certain embodiments of the present invention. In this exemplary embodiment, the action of peeling one or more eggs in the personal egg peeler begins at step 500 when a user removes an end cap, either the top portion or the bottom portion, of the personal egg peeler. At step 504, the user may place just one egg, or more than one egg, depending upon the size of the eggs relative to the hollow body section of the personal egg peeler. The user may only place the number of eggs into the personal egg peeler that will fit inside with sufficient clearance to permit the top of the personal egg peeler to be placed back into contact with the main body of the personal egg peeler so as to form a water tight seal, and will permit unrestrained movement of the egg, or eggs, inside the personal egg peeler.

At step 508, the user may add water to the main body of the personal egg peeler in sufficient quantity to fill a third of the interior of the main body, or sufficient water to rise to the indicator marking on the exterior surface of the main body of the personal egg peeler. At step 512, the user places the removed portion, whether the top portion or the bottom portion, of the personal egg peeler back into contact with the main body of the personal egg peeler. The placement of the removed portion of the egg peeler must be such that the top, or bottom, portion is in full contact along the entire extent of the gasket with the interior surface of the main body of the personal egg peeler, and put in place with sufficient force so as to form a water tight seal between the gasket part and the interior surface of the main body of the personal egg peeler.

At step 516, the user performs the egg peeling action by picking up the personal egg peeler and agitating the personal egg peeler in up and down, and circular motions for a pre-determined period of time. The pre-determined period of time may be approximately ten seconds, or may be adjusted based upon user experience or the number of eggs that have been inserted into the personal egg peeler to a greater or lesser extent to achieve a complete peeling action. At 520, the user, after agitating the personal egg peeler for the

6

pre-determined period of time, may remove the end cap portion of the personal egg peeler and pour out the separated egg and egg shell along with the water added earlier in the process. When completed, the top and bottom portions of the personal egg peeler may be removed to facilitate cleaning.

While certain illustrative embodiments have been described, it is evident that many alternatives, modifications, permutations and variations will become apparent to those skilled in the art in light of the foregoing description.

What is claimed is:

1. An egg peeler apparatus, comprising:

a container having a hollow main body and a top end cap and a bottom end cap;

the top end cap and bottom end cap having a convex shaped portion where said convex shaped portion is oriented such that the curved surface of each top and bottom end cap faces the interior of the cylindrical main body and forming the top and bottom portions of the container;

the interior surface of the container having a plurality of raised protrusions of sufficient height to extend into the hollow area of the hollow container;

the container main body having an internal dimension of sufficient diameter to permit the insertion of one or more standard size chicken eggs;

the apparatus configured to peel the one or more standard sized chicken eggs inserted into the hollow container when agitated by a user.

2. The apparatus of claim 1, where the main body of the container may have an external shape that is cylindrical, oval, square, rectangular, or any other regular shape.

3. The apparatus of claim 1, where the end caps form a water tight seal when securely fastened to the top and bottom portions of the main body of the container.

4. The apparatus of claim 1, where the raised protrusions are formed of the same material as the interior surface of the main body of the container.

5. The apparatus of claim 4, where the raised protrusions are shaped in an oval, rectangular, circular, square, or any other shape that is operative to form a protrusion against which an egg shell may impact.

6. The apparatus of claim 1, where the main body of the container is of sufficient dimension to be held in the hand of a user.

7. The apparatus of claim 1, where the top end cap and bottom end cap convex shape forms the center portion of the top end cap and bottom end cap, where the convex shape is of sufficient depth to permit a secure grip when held in the hand of the user.

8. The apparatus of claim 1, further comprising a fastening portion forming a portion of the top end cap and the bottom end cap where the fastening portion permits a user to remove the top end cap and the bottom end cap to remove any eggs and egg shells and to clean the interior of the main body of the container.

9. The apparatus of claim 1, where the interior volume of the main body of the container is sufficient to permit the insertion of as few as one or as many as three grade A large chicken eggs.

10. The apparatus of claim 1, where the agitation of the device is performed by the user for a predetermined time period of sufficient duration to crack and separate the shell from the egg or eggs inserted into the main body of the container.

\* \* \* \* \*

# **EXHIBIT 2**

**FERENCE & ASSOCIATES LLC**

Stanley D. Ference III (SF1086)  
409 Broad Street  
Pittsburgh, Pennsylvania 15143  
Telephone: (412) 741-8400  
Facsimile: (412) 741-9292

Attorneys for Plaintiff

UNITED STATES DISTRICT COURT  
SOUTHERN DISTRICT OF NEW YORK

-----X		
AIRIGAN SOLUTIONS, LLC,	:	Civil Action No.
	:	
Plaintiff,	:	18-cv-6132-GHW
	:	
v.	:	
	:	
YIWU LANHOME JEWELRY CO., LTD.,	:	Jury Trial Requested
et al.,	:	
	:	
Defendants.	:	<b><u>FILED UNDER SEAL</u></b>
	:	
-----X		

**CERTIFICATE OF SERVICE**

I, Brian Samuel Malkin, hereby certify as follows:

1. I am over eighteen (18) years of age and not a party to this action. I have never been convicted of a felony or any criminal offense involving moral turpitude, and I am fully competent to attest to the matters stated herein. I have personal knowledge of every statement made in this Certificate of Service and such statements are true and correct.

2. I am an attorney with the law firm of Ference & Associates LLC, which is located at 490 Broad Street, Pittsburgh, Pennsylvania 15143.

3. I am an attorney for the Plaintiff Airigan Solutions, LLC (“Airigan” or “Plaintiff”) in the above-captioned case.

4. On July 6, 2018, Plaintiff filed this action, and moved *ex parte* against all of the Defendants identified on the **Schedule “A”** attached to the Complaint for the following: 1) a temporary restraining order; 2) an order restraining assets and Merchant Storefronts,<sup>1</sup> 3) an order to show cause why a preliminary injunction should not issue; 4) an order authorizing alternative service; and 5) an order authorizing expedited discovery against all of the Defendants (“the Application”).

5. On July 19, 2018, Plaintiff filed an Amended Complaint seeking the same relief against all of the Defendants identified on the **Amended Schedule “A”** attached to the Amended Complaint and an Amended Summons was issued that applied to all of the Defendants.

6. On July 19, 2018, the Court entered an Order granting Plaintiff’s Application (the “TRO”).

7. In the TRO, the Court granted the Plaintiff’s request for an order authorizing alternative service by delivery of: PDF Copies of the TRO, together with the Amended Summons, Amended Complaint, and the related Papers and Orders via a link to a secure website (such as Dropbox.com, NutStore.com, a large mail link created through RPost.com and via website publication through a specific page dedicated to this Lawsuit accessible through ferencelaw.com) where each Defendant is able to download PDF copies of the TRO together with the Amended Summons, Amended Complaint, related orders, and all papers filed in support of and related to Plaintiff’s Application seeking the TRO. Service was to be made within five (5) days after the Financial Institutions and Third Party Service Providers complied with certain

---

<sup>1</sup> Where a defined term is referenced herein but not defined, it should be understood as it is defined in the Amended Complaint or Application.

provisions of the TRO and in no event later than ten (10) days from the date of the TRO. By Order dated July 27, 2018, the time for service was reset to within five (5) days after the Financial Institutions and Third Party Service Providers complied with certain provisions of the TRO

8. PayPal, Inc., and Context Logic, Inc., provided certain information required by the TRO on July 27, 2018 for certain Defendants and these Defendants were served on July 31, 2018. Amazon Payments, Inc., provided certain information required by the TRO on August 1, 2018 for certain Defendants and these Defendants were served on August 2, 2018. The Alibaba entities provided certain information required by the TRO on August 3, 2018 for certain Defendants and these Defendants were served the same day. Dunhuang Group provided certain information required by the TRO on July 24, 2018 for certain Defendants, but did not discuss the asset restraint. On July 31, 2018, Dunhuang Group responded to my inquiry about the asset restraint and these Defendants were served on August 3, 2018. Attached hereto is a Schedule showing all Defendants on Amended Schedule "A" and dates of service thereon.

9. Plaintiff has served all of the Defendants. The Amazon entities have not yet provided contact information for the Defendants selling on amazon.com; service on these Defendants was made using the messaging system provided on amazon.com. Service on all other Defendants was made using RPost using the email addresses already in our possession or provided by either the Financial Institutions or Third Party Service Providers.

I declare under the penalty of perjury laws of the United States of America that to the best of my knowledge the foregoing is true and correct.

Executed this 6th day of August, 2018, at Pittsburgh, Pennsylvania.

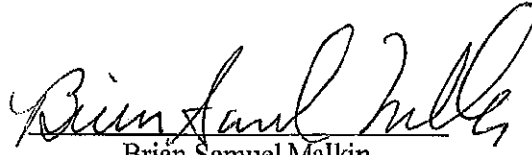
  
Brian Samuel Malkin

## DATES OF SERVICE FOR DEFENDANTS ON AMENDED SCHEDULE "A"

Def No.	Defendant by Seller ID	URL of Defendant's Merchant Storefront	ASIN/Prod ID/URL	Third Party Service Provider	Service Date
1	Yiwu Lanhome Jewelry Co., Ltd.	<a href="https://lanhome.en.alibaba.com/">https://lanhome.en.alibaba.com/</a>	<a href="http://www.alibaba.com/product-gs/60770761889/Hotting_Egg_Shell_Peelers_Peeling_Kitchen.html">http://www.alibaba.com/product-gs/60770761889/Hotting_Egg_Shell_Peelers_Peeling_Kitchen.html</a>	Alibaba.com	7/31/2018
2	Ningbo Mateyness Household Co., Ltd	<a href="https://mateyness.en.alibaba.com/">https://mateyness.en.alibaba.com/</a>	<a href="http://www.alibaba.com/product-gs/60767892976/Magic_Boiled_Egg_Peelers_Shell_Remover.html">http://www.alibaba.com/product-gs/60767892976/Magic_Boiled_Egg_Peelers_Shell_Remover.html</a>	Alibaba.com	7/31/2018
3	Jiangshan Topme Import & Export Co., Ltd.	<a href="https://jstuojin.en.alibaba.com/">https://jstuojin.en.alibaba.com/</a>	<a href="http://www.alibaba.com/product-gs/60744710801/Boiled_Egg_Shell_Peelers_Peeling_Kitchen.html">http://www.alibaba.com/product-gs/60744710801/Boiled_Egg_Shell_Peelers_Peeling_Kitchen.html</a>	Alibaba.com	7/31/2018
4	Yiwu Joyful Commodity Factory	<a href="https://vwiioful.en.alibaba.com/">https://vwiioful.en.alibaba.com/</a>	<a href="http://www.alibaba.com/product-gs/60755683587/Boiled_Egg_Stripper_Shell_Peelers_Peelers.html">http://www.alibaba.com/product-gs/60755683587/Boiled_Egg_Stripper_Shell_Peelers_Peelers.html</a>	Alibaba.com	7/31/2018
5	Huizhou Kangning Industrial Co., Ltd	<a href="https://kangningtd.en.alibaba.com/">https://kangningtd.en.alibaba.com/</a>	<a href="http://www.alibaba.com/product-gs/60756633069/Boiled_Egg_Peelers.html">http://www.alibaba.com/product-gs/60756633069/Boiled_Egg_Peelers.html</a>	Alibaba.com	7/31/2018
6	Ningbo Haishu Greenwell Commodity Industrial Co., Ltd.	<a href="https://nbgreenwell.en.alibaba.com/">https://nbgreenwell.en.alibaba.com/</a>	<a href="http://www.alibaba.com/product-gs/60765626122/Greenwell_hot_sale_egg_peeler_magic.html">http://www.alibaba.com/product-gs/60765626122/Greenwell_hot_sale_egg_peeler_magic.html</a>	Alibaba.com	7/31/2018
7	Hefei Fengzhisheng Trade Co., Ltd	<a href="https://hfzs.en.alibaba.com/">https://hfzs.en.alibaba.com/</a>	<a href="http://www.alibaba.com/product-gs/60751634037/Hot_Selling_Egg_Shell_Peelers_Stripper.html">http://www.alibaba.com/product-gs/60751634037/Hot_Selling_Egg_Shell_Peelers_Stripper.html</a>	Alibaba.com	7/31/2018
8	Ningbo Limkong International Trade Co	<a href="https://limkong.en.alibaba.com/">https://limkong.en.alibaba.com/</a>	<a href="https://www.alibaba.com/product-detail/Fun-Cooking-Gadgets-for-the-Family_60776409729.html">https://www.alibaba.com/product-detail/Fun-Cooking-Gadgets-for-the-Family_60776409729.html</a>	Alibaba.com	7/31/2018
9	Yiwu Aliyou Commodity Ltd.	<a href="https://youmall.en.alibaba.com/">https://youmall.en.alibaba.com/</a>	<a href="https://www.alibaba.com/product-detail/Boiled-Egg-Shell-Peelers-Peeling-Kitchen_60752731931.html">https://www.alibaba.com/product-detail/Boiled-Egg-Shell-Peelers-Peeling-Kitchen_60752731931.html</a>	Alibaba.com	7/31/2018
10	Ningbo Jiewei Kitchenware Co., Ltd.	<a href="https://jwkitchenware.en.alibaba.com/">https://jwkitchenware.en.alibaba.com/</a>	<a href="https://www.alibaba.com/product-detail/Customize-Egg-Peelers-Hard-Boiled-Egg_60754569548.html">https://www.alibaba.com/product-detail/Customize-Egg-Peelers-Hard-Boiled-Egg_60754569548.html</a>	Alibaba.com	7/31/2018
11	Ningbo Shenghui Plastic Technology Co., Ltd.	<a href="https://tech2005.en.alibaba.com/">https://tech2005.en.alibaba.com</a>	<a href="http://www.alibaba.com/product-gs/60755683587/Boiled_Egg_Stripper_Shell_Peelers_Peeling.html">http://www.alibaba.com/product-gs/60755683587/Boiled_Egg_Stripper_Shell_Peelers_Peeling.html</a>	Alibaba.com	7/31/2018
12	Shenzhen Vakind Technology Co., Ltd.	<a href="https://vakind.aliexpress.com/store/203288">https://vakind.aliexpress.com/store/203288</a>	<a href="http://www.aliexpress.com/item/Plastic-Egg-Shell-Peelers-Egg-Slicer-Cutter-Egg-Shell-Separator-Scissors-Peeling-Tool-Household-Kitchen-Cooking/32858171417.html">http://www.aliexpress.com/item/Plastic-Egg-Shell-Peelers-Egg-Slicer-Cutter-Egg-Shell-Separator-Scissors-Peeling-Tool-Household-Kitchen-Cooking/32858171417.html</a>	Aliexpress.com	8/3/2018
13	Pawprint Store	<a href="https://www.aliexpress.com/store/2675065">https://www.aliexpress.com/store/2675065</a>	<a href="http://www.aliexpress.com/item/2018-New-arrival-Egg-Shell-Peelers-Egg-Slicer-Cutter-Peeling-Tool-egg-Peelers-Kitchen-Tool-Home/32846925596.html">http://www.aliexpress.com/item/2018-New-arrival-Egg-Shell-Peelers-Egg-Slicer-Cutter-Peeling-Tool-egg-Peelers-Kitchen-Tool-Home/32846925596.html</a>	Aliexpress.com	8/3/2018

## DATES OF SERVICE FOR DEFENDANTS ON AMENDED SCHEDULE "A"

Def No.	Defendant by Seller ID	URL of Defendant's Merchant Storefront	ASIN/Prod ID/URL	Third Party Service Provider	Service Date
14	1st kitchen Store	<a href="https://www.aliexpress.com/store/3450001">https://www.aliexpress.com/store/3450001</a>	<a href="http://www.aliexpress.com/item/VYSHION-Egg-Shell-Peelers-Slicer-Remover-Dividers-Plastic-Egg-Scissor-Cutter-Handle-Egg-Tools-Drop-Shipping/32857952797.html">http://www.aliexpress.com/item/VYSHION-Egg-Shell-Peelers-Slicer-Remover-Dividers-Plastic-Egg-Scissor-Cutter-Handle-Egg-Tools-Drop-Shipping/32857952797.html</a>	Aliexpress.com	8/3/2018
15	Good Lifestyle Store	<a href="https://www.aliexpress.com/store/2496049">https://www.aliexpress.com/store/2496049</a>	<a href="http://www.aliexpress.com/item/Egg-Shell-Peeler-Egg-Slicer-Cutter-Kitchen-Peeling-Tool-Egg-Peeler-for-Home-Kitchen-Accessories-Egg/32852766486.html">http://www.aliexpress.com/item/Egg-Shell-Peeler-Egg-Slicer-Cutter-Kitchen-Peeling-Tool-Egg-Peeler-for-Home-Kitchen-Accessories-Egg/32852766486.html</a>	Aliexpress.com	8/3/2018
16	Hinta Dropshipping Store	<a href="https://www.aliexpress.com/store/3155043">https://www.aliexpress.com/store/3155043</a>	<a href="http://www.aliexpress.com/item/Creative-Cooked-Egg-Peeler-Hard-Boiled-Egg-Shell-Peeler-Peeling-Kitchen-Tool/32860312736.html">http://www.aliexpress.com/item/Creative-Cooked-Egg-Peeler-Hard-Boiled-Egg-Shell-Peeler-Peeling-Kitchen-Tool/32860312736.html</a>	Aliexpress.com	8/3/2018
17	WholeWorld Store	<a href="https://www.aliexpress.com/store/1463728">https://www.aliexpress.com/store/1463728</a>	<a href="http://www.aliexpress.com/item/Cooked-Egg-Peeler-Hard-Boiled-Egg-Shell-Peelers-Peeling-Kitchen-Tool-Home-egg-slicer/32858078185.html">http://www.aliexpress.com/item/Cooked-Egg-Peeler-Hard-Boiled-Egg-Shell-Peelers-Peeling-Kitchen-Tool-Home-egg-slicer/32858078185.html</a>	Aliexpress.com	8/3/2018
18	StarStar Store	<a href="https://believe.aliexpress.com/store/2784019">https://believe.aliexpress.com/store/2784019</a>	<a href="http://www.aliexpress.com/item/Cooked-Egg-Peeler-Hard-Boiled-Egg-Shell-Peelers-Peeling-Kitchen-Tool-Home-egg-slicer/32857902336.html">http://www.aliexpress.com/item/Cooked-Egg-Peeler-Hard-Boiled-Egg-Shell-Peelers-Peeling-Kitchen-Tool-Home-egg-slicer/32857902336.html</a>	Aliexpress.com	8/3/2018
19	CCTX Store	<a href="https://www.aliexpress.com/store/3363024">https://www.aliexpress.com/store/3363024</a>	<a href="http://www.aliexpress.com/item/2018-Cooked-Egg-Peeler-Hard-Boiled-Egg-Shell-Peeler-Peeling-Kitchen-Tool-AP6/32860921958.html">http://www.aliexpress.com/item/2018-Cooked-Egg-Peeler-Hard-Boiled-Egg-Shell-Peeler-Peeling-Kitchen-Tool-AP6/32860921958.html</a>	Aliexpress.com	8/3/2018
20	MUQGEW Pets Store	<a href="https://www.aliexpress.com/store/3243081">https://www.aliexpress.com/store/3243081</a>	<a href="http://www.aliexpress.com/item/Cooked-Egg-Peeler-Hard-whisk-Boiled-Egg-Shell-poached-Peeling-Kitchen-Tool-shape-for-egg-cutter/32857081274.html">http://www.aliexpress.com/item/Cooked-Egg-Peeler-Hard-whisk-Boiled-Egg-Shell-poached-Peeling-Kitchen-Tool-shape-for-egg-cutter/32857081274.html</a>	Aliexpress.com	8/3/2018
21	KitchenMall Store	<a href="https://www.aliexpress.com/store/3402012">https://www.aliexpress.com/store/3402012</a>	<a href="http://www.aliexpress.com/item/New-Arrival-Egg-Shell-Peeler-Egg-Slicer-Cutter-Kitchen-Peeling-Tool-Egg-Peeler-For-Home-Kitchen/32854213530.html">http://www.aliexpress.com/item/New-Arrival-Egg-Shell-Peeler-Egg-Slicer-Cutter-Kitchen-Peeling-Tool-Egg-Peeler-For-Home-Kitchen/32854213530.html</a>	Aliexpress.com	8/3/2018
22	Me&My House China Textile Retail Store	<a href="https://www.aliexpress.com/store/2227092">https://www.aliexpress.com/store/2227092</a>	<a href="http://www.aliexpress.com/item/Peeler-Cooked-Egg-Peeler-Hard-Hard-Boiled-Egg-Shell-Peeler-Peeling-Kitchen-Kitchen-Tool-Drop-Shipping/32859923071.html">http://www.aliexpress.com/item/Peeler-Cooked-Egg-Peeler-Hard-Hard-Boiled-Egg-Shell-Peeler-Peeling-Kitchen-Kitchen-Tool-Drop-Shipping/32859923071.html</a>	Aliexpress.com	8/3/2018
23	punkgirl store	<a href="https://www.aliexpress.com/store/1191437">https://www.aliexpress.com/store/1191437</a>	<a href="http://www.aliexpress.com/item/Egg-Peeler-Shell-Peeling-Machine-Hard-Boiled-Convenient-Kitchen-Paring-Tool-TB-Sale/32882869849.html">http://www.aliexpress.com/item/Egg-Peeler-Shell-Peeling-Machine-Hard-Boiled-Convenient-Kitchen-Paring-Tool-TB-Sale/32882869849.html</a>	Aliexpress.com	8/3/2018
24	Umaru's Houseware Store	<a href="https://www.aliexpress.com/store/2400091">https://www.aliexpress.com/store/2400091</a>	<a href="http://www.aliexpress.com/item/2018-New-Arrival-Egg-Shell-Peeler-Egg-Slicer-Cutter-Peeling-Tool-Hard-Boiled-Egg-Peeler-Kitchen/32872366542.html">http://www.aliexpress.com/item/2018-New-Arrival-Egg-Shell-Peeler-Egg-Slicer-Cutter-Peeling-Tool-Hard-Boiled-Egg-Peeler-Kitchen/32872366542.html</a>	Aliexpress.com	8/3/2018
25	Fantasy Garden & Life House Store	<a href="https://www.aliexpress.com/store/2802127">https://www.aliexpress.com/store/2802127</a>	<a href="http://www.aliexpress.com/item/Egg-Shell-Peeler-Egg-Slicer-Cutter-Peeling-Tool-Boiled-Egg-Peeler-Home-Egg-Slicer-Kitchen-Gadgets/32866539668.html">http://www.aliexpress.com/item/Egg-Shell-Peeler-Egg-Slicer-Cutter-Peeling-Tool-Boiled-Egg-Peeler-Home-Egg-Slicer-Kitchen-Gadgets/32866539668.html</a>	Aliexpress.com	8/3/2018

## DATES OF SERVICE FOR DEFENDANTS ON AMENDED SCHEDULE "A"

Def No.	Defendant by Seller ID	URL of Defendant's Merchant Storefront	ASIN/Prod ID/URL	Third Party Service Provider	Service Date
26	My House Store Store	<a href="https://www.aliexpress.com/store/2948247">https://www.aliexpress.com/store/2948247</a>	<a href="http://www.aliexpress.com/item/Egg-Tool-Cooked-Egg-Peeler-Hard-Kitchen-Tool-Boiled-Egg-Shell-Peeler-Peeling-Cooking-Tools-18MAR23/32859694732.html">http://www.aliexpress.com/item/Egg-Tool-Cooked-Egg-Peeler-Hard-Kitchen-Tool-Boiled-Egg-Shell-Peeler-Peeling-Cooking-Tools-18MAR23/32859694732.html</a>	Aliexpress.com	8/3/2018
27	Brunch Lifestyle Store	<a href="https://www.aliexpress.com/store/3239033">https://www.aliexpress.com/store/3239033</a>	<a href="http://www.aliexpress.com/item/2018-New-Arrival-Egg-Shell-Peeler-Plastic-Creative-Egg-Slicer-Cutter-Peeling-Tool-Egg-Peeler-Kitchen/32858119756.html">http://www.aliexpress.com/item/2018-New-Arrival-Egg-Shell-Peeler-Plastic-Creative-Egg-Slicer-Cutter-Peeling-Tool-Egg-Peeler-Kitchen/32858119756.html</a>	Aliexpress.com	8/3/2018
28	Transhome Dropshipping Kitchen Store	<a href="https://www.aliexpress.com/store/1713132">https://www.aliexpress.com/store/1713132</a>	<a href="http://www.aliexpress.com/item/Transhome-1Pcs-Negg-Egg-Peeler-Scissors-Slicers-Dividers-Egg-Tools-Kitchen-Gadgets-Accessories-Drop-Shipping/32852209033.html">http://www.aliexpress.com/item/Transhome-1Pcs-Negg-Egg-Peeler-Scissors-Slicers-Dividers-Egg-Tools-Kitchen-Gadgets-Accessories-Drop-Shipping/32852209033.html</a>	Aliexpress.com	8/3/2018
29	Believer Store	<a href="https://www.aliexpress.com/store/3676003">https://www.aliexpress.com/store/3676003</a>	<a href="http://www.aliexpress.com/item/1pcs-Negg-Egg-Peeler-Scissors-Slicers-Dividers-Egg-Tools-Kitchen-Gadgets-Accessories-Drop-Shipping/32868876371.html">http://www.aliexpress.com/item/1pcs-Negg-Egg-Peeler-Scissors-Slicers-Dividers-Egg-Tools-Kitchen-Gadgets-Accessories-Drop-Shipping/32868876371.html</a>	Aliexpress.com	8/3/2018
30	JOY HOME Mall	<a href="https://www.aliexpress.com/store/1997038">https://www.aliexpress.com/store/1997038</a>	<a href="http://www.aliexpress.com/item/Negg-Egg-Shell-Peeler-Kitchen-Tool-Home-Egg-Peeling-Tool/32856628180.html">http://www.aliexpress.com/item/Negg-Egg-Shell-Peeler-Kitchen-Tool-Home-Egg-Peeling-Tool/32856628180.html</a>	Aliexpress.com	8/3/2018
31	MIAONY Store	<a href="https://www.aliexpress.com/store/2885134">https://www.aliexpress.com/store/2885134</a>	<a href="http://www.aliexpress.com/item/1pcs-Negg-Egg-Peeler-Scissors-Slicers-Dividers-Egg-Tools-Kitchen-Gadgets-Accessories-Drop-Shipping/32871422984.html">http://www.aliexpress.com/item/1pcs-Negg-Egg-Peeler-Scissors-Slicers-Dividers-Egg-Tools-Kitchen-Gadgets-Accessories-Drop-Shipping/32871422984.html</a>	Aliexpress.com	8/3/2018
32	Dropship Hotsale Store	<a href="https://www.aliexpress.com/store/3617125">https://www.aliexpress.com/store/3617125</a>	<a href="http://www.aliexpress.com/item/Dropshipping-New-Clever-Negg-Boiled-Egg-Peeler-Magic-Egg-Sheller-Dividers-Eggshell-Separator-Peeling-Kitchen-Gadget/32867913687.html">http://www.aliexpress.com/item/Dropshipping-New-Clever-Negg-Boiled-Egg-Peeler-Magic-Egg-Sheller-Dividers-Eggshell-Separator-Peeling-Kitchen-Gadget/32867913687.html</a>	Aliexpress.com	8/3/2018
33	Hallelujah	<a href="https://www.aliexpress.com/store/326030">https://www.aliexpress.com/store/326030</a>	<a href="http://www.aliexpress.com/item/200pcs-New-Arrival-Negg-Egg-Shell-Peeler-Kitchen-Tool-Home-Egg-Peeling-Tools-egg-scissors-/32863710267.html">http://www.aliexpress.com/item/200pcs-New-Arrival-Negg-Egg-Shell-Peeler-Kitchen-Tool-Home-Egg-Peeling-Tools-egg-scissors-/32863710267.html</a>	Aliexpress.com	8/3/2018
34	Shanghai Jenny	<a href="https://www.aliexpress.com/store/1971468">https://www.aliexpress.com/store/1971468</a>	<a href="http://www.aliexpress.com/item/1pcs-Negg-Egg-Peeler-Scissors-Slicers-Dividers-Egg-Tools-Kitchen-Gadgets-Accessories-Drop-Shipping/32871470424.html">http://www.aliexpress.com/item/1pcs-Negg-Egg-Peeler-Scissors-Slicers-Dividers-Egg-Tools-Kitchen-Gadgets-Accessories-Drop-Shipping/32871470424.html</a>	Aliexpress.com	8/3/2018
35	FL YXF Store	<a href="https://www.aliexpress.com/store/4033097">https://www.aliexpress.com/store/4033097</a>	<a href="http://www.aliexpress.com/item/1pcs-Negg-Egg-Peeler-Scissors-Slicers-Dividers-Egg-Tools-Kitchen-Gadgets-Accessories-Drop-Shipping/32883983270.html">http://www.aliexpress.com/item/1pcs-Negg-Egg-Peeler-Scissors-Slicers-Dividers-Egg-Tools-Kitchen-Gadgets-Accessories-Drop-Shipping/32883983270.html</a>	Aliexpress.com	8/3/2018
36	Getyoursave	<a href="https://www.aliexpress.com/store/1491004">https://www.aliexpress.com/store/1491004</a>	<a href="http://www.aliexpress.com/item/1pcs-Negg-Egg-Peeler-Scissors-Slicers-Dividers-Egg-Tools-Kitchen-Gadgets-Accessories-Drop-Shipping/32871454519.html">http://www.aliexpress.com/item/1pcs-Negg-Egg-Peeler-Scissors-Slicers-Dividers-Egg-Tools-Kitchen-Gadgets-Accessories-Drop-Shipping/32871454519.html</a>	Aliexpress.com	8/3/2018
37	My SweetHome Store	<a href="https://www.aliexpress.com/store/1656297">https://www.aliexpress.com/store/1656297</a>	<a href="http://www.aliexpress.com/item/Egg-Shell-Peeler-Peeling-Tool-Boiled-Egg-Peeler-for-Kitchen-Egg-Boiled-Egg-Peeler/32871670399.html">http://www.aliexpress.com/item/Egg-Shell-Peeler-Peeling-Tool-Boiled-Egg-Peeler-for-Kitchen-Egg-Boiled-Egg-Peeler/32871670399.html</a>	Aliexpress.com	8/3/2018
38	Lucky Yune Store	<a href="https://www.aliexpress.com/store/3659035">https://www.aliexpress.com/store/3659035</a>	<a href="http://www.aliexpress.com/item/THE-NEGG-BOILED-EGG-PEELER/3285987697.html">http://www.aliexpress.com/item/THE-NEGG-BOILED-EGG-PEELER/3285987697.html</a>	Aliexpress.com	8/3/2018

## DATES OF SERVICE FOR DEFENDANTS ON AMENDED SCHEDULE "A"

Def No.	Defendant by Seller ID	URL of Defendant's Merchant Storefront	ASIN/Prod ID/URL	Third Party Service Provider	Service Date
39	Transhome Dropshipping Kitchen Store	<a href="https://www.aliexpress.com/store/1713132">https://www.aliexpress.com/store/1713132</a>	<a href="https://www.aliexpress.com/item/Transhome-10-Seconds-Egg-Stripper-Negg-Egg-Peeler-The-Goods-For-Kitchen-Dropshipping-Wholesalers-Bestsellers/32865657523.html">https://www.aliexpress.com/item/Transhome-10-Seconds-Egg-Stripper-Negg-Egg-Peeler-The-Goods-For-Kitchen-Dropshipping-Wholesalers-Bestsellers/32865657523.html</a>	Aliexpress.com	8/3/2018
40	Miss U Store	<a href="https://www.aliexpress.com/store/4086007">https://www.aliexpress.com/store/4086007</a>	<a href="https://www.aliexpress.com/item/10-Seconds-Egg-Stripper-Negg-Egg-Peeler-The-Goods-For-Kitchen-Dropshipping-Wholesalers-Bestsellers/100005839719.html">https://www.aliexpress.com/item/10-Seconds-Egg-Stripper-Negg-Egg-Peeler-The-Goods-For-Kitchen-Dropshipping-Wholesalers-Bestsellers/100005839719.html</a>	Aliexpress.com	8/3/2018
41	Homey Kitchen Store	<a href="https://www.aliexpress.com/store/2784165">https://www.aliexpress.com/store/2784165</a>	<a href="https://www.aliexpress.com/item/BOILED-EGG-PEELER-Egg-Shell-Peeler-Egg-Scissors-Slicers-Dividers-Cutter-Peeling-Tool-for-Home-Kitchen/32874051082.html">https://www.aliexpress.com/item/BOILED-EGG-PEELER-Egg-Shell-Peeler-Egg-Scissors-Slicers-Dividers-Cutter-Peeling-Tool-for-Home-Kitchen/32874051082.html</a>	Aliexpress.com	8/3/2018
42	Warm Harbor Store	<a href="https://www.aliexpress.com/store/3204007">https://www.aliexpress.com/store/3204007</a>	<a href="https://www.aliexpress.com/item/HOT-Egg-Shell-Peeler-Egg-Slicer-Cutter-Peeling-Tool-egg-Peeler-Kitchen-Tool-Home-Egg-Slicer/328604093350.html">https://www.aliexpress.com/item/HOT-Egg-Shell-Peeler-Egg-Slicer-Cutter-Peeling-Tool-egg-Peeler-Kitchen-Tool-Home-Egg-Slicer/328604093350.html</a>	Aliexpress.com	8/3/2018
43	Leading your life Store	<a href="https://www.aliexpress.com/store/2937009">https://www.aliexpress.com/store/2937009</a>	<a href="https://www.aliexpress.com/item/Egg-Shell-Peeler-Egg-Slicer-Cutter-Peeling-Tool-Boiled-Egg-Peeler-Home-Egg-Slicer-Kitchen-Gadgets/32862704199.html">https://www.aliexpress.com/item/Egg-Shell-Peeler-Egg-Slicer-Cutter-Peeling-Tool-Boiled-Egg-Peeler-Home-Egg-Slicer-Kitchen-Gadgets/32862704199.html</a>	Aliexpress.com	8/3/2018
44	Practical Kitchen Store	<a href="https://www.aliexpress.com/store/3111053">https://www.aliexpress.com/store/3111053</a>	<a href="https://www.aliexpress.com/item/Egg-Shell-Peeler-Egg-Slicer-Cutter-Peeling-Tool-Boiled-Egg-Peeler-Home-Egg-Slicer-Kitchen-Gadgets/32872427379.html">https://www.aliexpress.com/item/Egg-Shell-Peeler-Egg-Slicer-Cutter-Peeling-Tool-Boiled-Egg-Peeler-Home-Egg-Slicer-Kitchen-Gadgets/32872427379.html</a>	Aliexpress.com	8/3/2018
45	KIngPet Market Store	<a href="https://www.aliexpress.com/store/2881374">https://www.aliexpress.com/store/2881374</a>	<a href="https://www.aliexpress.com/item/Egg-Shell-Peeler-Egg-Slicer-Cutter-Peeling-Tool-Boiled-Egg-Peeler-Home-Egg-Slicer-Kitchen-Gadgets/32874321909.html">https://www.aliexpress.com/item/Egg-Shell-Peeler-Egg-Slicer-Cutter-Peeling-Tool-Boiled-Egg-Peeler-Home-Egg-Slicer-Kitchen-Gadgets/32874321909.html</a>	Aliexpress.com	8/3/2018
46	GeHe Store	<a href="https://gehe.aliexpress.com/store/1543548">https://gehe.aliexpress.com/store/1543548</a>	<a href="https://www.aliexpress.com/item/GOONBO-1-PC-Egg-Peeler-Plastic-Egg-Shell-Peeler-Egg-Slicer-Cutter-Peeling-Tool-Dropshipping/32868928327.html">https://www.aliexpress.com/item/GOONBO-1-PC-Egg-Peeler-Plastic-Egg-Shell-Peeler-Egg-Slicer-Cutter-Peeling-Tool-Dropshipping/32868928327.html</a>	Aliexpress.com	8/3/2018
47	Your assistant Store	<a href="https://www.aliexpress.com/store/3862025">https://www.aliexpress.com/store/3862025</a>	<a href="https://www.aliexpress.com/item/2018-New-arrival-Egg-Shell-Peeler-Egg-Slicer-Cutter-Peeling-Tool-egg-Peeler-Kitchen-Tool-Home/32875592879.html">https://www.aliexpress.com/item/2018-New-arrival-Egg-Shell-Peeler-Egg-Slicer-Cutter-Peeling-Tool-egg-Peeler-Kitchen-Tool-Home/32875592879.html</a>	Aliexpress.com	8/3/2018
48	WOWCC Dropshipping Store	<a href="https://www.aliexpress.com/store/1232637">https://www.aliexpress.com/store/1232637</a>	<a href="https://www.aliexpress.com/item/WOWCC-Egg-Shell-Peeler-Egg-Slicer-Cutter-Peeling-Tool-Egg-Peeler-Kitchen-Tool-Home-Egg-Slicer/32854360787.html">https://www.aliexpress.com/item/WOWCC-Egg-Shell-Peeler-Egg-Slicer-Cutter-Peeling-Tool-Egg-Peeler-Kitchen-Tool-Home-Egg-Slicer/32854360787.html</a>	Aliexpress.com	8/3/2018
49	AmyHome Store Store	<a href="https://www.aliexpress.com/store/2662193">https://www.aliexpress.com/store/2662193</a>	<a href="https://www.aliexpress.com/item/Plastic-Egg-Shell-Peeler-Egg-Slicer-Cutter-Egg-Shell-Separator-Scissors-Peeling-Tool-Household-Kitchen-Cooking/32876281402.html">https://www.aliexpress.com/item/Plastic-Egg-Shell-Peeler-Egg-Slicer-Cutter-Egg-Shell-Separator-Scissors-Peeling-Tool-Household-Kitchen-Cooking/32876281402.html</a>	Aliexpress.com	8/3/2018
50	Common Truth	<a href="https://tr.aliexpress.com/store/1380874">https://tr.aliexpress.com/store/1380874</a>	<a href="https://www.aliexpress.com/item/Household-Egg-Shell-Peeler-Egg-Slicer-Cutter-Egg-Shell-Separator-Scissors-Peeling-Tool-Plastic-Kitchen-Cooking/32858167464.html">https://www.aliexpress.com/item/Household-Egg-Shell-Peeler-Egg-Slicer-Cutter-Egg-Shell-Separator-Scissors-Peeling-Tool-Plastic-Kitchen-Cooking/32858167464.html</a>	Aliexpress.com	8/3/2018
51	VDHJUK Store	<a href="https://tr.aliexpress.com/store/2970028">https://tr.aliexpress.com/store/2970028</a>	<a href="https://www.aliexpress.com/item/2018-New-Egg-Shell-Peeler-Kitchen-Egg-Cutter-Tool-Home-Egg-Slicer-Scissors-Dividers/32857183442.html">https://www.aliexpress.com/item/2018-New-Egg-Shell-Peeler-Kitchen-Egg-Cutter-Tool-Home-Egg-Slicer-Scissors-Dividers/32857183442.html</a>	Aliexpress.com	8/3/2018
52	Umaru's Houseware Store	<a href="https://tr.aliexpress.com/store/2400091">https://tr.aliexpress.com/store/2400091</a>	<a href="https://www.aliexpress.com/item/2018-Hot-Sale-Egg-Shell-Peeler-Slicer-Remover-Dividers-Plastic-Egg-Scissor-Cutter-Handle-Egg-Tools/32871152682.html">https://www.aliexpress.com/item/2018-Hot-Sale-Egg-Shell-Peeler-Slicer-Remover-Dividers-Plastic-Egg-Scissor-Cutter-Handle-Egg-Tools/32871152682.html</a>	Aliexpress.com	8/3/2018

**DATES OF SERVICE FOR DEFENDANTS ON AMENDED SCHEDULE "A"**

Def No.	Defendant by Seller ID	URL of Defendant's Merchant Storefront	ASIN/Prod ID/URL	Third Party Service Provider	Service Date
53	Shop1033157 Store	<a href="https://tr.aliexpress.com/store/1033157">https://tr.aliexpress.com/store/1033157</a>	<a href="https://www.aliexpress.com/item/Plastic-Egg-Shell-Peeler-Egg-Slicer-Cutter-Egg-Shell-Separator-Scissors-Peeling-Tool-Household-Kitchen-Cooking/32868766593.html">https://www.aliexpress.com/item/Plastic-Egg-Shell-Peeler-Egg-Slicer-Cutter-Egg-Shell-Separator-Scissors-Peeling-Tool-Household-Kitchen-Cooking/32868766593.html</a>	Aliexpress.com	8/3/2018
54	Best Home lifestyle	<a href="https://tr.aliexpress.com/store/2022020">https://tr.aliexpress.com/store/2022020</a>	<a href="https://www.aliexpress.com/item/Egg-Shell-Peeler-Plastic-Egg-Slicer-Egg-Shell-Separator-Hard-boiled-Scissors-Peeling-Tool-Household-Kitchen/32882673944.html">https://www.aliexpress.com/item/Egg-Shell-Peeler-Plastic-Egg-Slicer-Egg-Shell-Separator-Hard-boiled-Scissors-Peeling-Tool-Household-Kitchen/32882673944.html</a>	Aliexpress.com	8/3/2018
55	Loving Warm Home	<a href="https://tr.aliexpress.com/store/237015">https://tr.aliexpress.com/store/237015</a>	<a href="https://www.aliexpress.com/item/Eggs-Shell-Peelers-Slicer-Remover-Dividers-Plastic-Eggs-Scissor-Cutter-Handle-Eggs-Tools-Kitchen-Accessories-Cooking/32884904338.html">https://www.aliexpress.com/item/Eggs-Shell-Peelers-Slicer-Remover-Dividers-Plastic-Eggs-Scissor-Cutter-Handle-Eggs-Tools-Kitchen-Accessories-Cooking/32884904338.html</a>	Aliexpress.com	8/3/2018
56	TOPATY Store	<a href="https://tr.aliexpress.com/store/3174028">https://tr.aliexpress.com/store/3174028</a>	<a href="https://www.aliexpress.com/item/Plastic-Egg-Shell-Peeler-Egg-Slicer-Cutter-Egg-Shell-Separator-Scissors-Peeling-Tool-Household-Kitchen-Cooking/32876356216.html">https://www.aliexpress.com/item/Plastic-Egg-Shell-Peeler-Egg-Slicer-Cutter-Egg-Shell-Separator-Scissors-Peeling-Tool-Household-Kitchen-Cooking/32876356216.html</a>	Aliexpress.com	8/3/2017
57	Sunshine-store	<a href="https://tr.aliexpress.com/store/407893">https://tr.aliexpress.com/store/407893</a>	<a href="https://www.aliexpress.com/item/2018-New-Arrival-Egg-Shell-Peeler-Egg-Slicer-Cutter-Peeling-Egg-Separator-Tool-Kitchen-Accessories-Home/32864649696.html">https://www.aliexpress.com/item/2018-New-Arrival-Egg-Shell-Peeler-Egg-Slicer-Cutter-Peeling-Egg-Separator-Tool-Kitchen-Accessories-Home/32864649696.html</a>	Aliexpress.com	8/3/2018
58	Leading lifestyle store	<a href="https://tr.aliexpress.com/store/1359042">https://tr.aliexpress.com/store/1359042</a>	<a href="https://www.aliexpress.com/item/Egg-Shell-Peeler-Egg-Slicer-Cutter-Peeling-Tool-Boiled-Egg-Peeler-Home-Egg-Slicer-Kitchen-Gadgets/32873147815.html">https://www.aliexpress.com/item/Egg-Shell-Peeler-Egg-Slicer-Cutter-Peeling-Tool-Boiled-Egg-Peeler-Home-Egg-Slicer-Kitchen-Gadgets/32873147815.html</a>	Aliexpress.com	8/3/2018
59	Sweet dream family center98	<a href="https://tr.aliexpress.com/store/1752437">https://tr.aliexpress.com/store/1752437</a>	<a href="https://www.aliexpress.com/item/SDFC-Egg-Shell-Peeler-Egg-Slicer-Cutter-Peeling-Tool-egg-Peeler-Kitchen-Tool-Home-Egg-Slicer/32883000579.html">https://www.aliexpress.com/item/SDFC-Egg-Shell-Peeler-Egg-Slicer-Cutter-Peeling-Tool-egg-Peeler-Kitchen-Tool-Home-Egg-Slicer/32883000579.html</a>	Aliexpress.com	8/3/2018
60	Poodle XiaoCoCos Shop Store	<a href="https://he.aliexpress.com/store/3508046">https://he.aliexpress.com/store/3508046</a>	<a href="https://www.aliexpress.com/item/Egg-Shell-Peeler-Egg-Slicer-Cutter-Peeling-Tool-egg-Peeler-Kitchen-Tool-Home-Egg-Slicer-Stainless/32869262671.html">https://www.aliexpress.com/item/Egg-Shell-Peeler-Egg-Slicer-Cutter-Peeling-Tool-egg-Peeler-Kitchen-Tool-Home-Egg-Slicer-Stainless/32869262671.html</a>	Aliexpress.com	8/3/2018
61	Innovation Drinkware Store	<a href="https://www.aliexpress.com/store/3106052">https://www.aliexpress.com/store/3106052</a>	<a href="https://www.aliexpress.com/item/Egg-Shell-Peeler-Egg-Slicer-Cutter-Peeling-Tool-Boiled-Egg-Peeler-Home-Egg-Slicer-Kitchen-Gadgets/32869840511.html">https://www.aliexpress.com/item/Egg-Shell-Peeler-Egg-Slicer-Cutter-Peeling-Tool-Boiled-Egg-Peeler-Home-Egg-Slicer-Kitchen-Gadgets/32869840511.html</a>	Aliexpress.com	8/3/2018
62	CHINA REASARD Store	<a href="https://www.aliexpress.com/store/1440008">https://www.aliexpress.com/store/1440008</a>	<a href="https://www.aliexpress.com/item/2018-New-arrival-Egg-Shell-Peeler-Egg-Slicer-Cutter-Peeling-Tool-egg-Peeler-Kitchen-Tool-Home/32856970557.html">https://www.aliexpress.com/item/2018-New-arrival-Egg-Shell-Peeler-Egg-Slicer-Cutter-Peeling-Tool-egg-Peeler-Kitchen-Tool-Home/32856970557.html</a>	Aliexpress.com	8/3/2018
63	Enjoys Life Store	<a href="https://www.aliexpress.com/store/2947149">https://www.aliexpress.com/store/2947149</a>	<a href="https://www.aliexpress.com/item/Egg-Shell-Peeler-Egg-Slicer-Cutter-Peeling-Tool-Boiled-Egg-Peeler-Home-Egg-Slicer-Kitchen-Gadgets/32888789296.html">https://www.aliexpress.com/item/Egg-Shell-Peeler-Egg-Slicer-Cutter-Peeling-Tool-Boiled-Egg-Peeler-Home-Egg-Slicer-Kitchen-Gadgets/32888789296.html</a>	Aliexpress.com	8/3/2018
64	Noachic café Store	<a href="https://he.aliexpress.com/store/3178001">https://he.aliexpress.com/store/3178001</a>	<a href="https://www.aliexpress.com/item/NOCM-Egg-Shell-Peeler-Egg-Slicer-Cutter-Peeling-Tool-egg-Peeler-Kitchen-Tool-Home-Egg-Slicer/32862761602.html">https://www.aliexpress.com/item/NOCM-Egg-Shell-Peeler-Egg-Slicer-Cutter-Peeling-Tool-egg-Peeler-Kitchen-Tool-Home-Egg-Slicer/32862761602.html</a>	Aliexpress.com	8/3/2018
65	Aladinging Store	<a href="https://www.aliexpress.com/store/3630083">https://www.aliexpress.com/store/3630083</a>	<a href="https://www.aliexpress.com/item/Plastic-Egg-Shell-Peeler-Egg-Slicer-Cutter-Egg-Shell-Separator-Scissors-Peeling-Tool-Household-Kitchen-Cooking/32868123627.html">https://www.aliexpress.com/item/Plastic-Egg-Shell-Peeler-Egg-Slicer-Cutter-Egg-Shell-Separator-Scissors-Peeling-Tool-Household-Kitchen-Cooking/32868123627.html</a>	Aliexpress.com	8/3/2018
66	Institute of Food	<a href="https://www.aliexpress.com/store/1866025">https://www.aliexpress.com/store/1866025</a>	<a href="https://www.aliexpress.com/item/Plastic-Manual-Eggs-Shell-Peeler-Egg-Slicer-Cutter-Peeling-Tools-Eggs-Separator-Kitchen-Accessories/32885962368.html">https://www.aliexpress.com/item/Plastic-Manual-Eggs-Shell-Peeler-Egg-Slicer-Cutter-Peeling-Tools-Eggs-Separator-Kitchen-Accessories/32885962368.html</a>	Aliexpress.com	8/3/2018

**DATES OF SERVICE FOR DEFENDANTS ON AMENDED SCHEDULE "A"**

Def No.	Defendant by Seller ID	URL of Defendant's Merchant Storefront	ASIN/Prod ID/URL	Third Party Service Provider	Service Date
67	SKU Co., Ltd. Store	<a href="https://www.aliexpress.com/store/2344160">https://www.aliexpress.com/store/2344160</a>	<a href="https://www.aliexpress.com/item/Manual-Eggs-Sheller-Plastic-Eggs-Shell-Peeler-Eggs-Slicer-Cutter-Peeling-Tools-Eggs-Separator-Cooking-Tools/32885930768.html">https://www.aliexpress.com/item/Manual-Eggs-Sheller-Plastic-Eggs-Shell-Peeler-Eggs-Slicer-Cutter-Peeling-Tools-Eggs-Separator-Cooking-Tools/32885930768.html</a>	Aliexpress.com	8/3/2018
68	sweethome-sale	<a href="https://www.aliexpress.com/store/1656297">https://www.aliexpress.com/store/1656297</a>	<a href="https://www.aliexpress.com/item/Kitchen-Manual-Eggs-Sheller-Eggs-Shell-Peeler-Eggs-Slicer-Cutter-Peeling-Tools-Eggs-Separator-Accessories-Cooking/32886127204.html">https://www.aliexpress.com/item/Kitchen-Manual-Eggs-Sheller-Eggs-Shell-Peeler-Eggs-Slicer-Cutter-Peeling-Tools-Eggs-Separator-Accessories-Cooking/32886127204.html</a>	Aliexpress.com	8/3/2018
69	Fashion Store A8	<a href="https://www.aliexpress.com/store/1907984">https://www.aliexpress.com/store/1907984</a>	<a href="https://www.aliexpress.com/item/Instantly-Hard-Boiled-Egg-Shell-Peeler-Red-Black-Yellow-White/32875295957.html">https://www.aliexpress.com/item/Instantly-Hard-Boiled-Egg-Shell-Peeler-Red-Black-Yellow-White/32875295957.html</a>	Aliexpress.com	8/3/2018
70	Worldwide Dropshipping Store	<a href="https://www.aliexpress.com/store/3204074">https://www.aliexpress.com/store/3204074</a>	<a href="https://www.aliexpress.com/item/Egg-Shell-Peeler-Kitchen-Cooking-Tool-Plastic-Egg-Slicer-Cutter-Egg-Shell-Separator-Scissors-Peeling-Tool/32868346443.html">https://www.aliexpress.com/item/Egg-Shell-Peeler-Kitchen-Cooking-Tool-Plastic-Egg-Slicer-Cutter-Egg-Shell-Separator-Scissors-Peeling-Tool/32868346443.html</a>	Aliexpress.com	8/3/2018
71	Dolly's Artng Life	<a href="https://www.aliexpress.com/store/2348069">https://www.aliexpress.com/store/2348069</a>	<a href="https://www.aliexpress.com/item/Hard-Boiled-Egg-Shell-Peeler-Detachable-High-Quality-Egg-Shell-Peeler/32885187978.html">https://www.aliexpress.com/item/Hard-Boiled-Egg-Shell-Peeler-Detachable-High-Quality-Egg-Shell-Peeler/32885187978.html</a>	Aliexpress.com	8/3/2018
72	goodfeer-Store	<a href="https://www.aliexpress.com/store/3359003">https://www.aliexpress.com/store/3359003</a>	<a href="https://www.aliexpress.com/item/1PC-Manually-Egg-Sheller-Portable-Hard-Boiled-Egg-Shell-Separator-TV-Remove-Peeler-Magic-Amazing-Eggshell/32888161812.html">https://www.aliexpress.com/item/1PC-Manually-Egg-Sheller-Portable-Hard-Boiled-Egg-Shell-Separator-TV-Remove-Peeler-Magic-Amazing-Eggshell/32888161812.html</a>	Aliexpress.com	8/3/2018
73	Go-Homing Store	<a href="https://www.aliexpress.com/store/2665213">https://www.aliexpress.com/store/2665213</a>	<a href="https://www.aliexpress.com/item/Cooked-Egg-Peeler-Hard-Hard-Boiled-Egg-Shell-Peeler-Peeling-Kitchen-Tool-3-16/32856829561.html">https://www.aliexpress.com/item/Cooked-Egg-Peeler-Hard-Hard-Boiled-Egg-Shell-Peeler-Peeling-Kitchen-Tool-3-16/32856829561.html</a>	Aliexpress.com	8/3/2018
74	YY Luckily Store	<a href="https://www.aliexpress.com/store/3889028">https://www.aliexpress.com/store/3889028</a>	<a href="https://www.aliexpress.com/item/Cooked-Egg-Sheller-Peeling-Eggshell-to-Cooked-Chicken-Eggshell-Tools/32862174731.html">https://www.aliexpress.com/item/Cooked-Egg-Sheller-Peeling-Eggshell-to-Cooked-Chicken-Eggshell-Tools/32862174731.html</a>	Aliexpress.com	8/3/2018
75	Unique Life Store	<a href="https://tr.aliexpress.com/store/3567033">https://tr.aliexpress.com/store/3567033</a>	<a href="https://www.aliexpress.com/item/Egg-Peeler-Cutter-Peeling-Tool-Kitchen-Tool-Egg-Shell-Separator/32880865071.html">https://www.aliexpress.com/item/Egg-Peeler-Cutter-Peeling-Tool-Kitchen-Tool-Egg-Shell-Separator/32880865071.html</a>	Aliexpress.com	8/3/2018
76	Sunfei	<a href="https://www.amazon.com/s?merchant=A1AFVBU00XGZ">https://www.amazon.com/s?merchant=A1AFVBU00XGZ</a>	B01NATZUY2, B01N235WK4	Amazon.com	8/2/2018
77	Some Interesting Store	<a href="https://www.amazon.com/s?merchant=A1V9U5HSNV2CRF">https://www.amazon.com/s?merchant=A1V9U5HSNV2CRF</a>	B07BFT9WBZ	Amazon.com	8/2/2018
78	Zfitei	<a href="https://www.amazon.com/s?merchant=A300Y12PDYH5KA">https://www.amazon.com/s?merchant=A300Y12PDYH5KA</a>	B07CKPV969	Amazon.com	8/2/2018
79	Wishesport	<a href="https://www.amazon.com/s?merchant=A1EB5Q82D25KP">https://www.amazon.com/s?merchant=A1EB5Q82D25KP</a>	B07DBY9WHZ	Amazon.com	8/2/2018
80	SMY TShop	<a href="https://www.amazon.com/SMY TShop/b/ref=aj_dp_s_web_17227385011?ie=UTF8&amp;node=17227385011&amp;ie=UTF8&amp;brand=browse-bin=SMY TShop">https://www.amazon.com/SMY TShop/b/ref=aj_dp_s_web_17227385011?ie=UTF8&amp;node=17227385011&amp;ie=UTF8&amp;brand=browse-bin=SMY TShop</a>	B07BHQKQTD	Amazon.com	8/2/2018
81	Formemory	<a href="https://www.amazon.com/s?merchant=A24E400AXST0AQ">https://www.amazon.com/s?merchant=A24E400AXST0AQ</a>	B07CV9Y5S8	Amazon.com	8/2/2018
82	Baoblaze	<a href="https://www.amazon.com/s?merchant=A3C8YK6W3F5UNV">https://www.amazon.com/s?merchant=A3C8YK6W3F5UNV</a>	B07D394V6F	Amazon.com	8/2/2018

**DATES OF SERVICE FOR DEFENDANTS ON AMENDED SCHEDULE "A"**

Def No.	Defendant by Seller ID	URL of Defendant's Merchant Storefront	ASIN/Prod ID/URL	Third Party Service Provider	Service Date
83	Dolify Home	<a href="https://www.amazon.com/s?merchant=A1Z84CWL7LX7P">https://www.amazon.com/s?merchant=A1Z84CWL7LX7P</a>	B07D36YT2W	Amazon.com	8/2/2018
84	Brandon Trollpoe	<a href="https://www.amazon.com/s?merchant=A2UFZEWWULRAZI">https://www.amazon.com/s?merchant=A2UFZEWWULRAZI</a>	B07B2H3YQD, B07B2H6YB7	Amazon.com	8/2/2018
85	HoLeis	<a href="https://www.amazon.com/s?merchant=A22HBOFS74E6FF">https://www.amazon.com/s?merchant=A22HBOFS74E6FF</a>	B07BD5576N, B07BD554PR	Amazon.com	8/2/2018
86	TiLarry	<a href="https://www.amazon.com/s?merchant=A2W9F9DWU65XVL">https://www.amazon.com/s?merchant=A2W9F9DWU65XVL</a>	B07D7V5YVZ	Amazon.com	8/2/2018
87	HOMEFUL	<a href="https://www.amazon.com/Homeful/b/ref=wl_hsx_s_ki_web_15180153011?ie=UTF8&amp;node=15180153011&amp;field-lbr_brands_browse-bin=Homeful">https://www.amazon.com/Homeful/b/ref=wl_hsx_s_ki_web_15180153011?ie=UTF8&amp;node=15180153011&amp;field-lbr_brands_browse-bin=Homeful</a>	Any of the following ASIN numbers: ASIN: B07CGN969R, B07CVBB6G1, B07B2H6YB7, B07BYWX91M, B07DFZHL5T, B07CBNK5VB, B07CM1GF1W, B07B2H3YQD, B07BD5576N, B07D1251GY, B07D6MK5V2, B07CWFQXX8, B07D5W33BW, B07CV9R266, B07D5VXMOM, B07CH5N88D, B07D5WDCBX, B07D1Q4VRD, B07C7VQ57W, B07DFZ4NJ4	Amazon.com	8/2/2018
88	Labu Store	<a href="https://www.amazon.com/s?merchant=A1EFTOGAHWGAZS">https://www.amazon.com/s?merchant=A1EFTOGAHWGAZS</a>	Any of the following ASIN numbers: ASIN: B07CGN969R, B07CVBB6G1, B07B2H6YB7, B07BYWX91M, B07DFZHL5T, B07CBNK5VB, B07CM1GF1W, B07B2H3YQD, B07BD5576N, B07D1251GY, B07D6MK5V2, B07CWFQXX8, B07D5W33BW, B07CV9R266, B07D5VXMOM, B07CH5N88D, B07D5WDCBX, B07D1Q4VRD, B07C7VQ57W, B07DFZ4NJ4	Amazon.com	8/2/2018
89	ordon.piotr	<a href="https://www.amazon.com/s?merchant=A3H540WT3BSRHB">https://www.amazon.com/s?merchant=A3H540WT3BSRHB</a>	Any of the following ASIN numbers: ASIN: B07CGN969R, B07CVBB6G1, B07B2H6YB7, B07BYWX91M, B07DFZHL5T, B07CBNK5VB, B07CM1GF1W, B07B2H3YQD, B07BD5576N, B07D1251GY, B07D6MK5V2, B07CWFQXX8, B07D5W33BW, B07CV9R266, B07D5VXMOM, B07CH5N88D, B07D5WDCBX, B07D1Q4VRD, B07C7VQ57W, B07DFZ4NJ4	Amazon.com	8/2/2018
90	Brad2016	<a href="https://www.dhgate.com/store/20127433">https://www.dhgate.com/store/20127433</a>	<a href="https://www.dhgate.com/product/plastic-egg-shell-peeler-egg-slicer-cutter/412601483.html">https://www.dhgate.com/product/plastic-egg-shell-peeler-egg-slicer-cutter/412601483.html</a>	dhgate.com	8/3/2018
91	dhgate_factory01	<a href="https://www.dhgate.com/store/20644561">https://www.dhgate.com/store/20644561</a>	<a href="https://www.dhgate.com/store/product/2018-new-arrival-egg-shell-peeler-egg-slicer/411089513.html">https://www.dhgate.com/store/product/2018-new-arrival-egg-shell-peeler-egg-slicer/411089513.html</a>	dhgate.com	8/3/2018
92	dhgatetop_merchant	<a href="https://www.dhgate.com/store/20748377">https://www.dhgate.com/store/20748377</a>	<a href="https://www.dhgate.com/store/product/plastic-egg-shell-peeler-egg-slicer-cutter/411089748.html">https://www.dhgate.com/store/product/plastic-egg-shell-peeler-egg-slicer-cutter/411089748.html</a>	dhgate.com	8/3/2018

## DATES OF SERVICE FOR DEFENDANTS ON AMENDED SCHEDULE "A"

Def No.	Defendant by Seller ID	URL of Defendant's Merchant Storefront	ASIN/Prod ID/URL	Third Party Service Provider	Service Date
93	greatseller	<a href="https://www.ebay.com/usr/greatseller">https://www.ebay.com/usr/greatseller</a>	<a href="https://www.ebay.com/itm/Hard-boiled-Egg-Peeler-Hard-boiled-Egg-Peeler-the-negg-Hard-boiled-Egg-Peeler/113077459319">https://www.ebay.com/itm/Hard-boiled-Egg-Peeler-Hard-boiled-Egg-Peeler-the-negg-Hard-boiled-Egg-Peeler/113077459319</a> <a href="https://www.ebay.com/itm/Hard-boiled-Egg-Peeler-Hard-boiled-Egg-Peeler/113079032121">https://www.ebay.com/itm/Hard-boiled-Egg-Peeler-Hard-boiled-Egg-Peeler/113079032121</a>	ebay.com	7/31/2018
94	zouelbr_0	<a href="https://www.ebay.com/usr/zouelbr_0">https://www.ebay.com/usr/zouelbr_0</a>	<a href="https://www.ebay.com/itm/The-Negg-Hard-boiled-Egg-Peeler-Solutions-Egg-Peeler-Hard-Boiled-NIB/123191929460">https://www.ebay.com/itm/The-Negg-Hard-boiled-Egg-Peeler-Solutions-Egg-Peeler-Hard-Boiled-NIB/123191929460</a>	ebay.com	7/31/2018
95	2017junmei	<a href="https://www.ebay.com/usr/2017junmei">https://www.ebay.com/usr/2017junmei</a>	<a href="https://www.ebay.com/itm/The-Negg-Hard-boiled-Egg-Peeler-Solutions-Egg-Peeler-Hard-Boiled-NIB/273304414722">https://www.ebay.com/itm/The-Negg-Hard-boiled-Egg-Peeler-Solutions-Egg-Peeler-Hard-Boiled-NIB/273304414722</a>	ebay.com	7/31/2018
96	melyodas0	<a href="https://www.ebay.com/usr/melyodas0">https://www.ebay.com/usr/melyodas0</a>	<a href="https://www.ebay.com/itm/The-Negg-Hard-boiled-Egg-Peeler-Solutions-Egg-Peeler-Hard-Boiled-NIB/253692916710">https://www.ebay.com/itm/The-Negg-Hard-boiled-Egg-Peeler-Solutions-Egg-Peeler-Hard-Boiled-NIB/253692916710</a>	ebay.com	7/31/2018
97	best_4youu	<a href="https://www.ebay.com/usr/best_4youu">https://www.ebay.com/usr/best_4youu</a>	<a href="https://www.ebay.com/itm/The-Negg-Hard-boiled-Egg-Peeler-Solutions-Egg-Peeler-Hard-Boiled-NIB/253692944819">https://www.ebay.com/itm/The-Negg-Hard-boiled-Egg-Peeler-Solutions-Egg-Peeler-Hard-Boiled-NIB/253692944819</a>	ebay.com	7/31/2018
98	trustworthy404	<a href="https://www.ebay.com/usr/trustworthy404">https://www.ebay.com/usr/trustworthy404</a>	<a href="https://www.ebay.com/itm/GIVEAWAY-PRICE-The-Negg-Hard-boiled-Egg-Peeler-solution-New-Easy-Fast-Fun/123195686381">https://www.ebay.com/itm/GIVEAWAY-PRICE-The-Negg-Hard-boiled-Egg-Peeler-solution-New-Easy-Fast-Fun/123195686381</a>	ebay.com	7/31/2018
99	2015ilbruc	<a href="https://www.ebay.com/usr/2015ilbruc">https://www.ebay.com/usr/2015ilbruc</a>	<a href="https://www.ebay.com/itm/THE-NEGG-BOILED-EGG-PEELER-RED/253349759131">https://www.ebay.com/itm/THE-NEGG-BOILED-EGG-PEELER-RED/253349759131</a>	ebay.com	7/31/2018
100	pacificfantastic	<a href="https://www.ebay.com/usr/pacificfantastic">https://www.ebay.com/usr/pacificfantastic</a>	<a href="https://www.ebay.com/itm/THE-NEGG-BOILED-EGG-PEELER-YELLOW/192569771545">https://www.ebay.com/itm/THE-NEGG-BOILED-EGG-PEELER-YELLOW/192569771545</a>	ebay.com	7/31/2018
101	silvishop15	<a href="https://www.ebay.com/usr/silvishop15">https://www.ebay.com/usr/silvishop15</a>	<a href="https://www.ebay.com/itm/THE-NEGG-BOILED-EGG-PEELER-RED-home-kitchen-tool/192471319693">https://www.ebay.com/itm/THE-NEGG-BOILED-EGG-PEELER-RED-home-kitchen-tool/192471319693</a>	ebay.com	7/31/2018
102	xoxdianzi	<a href="https://www.ebay.com/usr/xoxdianzi">https://www.ebay.com/usr/xoxdianzi</a>	<a href="https://www.ebay.com/itm/Egg-Peeler-Solutions-Egg-Peeler-Hard-Boiled-NIBThe-Negg-Hard-Boiled-Multicolor/323311377257">https://www.ebay.com/itm/Egg-Peeler-Solutions-Egg-Peeler-Hard-Boiled-NIBThe-Negg-Hard-Boiled-Multicolor/323311377257</a>	ebay.com	7/31/2018
103	nalimat	<a href="https://www.ebay.com/usr/nalimat">https://www.ebay.com/usr/nalimat</a>	<a href="https://www.ebay.com/itm/Egg-Shell-Peeler-Egg-Slicer-Cutter-Peeling-Tool-egg-Peeler-Kitchen-Tool-Home/232804767876">https://www.ebay.com/itm/Egg-Shell-Peeler-Egg-Slicer-Cutter-Peeling-Tool-egg-Peeler-Kitchen-Tool-Home/232804767876</a>	ebay.com	7/31/2018

**DATES OF SERVICE FOR DEFENDANTS ON AMENDED SCHEDULE "A"**

Def No.	Defendant by Seller ID	URL of Defendant's Merchant Storefront	ASIN/Prod ID/URL	Third Party Service Provider	Service Date
104	kitsimple sale	<a href="https://www.ebay.com/usr/kitsimple sale">https://www.ebay.com/usr/kitsimple sale</a>	<a href="https://www.ebay.com/itm/New-Egg-Shell-Peeler-Egg-Slicer-RED-Peeling-Tool-egg-Peeler-Kitchen-Tool-Egg/263774467518">https://www.ebay.com/itm/New-Egg-Shell-Peeler-Egg-Slicer-RED-Peeling-Tool-egg-Peeler-Kitchen-Tool-Egg/263774467518</a>	ebay.com	7/31/2018
105	hanoune_9816	<a href="https://www.ebay.com/usr/hanoune_9816">https://www.ebay.com/usr/hanoune_9816</a>	<a href="https://www.ebay.com/itm/New-Egg-Shell-Peeler-Egg-Slicer-Cutter-Peeling-Tool-egg-Peeler-Kitchen-Tool-Egg/192551929794">https://www.ebay.com/itm/New-Egg-Shell-Peeler-Egg-Slicer-Cutter-Peeling-Tool-egg-Peeler-Kitchen-Tool-Egg/192551929794</a>	ebay.com	7/31/2018
106	amal-gadgets-shop	<a href="https://www.ebay.com/usr/amal-gadgets-shop">https://www.ebay.com/usr/amal-gadgets-shop</a>	<a href="https://www.ebay.com/itm/Egg-Shell-Peeler-Egg-Slicer-Cutter-Peeling-Tool-egg-Peeler-Kitchen-Tool-Home/113022421287">https://www.ebay.com/itm/Egg-Shell-Peeler-Egg-Slicer-Cutter-Peeling-Tool-egg-Peeler-Kitchen-Tool-Home/113022421287</a>	ebay.com	7/31/2018
107	ultimate1seller	<a href="https://www.ebay.com/usr/ultimate1seller">https://www.ebay.com/usr/ultimate1seller</a>	<a href="https://www.ebay.com/itm/New-Egg-Shell-Peeler-Egg-Slicer-Cutter-Peeling-Tool-egg-Peeler-Kitchen-Tool-Home/253729863381">https://www.ebay.com/itm/New-Egg-Shell-Peeler-Egg-Slicer-Cutter-Peeling-Tool-egg-Peeler-Kitchen-Tool-Home/253729863381</a>	ebay.com	7/31/2018
108	yihangjc	<a href="https://www.ebay.com/usr/yihangjc">https://www.ebay.com/usr/yihangjc</a>	<a href="https://www.ebay.com/itm/The-Negg-Red-Black-White-Yellow-Bv-Airjigan-Solutions-Egg-Peeler-Hard-Boiled-NIB/292628390888">https://www.ebay.com/itm/The-Negg-Red-Black-White-Yellow-Bv-Airjigan-Solutions-Egg-Peeler-Hard-Boiled-NIB/292628390888</a>	ebay.com	7/31/2018
109	cqfgs	<a href="https://www.ebay.com/usr/cqfgs">https://www.ebay.com/usr/cqfgs</a>	<a href="https://www.ebay.com/itm/The-Negg-Hard-boiled-Egg-Peeler-Solutions-Egg-Peeler-Hard-Boiled-NIB/323321008780">https://www.ebay.com/itm/The-Negg-Hard-boiled-Egg-Peeler-Solutions-Egg-Peeler-Hard-Boiled-NIB/323321008780</a>	ebay.com	7/31/2018
110	qwwdss	<a href="https://www.ebay.com/usr/qwwdss">https://www.ebay.com/usr/qwwdss</a>	<a href="https://www.ebay.com/itm/The-Negg-Hard-boiled-Egg-Peeler-Solutions-Egg-Peeler-Hard-Boiled-NIB/223039658674">https://www.ebay.com/itm/The-Negg-Hard-boiled-Egg-Peeler-Solutions-Egg-Peeler-Hard-Boiled-NIB/223039658674</a>	ebay.com	7/31/2018
111	HIENGCHU	<a href="https://www.wish.com/merchant/555dc3638eb01b1296deca8e">https://www.wish.com/merchant/555dc3638eb01b1296deca8e</a>	<a href="https://www.wish.com/c/5aa397e62ef55117a1135ffd">https://www.wish.com/c/5aa397e62ef55117a1135ffd</a>	wish.com	7/31/2018
112	fengdingluohua	<a href="https://www.wish.com/merchant/58ccad88fa2f4571564c0098">https://www.wish.com/merchant/58ccad88fa2f4571564c0098</a>	<a href="https://www.wish.com/c/5aea1a96b5708891274c5f9ad">https://www.wish.com/c/5aea1a96b5708891274c5f9ad</a>	wish.com	7/31/2018
113	Coollyard	<a href="https://www.wish.com/merchant/5a994e5b18d9210fef67d0dc">https://www.wish.com/merchant/5a994e5b18d9210fef67d0dc</a>	<a href="https://www.wish.com/c/5aabf9fb8304257110a780ab">https://www.wish.com/c/5aabf9fb8304257110a780ab</a>	wish.com	7/31/2018
114	vakind2018	<a href="https://www.wish.com/merchant/5374509f7360464b6b25f8fb">https://www.wish.com/merchant/5374509f7360464b6b25f8fb</a>	<a href="https://www.wish.com/c/5b0cb99bc13755386e171543">https://www.wish.com/c/5b0cb99bc13755386e171543</a>	wish.com	7/31/2018
115	gudaobigworld	<a href="https://www.wish.com/merchant/58256ca227e1ab4891f66f6c">https://www.wish.com/merchant/58256ca227e1ab4891f66f6c</a>	<a href="https://www.wish.com/c/5a9991c21a8c2172841a2dfb">https://www.wish.com/c/5a9991c21a8c2172841a2dfb</a>	wish.com	7/31/2018
116	Mygiffshop	<a href="https://www.wish.com/merchant/5800b551746f2b55f423f319">https://www.wish.com/merchant/5800b551746f2b55f423f319</a>	<a href="https://www.wish.com/c/5a9cee05c7e80b0e75986cae">https://www.wish.com/c/5a9cee05c7e80b0e75986cae</a>	wish.com	7/31/2018
117	PowerMup	<a href="https://www.wish.com/merchant/59e7f8e20a32a5f879688a0">https://www.wish.com/merchant/59e7f8e20a32a5f879688a0</a>	<a href="https://www.wish.com/c/5aa962047c74933704fe806e">https://www.wish.com/c/5aa962047c74933704fe806e</a>	wish.com	7/31/2018
118	WildLion	<a href="https://www.wish.com/merchant/5a9e6935b9605f19fc287c15">https://www.wish.com/merchant/5a9e6935b9605f19fc287c15</a>	<a href="https://www.wish.com/c/5ac8a738c7e80b08143859c7">https://www.wish.com/c/5ac8a738c7e80b08143859c7</a>	wish.com	7/31/2018
119	youneedit	<a href="https://www.wish.com/merchant/5a167cb20c47f37889e98d54">https://www.wish.com/merchant/5a167cb20c47f37889e98d54</a>	<a href="https://www.wish.com/c/5acc602fbd784c5096f3a332">https://www.wish.com/c/5acc602fbd784c5096f3a332</a>	wish.com	7/31/2018

**DATES OF SERVICE FOR DEFENDANTS ON AMENDED SCHEDULE "A"**

Def No.	Defendant by Seller ID	URL of Defendant's Merchant Storefront	ASIN/Prod ID/URL	Third Party Service Provider	Service Date
120	AdventureHelper	<a href="https://www.wish.com/merchant/5e9e1b57b125ab05e5addc06">https://www.wish.com/merchant/5e9e1b57b125ab05e5addc06</a>	<a href="https://www.wish.com/c/5af29747ce2c7013f6f657fc">https://www.wish.com/c/5af29747ce2c7013f6f657fc</a>	wish.com	7/31/2018
121	Lilang Da Technology	<a href="https://www.wish.com/merchant/56fb8ae885558c2865934047">https://www.wish.com/merchant/56fb8ae885558c2865934047</a>	<a href="https://www.wish.com/c/5a3cb4b3e3eb0879b4a66037">https://www.wish.com/c/5a3cb4b3e3eb0879b4a66037</a>	wish.com	7/31/2018
122	UnbeatableSale.com	<a href="https://www.wish.com/merchant/5877e44ba35cef278491f32e">https://www.wish.com/merchant/5877e44ba35cef278491f32e</a>	<a href="https://www.wish.com/c/5ab3e46e1ab08a02cdd2f953">https://www.wish.com/c/5ab3e46e1ab08a02cdd2f953</a>	wish.com	7/31/2018
123	treebackwe18	<a href="https://www.wish.com/merchant/5954a1654b913a627e41e7fa">https://www.wish.com/merchant/5954a1654b913a627e41e7fa</a>	<a href="https://www.wish.com/c/5aaa6f1ba7d4840cebc1060">https://www.wish.com/c/5aaa6f1ba7d4840cebc1060</a>	wish.com	7/31/2018
124	Fashion-Master	<a href="https://www.wish.com/merchant/54815a6240b37805abe61d30">https://www.wish.com/merchant/54815a6240b37805abe61d30</a>	<a href="https://www.wish.com/c/5ab8524147a0e73f1de9dbd4">https://www.wish.com/c/5ab8524147a0e73f1de9dbd4</a>	wish.com	7/31/2018
125	Rogerww	<a href="https://www.wish.com/merchant/577cd7d7bf215340c1f126da">https://www.wish.com/merchant/577cd7d7bf215340c1f126da</a>	<a href="https://www.wish.com/c/5ad6ff97a7d484496e48a20d">https://www.wish.com/c/5ad6ff97a7d484496e48a20d</a>	wish.com	7/31/2018
126	PowerMup	<a href="https://www.wish.com/merchant/59e7f8e20a332a5f879688a0">https://www.wish.com/merchant/59e7f8e20a332a5f879688a0</a>	<a href="https://www.wish.com/c/5aa28448bd784c763336fd099">https://www.wish.com/c/5aa28448bd784c763336fd099</a>	wish.com	7/31/2018
127	coververse	<a href="https://www.wish.com/merchant/53426c2b7360467126e3120">https://www.wish.com/merchant/53426c2b7360467126e3120</a>	<a href="https://www.wish.com/c/5aab425c1a8c212fb379a01e">https://www.wish.com/c/5aab425c1a8c212fb379a01e</a>	wish.com	7/31/2018
128	Embroidered shop	<a href="https://www.wish.com/merchant/587363c69ed2cb4d4a84b189">https://www.wish.com/merchant/587363c69ed2cb4d4a84b189</a>	<a href="https://www.wish.com/c/5ab888dae7ddb0652fe1fa02c">https://www.wish.com/c/5ab888dae7ddb0652fe1fa02c</a>	wish.com	7/31/2018
129	moraltop	<a href="https://www.wish.com/merchant/55d3e4b92e9ba122fbd6cc4">https://www.wish.com/merchant/55d3e4b92e9ba122fbd6cc4</a>	<a href="https://www.wish.com/c/5aab66725e2ae1746445b4b4">https://www.wish.com/c/5aab66725e2ae1746445b4b4</a>	wish.com	7/31/2018
130	jingpinghuadian	<a href="https://www.wish.com/merchant/5ac9c4952fbbdc42f95f847f">https://www.wish.com/merchant/5ac9c4952fbbdc42f95f847f</a>	<a href="https://www.wish.com/c/5ad25c8ea69e663716cee53a">https://www.wish.com/c/5ad25c8ea69e663716cee53a</a>	wish.com	7/31/2018
131	themarket	<a href="https://www.wish.com/merchant/5829940de18c0f36403b2007">https://www.wish.com/merchant/5829940de18c0f36403b2007</a>	<a href="https://www.wish.com/c/5a9a87a617c7a97974914e7c">https://www.wish.com/c/5a9a87a617c7a97974914e7c</a>	wish.com	7/31/2018
132	yych2010	<a href="https://www.wish.com/merchant/58368df48108914896d3058e">https://www.wish.com/merchant/58368df48108914896d3058e</a>	<a href="https://www.wish.com/c/5a6aeaaad95f79f07083c6434">https://www.wish.com/c/5a6aeaaad95f79f07083c6434</a>	wish.com	7/31/2018
133	guocangmaoyi	<a href="https://www.wish.com/merchant/5affb180f853f45f524740a8">https://www.wish.com/merchant/5affb180f853f45f524740a8</a>	<a href="https://www.wish.com/c/5b24766553d6cc0768b6d137">https://www.wish.com/c/5b24766553d6cc0768b6d137</a>	wish.com	7/31/2018
134	newyangge	<a href="https://www.wish.com/merchant/59c228e7235134421d695fac">https://www.wish.com/merchant/59c228e7235134421d695fac</a>	<a href="https://www.wish.com/c/5af674fa64fef627ca3511ff">https://www.wish.com/c/5af674fa64fef627ca3511ff</a>	wish.com	7/31/2018
135	Hippie's store	<a href="https://www.wish.com/merchant/5866083ba29f44d40f5206a">https://www.wish.com/merchant/5866083ba29f44d40f5206a</a>	<a href="https://www.wish.com/c/5ab078801b3a82117f8b5dee">https://www.wish.com/c/5ab078801b3a82117f8b5dee</a>	wish.com	7/31/2018

# **EXHIBIT 3**

UNITED STATES DISTRICT COURT  
SOUTHERN DISTRICT OF NEW YORK

DOC #  
ELECTRONICALLY FILED  
DOC #  
DATE FILED: 2/5/2019

-----X  
AIRIGAN SOLUTIONS, LLC,

Plaintiff,

v.

YIWU LANHOME JEWELRY CO., LTD.,  
et al.,

Defendants.  
-----X

18-cv-6132 (GHW)

CLERK'S CERTIFICATE  
OF DEFAULT

I, RUBY J. KRAJICK, Clerk of the United States District Court for the Southern District of New York, do hereby certify that this action was commenced on July 6, 2018, with the filing of a summons and complaint, which were subsequently amended, and a copy of the amended summons and amended complaint having been served upon the defendants listed on Attachment A no later than August 3, 2018, by electronic means pursuant to the Court's July 19, 2018, Order authorizing alternate service (Dkt. 43) and proof of service was therefore filed on August 7, 2018 (Dkt. 50). I further certify that the docket entries indicate that the defendants listed on Attachment A have not filed an answer or otherwise moved with respect to the amended complaint herein. The defaults of the defendants listed on Attachment A are hereby noted.

Dated: New York, New York

Feb 5, 2019

RUBY J. KRAJICK  
Clerk of Court

By: 

Deputy Clerk

AIRIGAN SOLUTIONS, LLC v YIWU LANHOME JEWELRY CO., LTD., et al.  
Case No. 18-cv-6132 (GHW)

**Attachment A**

Def No.	Defendant by Seller ID
2	Ningbo Mateyness Household Co., Ltd
6	Ningbo Haishu Greenwell Commodity Industrial Co., Ltd.
9	Yiwu Aliyou Commodity Ltd.
10	Ningbo Jiewei Kitchenware Co., Ltd.
18	StarStar Store
19	CCTX Store
20	MUQGEW
22	Me&My House China Textile Retail Store
33	Hallelujah
37	My SweetHome Store
38	Lucky Yune Store
42	Warm Harbor Store
47	Your assistant Store
48	WOWCC Dropshipping Store
55	Loving Warm Home
57	Sunshine-store
59	Sweet dream family center98
62	CHINA REASARD Store
64	Noachic café Store
65	Aladingding Store
67	SKU Co. Ltd. Store
71	Dolly's Arting Life

Def No.	Defendant by Seller ID
73	Go-Homing Store
74	YY Lucky Store
75	Unique Life Store
76	Sunfei
79	Wishesport
80	SMYTSshop
88	Bui Thi Lan/Labu Store
89	Plotr Oden/ordon.plotr
90	Brad2016
94	zouelbr_0
96	melyodas0
97	best_4youu
98	trustworthy404
100	pacificfantastic
101	silvishop15
102	xcxdianzl
103	nalimat
105	hanoune_9816
106	amal-gadgets-shop
112	fengdingluohua
113	Coolyard
115	gudaobigworld

Def No.	Defendant by Seller ID
116	Mygiftsshop
121	Lilang Da Technology (Lilag Da Technology)
130	jingpinghuadian
132	yych2010
133	guocangmaoyi
134	newyangge

# **EXHIBIT 4**

amazon.com **亚马逊全球开店卖家峰会** 2019最新战略发布+大卖干货分享

2018.12.6 09:30-12:00 **直播现场** **立即预约>>>**

- 👍
- 7
- 💬
- 0
- ★ 📧 🌐

## The new law firm acts as a negotiating NEGG egg stripper, and the multi-platform hundreds of account defendants!



SellerDefense Author: SellerDefense

2018-08-06 16:00:10

Please pay attention to the prevention of the sellers of all platforms, and timely release products with infringement risks!



Two days ago, a friend reported a new case NEGG egg stripper, and the law firm is also new:



Plaintiff Law Firm: Ference & Associates LLC

Plaintiff Law Firm Address: Pennsylvania

Place of prosecution: New York, USA

Prosecution time: 2018/7/6

Defendant seller platform: [Alibaba.com](#) , [AliExpress](#) , [ebay](#) , [Amazon](#) , [Bonanz.com](#) , [walmart](#)

Number of frozen accounts: 135

Brand trademark

The NEGG egg stripper brand trademark registration category is 008 (manual equipment).

# Negg

**Word Mark** NEGG  
**Goods and Services** IC 008, US 023 028 044, G & S: Manually operated device used for peeling eggs. FIRST USE: 20151015. FIRST USI  
**Standard Characters Claimed**  
**Mark Drawing Code** (4) STANDARD CHARACTER MARK  
**Serial Number** 86730673  
**Filing Date** August 25, 2015  
**Current Basis** 1A  
**Original Filing Basis** 1B  
**Published for Opposition** January 19, 2016  
**Registration Number** 5142630  
**Registration Date** February 14, 2017  
**Owner** (REGISTRANT) Margaret Tyler INDIVIDUAL UNITED STATES 105 Dunham Road Fairfield CONNECTICUT 06824  
 (REGISTRANT) Sheila Torgan INDIVIDUAL UNITED STATES 4000 Congress Street Fairfield CONNECTICUT 06824  
 (LAST LISTED OWNER) AIRIGAN SOLUTIONS, LLC LIMITED LIABILITY COMPANY CONNECTICUT 107 JOHN S  
**Assignment Recorded** ASSIGNMENT RECORDED  
**Type of Mark** TRADEMARK  
**Register** PRINCIPAL  
**Live/Dead Indicator** LIVE

 SellerDefense

### List of defendants

Def No.	Defendant by Seller ID	URL of Defendant's Merchant Storefront
1	Yiwu Lanhome Jewelry Co., Ltd.	<a href="https://lanhome.en.alibaba.com/">https://lanhome.en.alibaba.com/</a>
2	Ningbo Mateyness Household Co., Ltd.	<a href="https://mateyness.en.alibaba.com/">https://mateyness.en.alibaba.com/</a>
3	Jiangshan Topme Import & Export Co., Ltd.	<a href="https://tstuoin.en.alibaba.com/">https://tstuoin.en.alibaba.com/</a>
4	Yiwu Joyful Commodity Factory	<a href="https://ywjoyful.en.alibaba.com/">https://ywjoyful.en.alibaba.com/</a>
5	Huizhou Kangning Industrial Co., Ltd.	<a href="https://kangningltd.en.alibaba.com/">https://kangningltd.en.alibaba.com/</a>
6	Ningbo Haishu Greenwell Commodity Industrial Co., Ltd.	<a href="https://nbgreenwell.en.alibaba.com/">https://nbgreenwell.en.alibaba.com/</a>
7	Hefei Fengzhisheng Trade Co., Ltd.	<a href="https://hftzs.en.alibaba.com/">https://hftzs.en.alibaba.com/</a>
8	Ningbo Limkong International Trade Co	<a href="https://limkong.en.alibaba.com/">https://limkong.en.alibaba.com/</a>
9	Yiwu Aliyou Commodity Ltd.	<a href="https://youmall.en.alibaba.com/">https://youmall.en.alibaba.com/</a>
10	Ningbo Jiwei Kitchenware Co., Ltd.	<a href="https://wkitchenware.en.alibaba.com/">https://wkitchenware.en.alibaba.com/</a>
11	Ningbo Shenghui Plastic Technology Co., Ltd.	<a href="https://tech2005.en.alibaba.com/">https://tech2005.en.alibaba.com</a>
12	Shenzhen Vakind Technology Co., Ltd.	<a href="https://vakind.aliexpress.com/store/203288">https://vakind.aliexpress.com/store/203288</a>
13	Pawprint Store	<a href="https://www.aliexpress.com/store/2675065">https://www.aliexpress.com/store/2675065</a>
14	1st kitchen Store	<a href="https://www.aliexpress.com/store/3450001">https://www.aliexpress.com/store/3450001</a>

17	WholeWorld Store	<a href="https://www.aliexpress.com/store/1463728">https://www.aliexpress.com/store/1463728</a>
18	StarStar Store	<a href="https://believe.aliexpress.com/store/2784019">https://believe.aliexpress.com/store/2784019</a>
19	CCTX Store	<a href="https://www.aliexpress.com/store/3363024">https://www.aliexpress.com/store/3363024</a>
20	MUQGEW Pets Store	<a href="https://www.aliexpress.com/store/3243081">https://www.aliexpress.com/store/3243081</a>
21	KitchenMail Store	<a href="https://www.aliexpress.com/store/3402012">https://www.aliexpress.com/store/3402012</a>
22	Me&My House China Textile Retail Store	<a href="https://www.aliexpress.com/store/2227092">https://www.aliexpress.com/store/2227092</a>
23	punkgirl store	<a href="https://www.aliexpress.com/store/1191497">https://www.aliexpress.com/store/1191497</a>
24	Umaru's Houseware Store	<a href="https://www.aliexpress.com/store/2400091">https://www.aliexpress.com/store/2400091</a>
25	Fantasy Garden & Life House Store	<a href="https://www.aliexpress.com/store/2802127">https://www.aliexpress.com/store/2802127</a>
26	My House Store Store	<a href="https://www.aliexpress.com/store/2948247">https://www.aliexpress.com/store/2948247</a>
27	Brunch Lifestyle Store	<a href="https://www.aliexpress.com/store/3239033">https://www.aliexpress.com/store/3239033</a>
28	Transhome Dropshipping Kitchen Store	<a href="https://www.aliexpress.com/store/1713132">https://www.aliexpress.com/store/1713132</a>
29	Believer Store	<a href="https://www.aliexpress.com/store/3676003">https://www.aliexpress.com/store/3676003</a>
30	JOY HOME Mall	<a href="https://www.aliexpress.com/store/1997038">https://www.aliexpress.com/store/1997038</a>
31	MIAONV Store	<a href="https://www.aliexpress.com/store/2885134">https://www.aliexpress.com/store/2885134</a>
32	Dropship Hotsale Store	<a href="https://www.aliexpress.com/store/3617125">https://www.aliexpress.com/store/3617125</a>
33	Hallelujah	<a href="https://www.aliexpress.com/store/326030">https://www.aliexpress.com/store/326030</a>
34	Shanghai Jenny	<a href="https://www.aliexpress.com/store/1971468">https://www.aliexpress.com/store/1971468</a>
35	FLYXF Store	<a href="https://www.aliexpress.com/store/4033097">https://www.aliexpress.com/store/4033097</a>
36	Getyoursave	<a href="https://www.aliexpress.com/store/1491004">https://www.aliexpress.com/store/1491004</a>
37	My SweetHome Store	<a href="https://www.aliexpress.com/store/1656297">https://www.aliexpress.com/store/1656297</a>
38	Lucky Yune Store	<a href="https://www.aliexpress.com/store/3659035">https://www.aliexpress.com/store/3659035</a>
39	Transhome Dropshipping Kitchen Store	<a href="https://www.aliexpress.com/store/1713132">https://www.aliexpress.com/store/1713132</a>
40	Miss U Store	<a href="https://www.aliexpress.com/store/4086007">https://www.aliexpress.com/store/4086007</a>
41	Homey Kitchen Store	<a href="https://www.aliexpress.com/store/2784165">https://www.aliexpress.com/store/2784165</a>
42	Warm Harbor Store	<a href="https://www.aliexpress.com/store/3204067">https://www.aliexpress.com/store/3204067</a>
43	Leading your life Store	<a href="https://www.aliexpress.com/store/2937009">https://www.aliexpress.com/store/2937009</a>
44	Practical Kitchen Store	<a href="https://www.aliexpress.com/store/3111053">https://www.aliexpress.com/store/3111053</a>

 search for 
  Client 
  Chinese station 
  member 
  log in

48	WOWCC Dropshipping Store	<a href="https://www.aliexpress.com/store/1282637">https://www.aliexpress.com/store/1282637</a>
49	AmyHome Store Store	<a href="https://www.aliexpress.com/store/2662193">https://www.aliexpress.com/store/2662193</a>
50	Common Truth	<a href="https://tr.aliexpress.com/store/1380874">https://tr.aliexpress.com/store/1380874</a>
51	VDHJUK Store	<a href="https://tr.aliexpress.com/store/2970028">https://tr.aliexpress.com/store/2970028</a>
52	Umaru's Houseware Store	<a href="https://tr.aliexpress.com/store/2400091">https://tr.aliexpress.com/store/2400091</a>
53	Shop1033157 Store	<a href="https://tr.aliexpress.com/store/1033157">https://tr.aliexpress.com/store/1033157</a>
54	Best Home lifestyle	<a href="https://tr.aliexpress.com/store/2022020">https://tr.aliexpress.com/store/2022020</a>
55	Loving Warm Home	<a href="https://tr.aliexpress.com/store/237015">https://tr.aliexpress.com/store/237015</a>
56	TOPATY Store	<a href="https://tr.aliexpress.com/store/3174028">https://tr.aliexpress.com/store/3174028</a>
57	Sunshine-store	<a href="https://tr.aliexpress.com/store/407893">https://tr.aliexpress.com/store/407893</a>
58	Leading lifestyle store	<a href="https://tr.aliexpress.com/store/1359042">https://tr.aliexpress.com/store/1359042</a>
59	Sweet dream family center98	<a href="https://tr.aliexpress.com/store/1752437">https://tr.aliexpress.com/store/1752437</a>
60	Poodle XiaoCoCos Shop Store	<a href="https://he.aliexpress.com/store/3508046">https://he.aliexpress.com/store/3508046</a>
61	Innovation Drinkware Store	<a href="https://www.aliexpress.com/store/3106052">https://www.aliexpress.com/store/3106052</a>
62	CHINA REASARD Store	<a href="https://www.aliexpress.com/store/1440008">https://www.aliexpress.com/store/1440008</a>
63	Enjoys Life Store	<a href="https://www.aliexpress.com/store/2947149">https://www.aliexpress.com/store/2947149</a>
64	Noachio café Store	<a href="https://he.aliexpress.com/store/3178001">https://he.aliexpress.com/store/3178001</a>
65	Aladingding Store	<a href="https://www.aliexpress.com/store/3630083">https://www.aliexpress.com/store/3630083</a>
66	Institute of Food	<a href="https://www.aliexpress.com/store/1868025">https://www.aliexpress.com/store/1868025</a>
67	SKU Co., Ltd. Store	<a href="https://www.aliexpress.com/store/2344160">https://www.aliexpress.com/store/2344160</a>
68	sweethome-sale	<a href="https://www.aliexpress.com/store/1656297">https://www.aliexpress.com/store/1656297</a>
69	Fashion Store A8	<a href="https://www.aliexpress.com/store/1907984">https://www.aliexpress.com/store/1907984</a>
70	Worldwide Dropshipping Store	<a href="https://www.aliexpress.com/store/3204074">https://www.aliexpress.com/store/3204074</a>
71	Dolly's Arting Life	<a href="https://www.aliexpress.com/store/2348069">https://www.aliexpress.com/store/2348069</a>
72	goodfeer-Store	<a href="https://www.aliexpress.com/store/3359003">https://www.aliexpress.com/store/3359003</a>
73	Go-Homing Store	<a href="https://www.aliexpress.com/store/2665213">https://www.aliexpress.com/store/2665213</a>
74	YY Luckly Store	<a href="https://www.aliexpress.com/store/3883028">https://www.aliexpress.com/store/3883028</a>
75	Unique Life Store	<a href="https://tr.aliexpress.com/store/3567033">https://tr.aliexpress.com/store/3567033</a>
76	Sunfei	<a href="https://www.amazon.com/s?merchant=A1ATFV8UIG2">https://www.amazon.com/s?merchant=A1ATFV8UIG2</a>
77	Some Interesting Store	<a href="https://www.amazon.com/s?merchant=A1V8U5HSZCRF">https://www.amazon.com/s?merchant=A1V8U5HSZCRF</a>
78	Ziftei	<a href="https://www.amazon.com/s?merchant=A3O0Y12PH5KA">https://www.amazon.com/s?merchant=A3O0Y12PH5KA</a>
79	Wishesport	<a href="https://www.amazon.com/s?merchant=A1EB9Q825KP">https://www.amazon.com/s?merchant=A1EB9Q825KP</a>
80	SMYTShop	<a href="https://www.amazon.com/SMYTShop/b/ref=bl_dp_web_1722738501?ie=UTF8&amp;node=1722738501&amp;d=lbl_brands_browse-bin=SMYTShop">https://www.amazon.com/SMYTShop/b/ref=bl_dp_web_1722738501?ie=UTF8&amp;node=1722738501&amp;d=lbl_brands_browse-bin=SMYTShop</a>
..	..	<a href="https://www.amazon.com/s?merchant=A24E40OA">https://www.amazon.com/s?merchant=A24E40OA</a>

search for Client Chinese station member log in

84	Brandon Trollpoe	<a href="https://www.amazon.com/s?merchant=A2UF2EWA1RAZI">https://www.amazon.com/s?merchant=A2UF2EWA1RAZI</a>
85	HoLeis	<a href="https://www.amazon.com/s?merchant=A22H8OF86FF">https://www.amazon.com/s?merchant=A22H8OF86FF</a>
86	TiLarry	<a href="https://www.amazon.com/s?merchant=A2W9F9D165XVL">https://www.amazon.com/s?merchant=A2W9F9D165XVL</a>
87	HOMEFUL	<a href="https://www.amazon.com/Homeful/b/ref=wl_bk_id_web_15180153011?ie=UTF8&amp;node=15180153011&amp;field-lbr_brands_browse-bin=Homeful">https://www.amazon.com/Homeful/b/ref=wl_bk_id_web_15180153011?ie=UTF8&amp;node=15180153011&amp;field-lbr_brands_browse-bin=Homeful</a>
88	Labu Store	<a href="https://www.amazon.com/s?merchant=A1EFTOGAWG4Z5">https://www.amazon.com/s?merchant=A1EFTOGAWG4Z5</a>
89	ordon.piotr	<a href="https://www.amazon.com/s?merchant=A3H540WT3SRHB">https://www.amazon.com/s?merchant=A3H540WT3SRHB</a>
90	Brad2016	<a href="https://www.dhgate.com/store/20127433">https://www.dhgate.com/store/20127433</a>
91	dhgate_factory01	<a href="https://www.dhgate.com/store/20644561">https://www.dhgate.com/store/20644561</a>
92	dhgatetop_merchant	<a href="https://www.dhgate.com/store/20748377">https://www.dhgate.com/store/20748377</a>
93	greattseller	<a href="https://www.ebay.com/usr/greattseller">https://www.ebay.com/usr/greattseller</a>
94	zouelbr_0	<a href="https://www.ebay.com/usr/zouelbr_0">https://www.ebay.com/usr/zouelbr_0</a>
95	2017junmei	<a href="https://www.ebay.com/usr/2017junmei">https://www.ebay.com/usr/2017junmei</a>
96	melvodos0	<a href="https://www.ebay.com/usr/melvodos0">https://www.ebay.com/usr/melvodos0</a>
97	best_4youu	<a href="https://www.ebay.com/usr/best_4youu">https://www.ebay.com/usr/best_4youu</a>
98	trustworthy404	<a href="https://www.ebay.com/usr/trustworthy404">https://www.ebay.com/usr/trustworthy404</a>
99	2015ilbruc	<a href="https://www.ebay.com/usr/2015ilbruc">https://www.ebay.com/usr/2015ilbruc</a>
100	pacificfantastic	<a href="https://www.ebay.com/usr/pacificfantastic">https://www.ebay.com/usr/pacificfantastic</a>
101	silvishop15	<a href="https://www.ebay.com/usr/silvishop15">https://www.ebay.com/usr/silvishop15</a>
102	xcdianzi	<a href="https://www.ebay.com/usr/xcdianzi">https://www.ebay.com/usr/xcdianzi</a>
103	nalimat	<a href="https://www.ebay.com/usr/nalimat">https://www.ebay.com/usr/nalimat</a>

 search for  
 Client  
 Chinese station  
 member  
 log in

104	kitsimple sale	<a href="https://www.ebay.com/usr/kitsimple sale">https://www.ebay.com/usr/kitsimple sale</a>
105	hanoune_9816	<a href="https://www.ebay.com/usr/hanoune_9816">https://www.ebay.com/usr/hanoune_9816</a>
106	amal-gadgets-shop	<a href="https://www.ebay.com/usr/amal-gadgets-shop">https://www.ebay.com/usr/amal-gadgets-shop</a>
107	ultimate1seller	<a href="https://www.ebay.com/usr/ultimate1seller">https://www.ebay.com/usr/ultimate1seller</a>
108	yihangjc	<a href="https://www.ebay.com/usr/yihangjc">https://www.ebay.com/usr/yihangjc</a>
109	cqfgrs	<a href="https://www.ebay.com/usr/cqfgrs">https://www.ebay.com/usr/cqfgrs</a>
110	qwwdss	<a href="https://www.ebay.com/usr/qwwdss">https://www.ebay.com/usr/qwwdss</a>
111	HENGCHU	<a href="https://www.wish.com/merchant/555dc368896deca8e">https://www.wish.com/merchant/555dc368896deca8e</a>
112	fengdingluohua	<a href="https://www.wish.com/merchant/58ccad88fa64c0098">https://www.wish.com/merchant/58ccad88fa64c0098</a>
113	Coolyard	<a href="https://www.wish.com/merchant/5a994e0b1ef67d0dc">https://www.wish.com/merchant/5a994e0b1ef67d0dc</a>
114	vakind2018	<a href="https://www.wish.com/merchant/5374509f76b25f8fb">https://www.wish.com/merchant/5374509f76b25f8fb</a>
115	gudaobigworld	<a href="https://www.wish.com/merchant/58256ca2291f66f6c">https://www.wish.com/merchant/58256ca2291f66f6c</a>
116	Mygiftshop	<a href="https://www.wish.com/merchant/5800b5517d23f319">https://www.wish.com/merchant/5800b5517d23f319</a>
117	PowerMup	<a href="https://www.wish.com/merchant/59e7f8e20a79688a0">https://www.wish.com/merchant/59e7f8e20a79688a0</a>
118	WildLion	<a href="https://www.wish.com/merchant/5a9e6935bc287c15">https://www.wish.com/merchant/5a9e6935bc287c15</a>
119	youncedit	<a href="https://www.wish.com/merchant/5a167cb209a98d54">https://www.wish.com/merchant/5a167cb209a98d54</a>
120	AdventureHelper	<a href="https://www.wish.com/merchant/5a9e1b57be5addc06">https://www.wish.com/merchant/5a9e1b57be5addc06</a>
121	Lilang Da Technology	<a href="https://www.wish.com/merchant/586b8ae88565934047">https://www.wish.com/merchant/586b8ae88565934047</a>
122	Unbeatable sale.com	<a href="https://www.wish.com/merchant/5877e44ba8491f32e">https://www.wish.com/merchant/5877e44ba8491f32e</a>
123	treebackwe18	<a href="https://www.wish.com/merchant/5954a16547e41e7fa">https://www.wish.com/merchant/5954a16547e41e7fa</a>
124	Fashion-Master	<a href="https://www.wish.com/merchant/54815a624abe61d30">https://www.wish.com/merchant/54815a624abe61d30</a>
125	Rogerww	<a href="https://www.wish.com/merchant/577cd7d7bc1f126da">https://www.wish.com/merchant/577cd7d7bc1f126da</a>
126	PowerMup	<a href="https://www.wish.com/merchant/59e7f8e20a79688a0">https://www.wish.com/merchant/59e7f8e20a79688a0</a>
127	coverreverse	<a href="https://www.wish.com/merchant/53426c2b726ed3120">https://www.wish.com/merchant/53426c2b726ed3120</a>
128	Embroidered shop	<a href="https://www.wish.com/merchant/587363c694a84b189">https://www.wish.com/merchant/587363c694a84b189</a>
129	moraltop	<a href="https://www.wish.com/merchant/55d3e4bf9242fd66cc4">https://www.wish.com/merchant/55d3e4bf9242fd66cc4</a>
130	jingpinghuadian	<a href="https://www.wish.com/merchant/5ac9c4952fb95f847f">https://www.wish.com/merchant/5ac9c4952fb95f847f</a>
131	themarvel	<a href="https://www.wish.com/merchant/5829940de1403b2007">https://www.wish.com/merchant/5829940de1403b2007</a>
132	yych2010	<a href="https://www.wish.com/merchant/58368d481096d3058e">https://www.wish.com/merchant/58368d481096d3058e</a>
133	guocangmaoyi	<a href="https://www.wish.com/merchant/5aff8180f854740a8">https://www.wish.com/merchant/5aff8180f854740a8</a>
134	newyangge	<a href="https://www.wish.com/merchant/59c228a7231d69f5ac">https://www.wish.com/merchant/59c228a7231d69f5ac</a>
135	Hippie's store	<a href="https://www.wish.com/merchant/587363c694a84b189">https://www.wish.com/merchant/587363c694a84b189</a>

Publication example

Hi cheng (Sign in) | Daily Deals | Gift Cards | Help & Contact

ebay Shop by category

NEGG Related: egg peeler, negg egg peeler

Categories: All, Home & Garden, Fruit & Vegetable Peelers, Collectibles, Liberty Field Collectibles, More...

Color: 390 all  
 Black (7)  
 Green (5)  
 Pink (5)  
 Red (14)  
 White (5)  
 Yellow (10)

Guaranteed Delivery: see all  
 No Preference  
 1 day shipping  
 2 day shipping  
 3 day shipping  
 4 day shipping



Condition: see all  
 New (76)  
 Used (11)

Price: \$ - \$

Buying Format: see all  
 All Listings (87)  
 Accepts Offers (2)  
 Auction (1)

87 results Save this search

Did you mean: negg (200,438 items)?

 <b>The Negg Yellow By Airigan Solutions Egg Peeler Hard Boiled...</b> ★★★★★ (7) <b>\$17.95</b> List price: \$49.99 Buy it Now Free Shipping 78 Sold	 <b>The Negg White By Airigan Solutions Egg Peeler Hard Boiled...</b> ★★★★★ (1) <b>\$17.95</b> List price: \$49.99 Buy it Now Free Shipping 71 Sold	 <b>The Negg Fuchsia By Airigan Solutions Egg Peeler Hard Boiled...</b> ★★★★★ (1) <b>\$17.95</b> List price: \$49.99 Buy it Now Free Shipping 31 Sold	SPONSORED <b>THE NEGG BOILED EGG PEELER</b> <b>\$23.04</b> Buy it Now Free Shipping
--	---	---	---

Buyer Defense

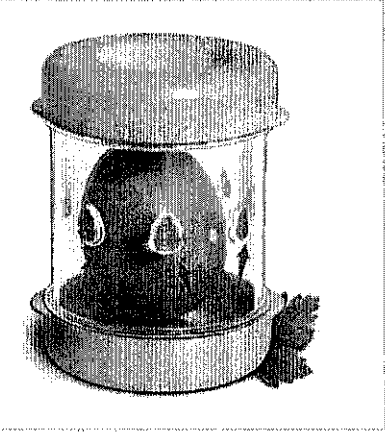

**The Negg Yellow By Airigan Solutions Egg Peeler Hard Boiled NIB**  
 ★★★★★ (7) product ratings

Condition: New  
 Quantity: 1 More than 10 available / 78 sold

List price: \$49.99  
 You save: \$32.04 (64% off)  
 Now: **US \$17.95**

Buy it Now  
 Add to cart  
 Add to watch list

100% buyer satisfaction 78 sold More than 82% sold

Shipping: FREE Standard Shipping | See details  
 Item location: Uxio, Michigan, United States  
 Ships to: Worldwide | See exclusions

Delivery: Estimated between Mon, Aug. 6 and Wed, Aug. 10

Payments: PayPal VISA M/C Discover  
 Credit Cards processed by PayPal



**The Negg Hard Boiled Egg Peeler Plastic 1 pk**  
 ★★★★★ (10) product ratings

Condition: New  
 Quantity: 1 More than 10 available / 109 sold / See feedback

List price: \$29.94  
 You save: \$12.05 (40% off)  
 Now: **US \$17.95**

Buy it Now  
 Add to cart  
 Add to watch list

100% buyer satisfaction 109 sold More than 82% sold

Shipping: FREE Standard Shipping | See details  
 Item location: Sacramento, California, United States  
 Ships to: United States | See exclusions

Delivery: Estimated between Wed, Aug. 9 and Wed, Aug. 15

to sum up

The shape of the NEGG egg stripper is quite special, using several points on the wall of the cup to impact the shell. The defendant's publication is obviously infringing:

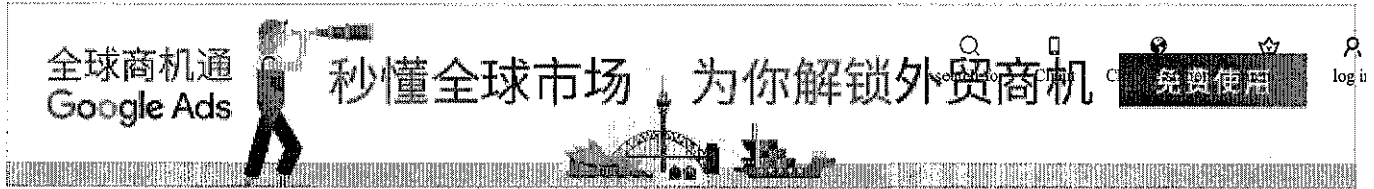

This article is included in the following orchard

[see more >](#)



[Amazon](#) Cross-border community

Skills and sales, cautious anti-association, economic use of FBA, and how to increase the amount of interaction with the big sale.

[Entering the orchard](#)



[eBay](#) Cross-border community

Professional lecturers guide the opening of the store, the industry's big coffee teaches skills, the off-season is the peak season, the secrets are here.

[Entering the orchard](#)

This article has been collected in:

[Amazon](#)

[eBay](#)

[AliExpress](#)

[Alibaba](#)

[Walmart](#)

[Bonanza](#)

[Platform news](#)

[Infringement](#)

[Intellectual property](#)

[Export e-commerce](#)



7



0 comments



0 collection

share to:



related information



Rain class super member



Keith four combos! Frozen the pigs and PJMask infringing sellers, and also the new agent brand PETSROCK



又一波Wish卖家资金被冻结！担心这个美国潮牌Off-White



指尖猴子诉状分析，这2种玩具也被保护不能卖！



EPS刚告完eBay，又转战Wish！还是TOUCH系列产品...



又一波速卖通卖家中招！小心这款宠物手套

推荐优品查看更多 >



安心出行常备款，车载宠物安全带  
现货1件起订

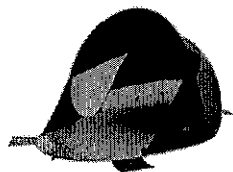

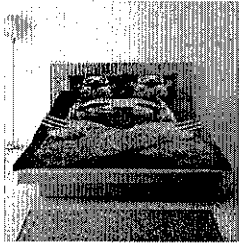

水晶绒印花，儿童床上三件套  
一件来图定制



亚马逊爆款智能手环，可防水防尘  
运动计步“神器”



[推荐服务查看更多>](#)



雨课 最强讲师团  
为你传道/授业/解惑

雨课年度会员 尊享全年好课  
讲师团来袭 助力卖家成长

¥3998 ~~¥5998~~

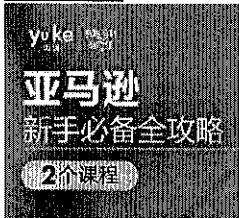

亚马逊新手必备全攻略 (2个课程)

亚马逊新手入门必备

¥488 ~~¥3078~~

cifnews 雨果网 雨果黄金会员产品

# 雨果一助

已加入企业

¥30000.00-¥50000.00



Client Chinese station member log in

多语言&小语种网站模板制作-免费试用  
一键自建站，再赠送86节外贸营销推广课

¥2900.00¥

评论  
登录后评论

欢迎留言交流

发布

最新活动查看更多 >

明日14点30分

Shopify品牌出海交流会—官方答疑解惑

周一9点30分

2018Wish年度卖家峰会

周二晚8点

走进中东蓝海市场，盘点网购畅销品类

周四至周五

直击现场！亚马逊全球开店卖家峰会！

Home Selection service Rain class Live broadcast activity More

Cross-border e-commerce intelligent service platform



热门标签

[中美贸易战](#)

[年终旺季](#)

[全球开店](#)

[VAT](#)

[外贸转型](#)

[亚马逊美国站](#)

[一带一路](#)

[亚马逊英国站](#)

[开发信](#)

[Wish旺季操作](#)

订阅每周精选

请输入邮箱地址

雨果网

亚马逊

eBay

热门文章

最新文章

[They did content marketing, and the results were all smashed ... 2018-09-20 09:06:00](#) Starting from 0, the monthly sales of 8 million, she lived in the "Amazon" to live a wonderful 2018-09-19 15:22:00 Restore Amazon BestSeller Peer Listing Modify details, too powerful! 2018-09-13 15:39:00 5 stars on Amazon, hot-selling products, your next explosion is here 2018-09-16 09:54:00 Amazon's most successful 20 selections in history, see through Explosion models to create rules! 2018-08-22 09:31:00

[Previous](#)

[SEO: How do you get traffic on a new e-commerce website in the early days?](#)

2018-08-06 15:50:51

[Next](#)

[Amazon releases the sales restrictions for toys and games in the year-end season. Do you meet the requirements of the seller?](#)

2018-08-06 16:05:11

[Home](#) [Selection](#) [service](#) [Rain class](#) [Live broadcast](#) [activity](#) [More](#)

Cross-border e-commerce intelligent service platform

[join us](#)

[Partner](#)

[CCEE selection](#)



[Chinese station](#)

[member](#)

[log in](#)

[Explosive submission](#)

[Exhibition cooperation](#)

[Hugo Orchard](#)

[Rain class business school](#)

[Feedback](#)

[Observer program](#)

©2013 Hugo Net 闽ICP备11004599号-1



I want to break the news



Download App



Feedback

X

输入邮箱或手机号码

Please fill in your mobile phone number or email address correctly!

这里输入文字...

Please enter content  
send



Scan QR code to  
download Hugo Network APP

# **EXHIBIT 5**

Jason M. Drangel (JD 7204)  
[idrangel@ipcounselors.com](mailto:idrangel@ipcounselors.com)  
Ashly E. Sands (AS 7715)  
[asands@ipcounselors.com](mailto:asands@ipcounselors.com)  
Spencer Wolfgang (SW 2389)  
[swolfgang@ipcounselors.com](mailto:swolfgang@ipcounselors.com)  
Mary Kate Brennan (MB 5595)  
[mbrennan@ipcounselors.com](mailto:mbrennan@ipcounselors.com)  
Brienne Scully (BS 3711)  
[bscully@ipcounselors.com](mailto:bscully@ipcounselors.com)  
EPSTEIN DRANGEL LLP  
60 East 42<sup>nd</sup> Street, Suite 2520  
New York, NY 10165  
Telephone: (212) 292-5390  
Facsimile: (212) 292-5391  
*Attorneys for Plaintiff*  
*Mattel, Inc.*

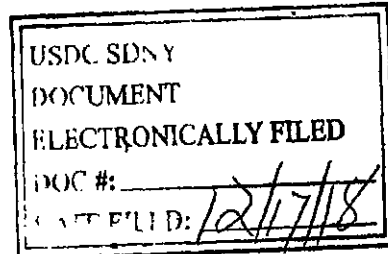

UNITED STATES DISTRICT COURT  
SOUTHERN DISTRICT OF NEW YORK

MATTEL, INC.,

*Plaintiff*

v.

86755, 2008HAPPYSTORE, 222STORE, 8126N\_55,  
91STORE, 922SHOP, ACG168, ARKO\_SUMON,  
AUTOPARTS1989, AZJ\_587, BEST4CHOOSE,  
BESTATEAM, BESTSELLFORSP-A,  
BEYOND\_1989, BIGMOUSE31, BILL-18187,  
BIOSSPORT, BOY2MAN-DO, CKERA-UTIMI,  
CN2015\_WUXI, COSPLAY\*STORE,  
CRAZYCOMMERCE000, CSDF4511IN,  
CUPPACOFFEE TRADE, CXX128,  
CY\_FRANKONLY, CY\_MONSTERS, CYGG-2013,  
DIGITSELL3, DIVING, DOLLAR17, ELSA\*2014\*,  
ENTERINTOWORLD2010, EPAY333, FACTORTY-  
WHOLESALE888, FRANKYU205,  
GLOBALBUSINESS1987, HK-ELECTRONIC2010,  
HUXUANBAR, IVITA\_FACTORY2018,  
JUSTEPEAN, KAPUYONG, LAN-YRD, LINHZEMI,  
LIWED-0, LONGOUTDOOR402, LUZH2012,  
MAGIC CITY288, MISSQUEEN1987,

CIVIL ACTION No.  
18-cv-8825 (JSR)

**AMENDED [PROPOSED] *JS***  
**FINAL DEFAULT**  
**JUDGMENT AND**  
**PERMANENT INJUNCTION**  
**ORDER**

MOTORPARTS1990, MOU2B, MYHOMESTORY96,  
NANKYMALL, NEVCO3, OO\_875, PINLAND211,  
SENIOR\_SHOP20176, SEOSEEDI, SHMALL18,  
SMARTMALL99, SNAIL8023, STAR\_TOYS2016,  
STRONG-STOCK, STRONGAPPLE2015,  
SUPER2010SHOP, SUPERSUNSTAR,  
SWANBSY870810, TOP1\*TOYS,  
TOYS2015WHOLESALE, VDG4SD1S,  
VERASTORE01, WONDERFULFEEL, XJZU,  
YANYANYUE\_20160, YAOUE, YUNYAN2016,  
ZHAHENGFE0, ZHENDUO006 and ZONG-HK,

*Defendants*

This matter comes before the Court upon Motion by Plaintiff Mattel, Inc. (“Plaintiff” or “Mattel”) for the entry of a final judgment and permanent injunction by default against the following Defendants: 2008happystore, 222store, 8126n\_55, 86755, 91store, 922shop, acg168, arko\_sumon, autoparts1989, azj\_587, Biossport, bestateam, bestsellforsp-a, beyond\_1989, bigmouse31, bill-18187, boy2man-do, ckera-utimi, cn2015\_wuxi, crazycommerce000, csdf4511in, cuppacoffeetrade, cck128, cy\_frankonly, cy\_monsters, cygg-2013, digitsell3, diving, dollar17, elsa\*2014\*, epay333, globalbusiness1987, hk-electronic2010, ivita\_factory2018, kapuyong, lan-yrd, linhzemi, liwed-0, Longoutdoor402, luzh2012, motorparts1990, mou2b, myhomestory96, nevco3, oo\_875, pinland211, seoseedi, shmall18, smartmall99, snail8023, strong-stock, strongapple2015, super2010shop, supersunstar, swanbsy870810, top1\*toys, vdg4sd1s, verastore01, wonderfulfeel, yanyanyue\_20160, yaoue, yunyan2016, zhahengfe0 and zong-hk (collectively hereinafter referred to as “Defaulting Defendants”) for Defaulting Defendants’ trademark infringement, trademark counterfeiting, false designation of origin, passing off, unfair competition, copyright infringement and related state and common law claims arising out of Defaulting Defendants’ unauthorized use of Plaintiff’s UNO Marks and UNO Works, without

limitation, in their manufacturing, importing, exporting, advertising, marketing, promoting, distributing, displaying offering for sale and/or selling offering for sale and/or sale of Counterfeit Products and/or Infringing Products.<sup>1</sup>

The Court, having considered the Memorandum of Law and Affidavit of Mary Kate Brennan in support of Plaintiff's Motion for Default Judgment and a Permanent Injunction ("Motion for Default Judgment"), the Certificate of Service of the Summons and Complaint, the Certificate of the Clerk of the Court stating that no answer has been filed in the instant action ("Action"), and upon all other pleadings and papers on file in this Action, it is hereby ORDERED, ADJUDGED AND DECREED as follows (hereinafter, "Default Judgment Order"):

**I. Defaulting Defendants' Liability**

- 1) Judgment is granted in favor of Plaintiff on all claims asserted against Defaulting Defendants in the Complaint;

**II. Damages Awards**

- 1) IT IS FURTHER ORDERED, ADJUDGED AND DECREED, that because it would serve both the compensatory and punitive purposes of the Lanham Acts' prohibitions on willful infringement, and because Plaintiff has sufficiently set forth the basis for the statutory damages award requested in its Motion for Default Judgment and a Permanent Injunction, the Court finds such an award to be reasonable and Plaintiff is awarded statutory damages against each of the Defaulting Defendants pursuant to Section 15 U.S.C. § 1117(c) of the Lanham Act as follows, plus post-judgment interest:

---

<sup>1</sup> Where a defined term is referenced herein and not defined herein, the defined term should be understood as it is defined in the Complaint, Application or Glossary.

DEFAULTING DEFENDANT	STATUTORY DAMAGES REQUESTED
222store	\$ 50,000.00
8126n_55	\$ 50,000.00
acg168	\$ 50,000.00
arko_sumon	\$ 50,000.00
azj_587	\$ 50,000.00
Biossport	\$ 50,000.00
bigmouse31	\$ 50,000.00
bill-18187	\$ 50,000.00

ckera-utimi	\$	50,000.00
csdf4511in	\$	50,000.00
cuppacoffeetrade	\$	50,000.00
ckk128	\$	50,000.00
cy_frankonly	\$	50,000.00
cy_monsters	\$	50,000.00
digitsell3	\$	50,000.00
ivita_factory2018	\$	50,000.00
kapuyong	\$	50,000.00

linhzemi	\$	50,000.00
liwed-0	\$	50,000.00
Longoutdoor402	\$	50,000.00
luzh2012	\$	50,000.00
motorparts1990	\$	50,000.00
oo_875	\$	50,000.00
seoseedi	\$	50,000.00
shmall18	\$	50,000.00
smartmall99	\$	50,000.00

super2010shop	\$	50,000.00
supersunstar	\$	50,000.00
top1*toys	\$	50,000.00
verastore01	\$	50,000.00
yanyanyue_20160	\$	50,000.00
yaoue	\$	50,000.00
yunyan2016	\$	50,000.00
zhahengfe0	\$	50,000.00
zong-hk	\$	50,000.00

bestateam	\$	75,000.00
beyond_1989	\$	75,000.00
myhomestory96	\$	75,000.00
nevco3	\$	75,000.00
strongapple2015	\$	75,000.00
swanbsy870810	\$	75,000.00
bestsellforsp-a	\$	100,000.00
crazycommerce000	\$	100,000.00
vdg4sdls	\$	100,000.00

cn2015_wuxi	\$	125,000.00
dollar17	\$	125,000.00
86755	\$	150,000.00
autoparts1989	\$	150,000.00
mou2b	\$	150,000.00
wonderfulfeel	\$	150,000.00
globalbusiness1987	\$	200,000.00
lan-yrd	\$	200,000.00
922shop	\$	250,000.00

cygg-2013	\$	250,000.00
diving	\$	250,000.00
hk-electronic2010	\$	250,000.00
snail8023	\$	250,000.00
strong-stock	\$	250,000.00
2008happystore	\$	300,000.00
elsa*2014*	\$	300,000.00
epay333	\$	300,000.00
91store	\$	400,000.00

boy2man-d	\$ 400,000.00
pinland211	\$ 500,000.00

**III. Permanent Injunction**

1) IT IS FURTHER ORDERED, ADJUDGED AND DECREED, that Defaulting Defendants, their respective officers, agents, servants, employees, successors and assigns and all persons acting in concert with or under the direction of Defaulting Defendants (regardless of whether located in the United States or abroad), who receive actual notice of this Order are permanently enjoined and restrained from:

- A. manufacturing, importing, exporting, advertising, marketing, promoting, distributing, displaying, offering for sale, selling and/or otherwise dealing in Counterfeit Products or any other products bearing the UNO Marks and/or marks that are confusingly similar to, identical to and constitute a counterfeiting and/or infringement of the UNO Marks and/or incorporating the UNO Works and/or artwork that is substantially similar to, identical to and constitute infringement of the UNO Works;
- B. directly or indirectly infringing in any manner any of Plaintiff's trademarks, copyrights or other rights (whether now in existence or hereafter created) including, without limitation, the UNO Marks and UNO Works;
- C. using any reproduction, counterfeit, copy or colorable imitation of Plaintiff's trademarks, copyrights or other rights (whether now in existence or hereafter created)

including, without limitation, the UNO Marks and UNO Works to identify any goods or services not authorized by Plaintiff;

- D. using any of Plaintiff's trademarks, copyrights or other rights (whether now in existence or hereafter created) including, without limitation, the UNO Marks and UNO Works, or any other marks or artwork that are confusingly or substantially similar to the UNO Marks and UNO Works on or in connection with Defaulting Defendants' manufacturing, importing, exporting, advertising, marketing, promoting, distributing, displaying, offering for sale, selling and/or otherwise dealing in the Counterfeit Products and/or Infringing Products;
- E. using any false designation of origin or false description, or engaging in any action which is likely to cause confusion, cause mistake and/or to deceive members of the trade and/or the public as to the affiliation, connection or association of any product manufactured, imported, exported, advertised, marketed, promoted, distributed, displayed, offered for sale or sold by Defaulting Defendants with Plaintiff, and/or as to the origin, sponsorship or approval of any product manufactured, imported, exported, advertised, marketed, promoted, distributed, displayed, offered for sale or sold by Defaulting Defendants and Defaulting Defendants' commercial activities by Plaintiff;
- F. secreting, concealing, destroying, altering, selling off, transferring or otherwise disposing of and/or dealing with: (i) Counterfeit Products; (ii) any computer files, data, business records, documents or any other records or evidence relating to:
  - i. any and all websites and/or accounts held by or associated with Defaulting Defendants, their respective officers, employees, agents, servants and all persons in active concert or participation with any of

them ("User Accounts") and/or Defaulting Defendants' User Accounts through which Defaulting Defendants, their respective officers, employees, agents, servants and all persons in active concert or participation with any of them manufacture, import, export, advertise, market, promote, distribute, offer for sale, sell and/or otherwise deal in products, including the Counterfeit Products, which are held by or associated with Defaulting Defendants, their respective officers, employees, agents, servants and all persons in active concert or participation with any of them ("Merchant Storefront(s)");

- j. Defaulting Defendants' Assets (as defined *infra*), and
- k. the manufacture, importation, exportation, advertising, marketing, promotion, distribution, display, offering for sale and/or sale of Counterfeit Products by Defaulting Defendants and by their respective officers, employees, agents, servants and all persons in active concert or participation with any of them; and

G. effecting assignments or transfers, forming new entities or associations, or creating and/or utilizing any other platform, User Accounts, Merchant Storefronts or any other means of importation, exportation, advertising, marketing, promotion, distribution, display, offering for sale and/or sale of Counterfeit Products for the purposes of circumventing or otherwise avoiding the prohibitions set forth in this Default Judgment Order.

- 2) IT IS FURTHER ORDERED, ADJUDGED AND DECREED that eBay, Inc., PayPal Inc. ("PayPal"), Payoneer Inc. ("Payoneer") and PingPong Global Solutions, Inc. ("PingPong")

(eBay, PayPal, Payoneer and PingPong are collectively referred to as the “Financial Institutions”) are permanently enjoined and restrained from:

- A. secreting, concealing, transferring, disposing of, withdrawing, encumbering or paying any money, securities or other property or assets of Defaulting Defendants (whether said assets are located in the U.S. or abroad) (“Defaulting Defendants’ Assets”) from or to accounts associated with or utilized by any Defaulting Defendant or any Defaulting Defendants’ User Accounts or Merchant Storefronts (whether said account is located in the U.S. or abroad) (“Defaulting Defendants’ Financial Accounts”) until further ordered by this Court;
  - B. secreting, concealing, destroying, altering, selling off, transferring or otherwise disposing of and/or dealing with any computer files, data, business records, documents or any other records or evidence relating to Defendants’ Assets and Defendants’ Financial Accounts; and
  - C. knowingly instructing, aiding or abetting any other person or business entity in engaging in any of the activities referred to in subparagraphs III(1)(A) through III(1)(G) and III(2)(A) through III(2)(B) above and III(3)(A) below.
- 3) IT IS FURTHER ORDERED, ADJUDGED AND DECREED that eBay is permanently enjoined and restrained from:
- A. providing services to Defaulting Defendants and Defaulting Defendants’ User Accounts and Merchant Storefronts, including, without limitation, continued operation of Defaulting Defendants’ User Accounts and Merchant Storefronts; and

- B. knowingly instructing, aiding or abetting any other person or business entity in engaging in any of the activities referred to in subparagraphs III(1)(A) through III(1)(G) and III(2)(A) through III(2)(B) above and III(3)(A) above.
- 4) IT IS FURTHER ORDERED, ADJUDGED AND DECREED that Defaulting Defendants must deliver up for destruction to Plaintiff any and all Counterfeit Products and any and all packaging, labels, tags, advertising and promotional materials and any other materials in the possession, custody or control of Defaulting Defendants that infringe any of Plaintiff's trademarks, copyrights or other rights including, without limitation, the UNO Marks or UNO Works, or bear any marks that are confusingly or substantially similar to the UNO Marks and UNO Works pursuant to 15 U.S.C. § 1118;

**IV. Post-Judgment Asset Transfer and Asset Freeze Order**

- 1) IT IS FURTHER ORDERED, ADJUDGED AND DECREED that in accordance with Rule 64 of the Federal Rules of Civil Procedure, 15 U.S.C. § 1116(a) and this Court's inherent equitable powers to issue remedies ancillary to its authority to provide final relief, and given the difficulties Plaintiff would have enforcing this Default Judgment Order, Defaulting Defendants' Assets from Defaulting Defendants' Financial Accounts that were and/or are attached and frozen or restrained pursuant to the TRO and/or PI Order, or which are attached and frozen or restrained pursuant to any future order entered by the Court in this Action, (collectively, "Defaulting Defendants' Frozen Assets" and "Defaulting Defendants' Frozen Accounts," respectively), are, to the extent that a given Defaulting Defendant's Frozen Assets equal Defaulting Defendants' Individual Damages Award, hereby released and transferred to Plaintiff as full satisfaction of Defaulting Defendants' Individual Damages Award for that Defaulting Defendant, and those Defaulting Defendant's Frozen Assets shall be transferred to

Plaintiff through Plaintiff's counsel forthwith, and upon receipt by Plaintiff's counsel of such Defaulting Defendant's Frozen Assets in full satisfaction of Defaulting Defendants' Individual Damages Award, the Financial Institution(s) holding that Defaulting Defendant's Frozen Assets and Defaulting Defendants' Frozen Accounts may unfreeze that Defaulting Defendant's Frozen Assets and Defaulting Defendant's Frozen Accounts. To the extent that a Defaulting Defendant's Frozen Assets are less than Defaulting Defendants' Individual Damages Award, that Defaulting Defendant's Frozen Assets are hereby released and transferred to Plaintiff as partial satisfaction of Defaulting Defendants' Individual Damages Award for that Defaulting Defendant and those Defaulting Defendant's Frozen Assets shall be transferred to Plaintiff through Plaintiff's counsel forthwith, and

- 2) IT IS FURTHER ORDERED, ADJUDGED AND DECREED that in accordance with Rule 64 of the Federal Rules of Civil Procedure and this Court's inherent equitable powers to issue remedies ancillary to its authority to provide final relief, and given the difficulties Plaintiff would have enforcing this Default Judgment Order, the Court also hereby grants Plaintiff's request for a post-judgment restraining order continuing the attachment of each Defaulting Defendant's Frozen Assets until Plaintiff has recovered the full payment of Defaulting Defendants' Individual Damages Award owed to it by that Defaulting Defendant under this Default Judgment Order, or until further order of this Court; and
- 3) IT IS FURTHER ORDERED, ADJUDGED AND DECREED that in accordance with this Court's inherent equitable powers to issue remedies ancillary to its authority to provide final relief, and given the difficulties Plaintiff would have enforcing this Default Judgment Order, until Plaintiff has recovered the full payment of Defaulting Defendants' Individual Damages Award owed to it by any Defaulting Defendant under this Default Judgment Order, in the event

that Plaintiff discovers new and/or additional Defaulting Defendants' Assets (whether said assets are located in the U.S. or abroad) and/or Defaulting Defendants' Financial Accounts (whether said account is located in the U.S. or abroad) ("Defaulting Defendants' Additional Assets" and "Defaulting Defendants' Additional Financial Accounts," respectively), Plaintiff shall have the ongoing authority to serve this Default Judgment Order on any Financial Institutions controlling or otherwise holding such Defaulting Defendants' Additional Assets and/or Defaulting Defendants' Additional Financial Accounts ("Financial Institutions Holding Defaulting Defendants' Additional Assets and/or Financial Accounts");

- A. Upon notice of this Default Judgment Order, Financial Institutions Holding Defaulting Defendants' Additional Assets and/or Financial Accounts shall immediately locate Defaulting Defendants' Additional Financial Accounts, attach and restrain such Defaulting Defendants' Additional Assets in Defaulting Defendants' Additional Financial Accounts from being secreted, concealed, transferred or disposed of or withdrawn; and
- B. After twenty (20) business days following the service of this Default Judgment Order on Financial Institutions Holding Defaulting Defendants' Additional Assets and/or Financial Accounts, Financial Institutions Holding Defaulting Defendants' Additional Assets and/or Financial Accounts shall transfer all of Defaulting Defendants' Additional Assets to Plaintiff as partial or full satisfaction of Defaulting Defendants' Individual Damages Award, unless Defaulting Defendant has filed with this Court and served upon Plaintiff's counsel a request that such Defaulting Defendants' Additional Assets be exempted from this Default Judgment Order.

V. Miscellaneous Relief

- 1) Defaulting Defendants may, upon proper showing and two (2) business days written notice to the Court and Plaintiff's counsel, appear and move for dissolution or modification of the provisions of this Default Judgment Order concerning the restriction or restraint of Defaulting Defendants' Frozen Assets, Defaulting Defendants' Additional Assets and/or Defaulting Defendants' Additional Financial Accounts;
- 2) Any failure by Defaulting Defendants to comply with the terms of this Default Judgment Order shall be deemed contempt of Court, subjecting Defaulting Defendants to contempt remedies to be determined by the Court, including fines and seizure of property; and
- 3) This Court shall retain jurisdiction over this matter and the parties in order to construe and enforce this Default Judgment Order.

SO ORDERED.

SIGNED this 17<sup>th</sup> day of December, 2018, at 1:00 p.m.

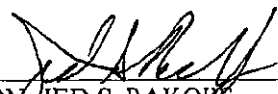
  
\_\_\_\_\_  
HON. JED S. RAKOFF  
UNITED STATES DISTRICT JUDGE



USDC SDNY  
DOCUMENT  
ELECTRONICALLY FILED  
DOC #:  
DATE FILED: 11/26/2018

Jason M. Drangel (JD 7204)  
[jdrangel@ipcounselors.com](mailto:jdrangel@ipcounselors.com)  
Ashly E. Sands (AS 7715)  
[asands@ipcounselors.com](mailto:asands@ipcounselors.com)  
Spencer J. Wolfgang (SW 2389)  
[swolgang@ipcounselors.com](mailto:swolgang@ipcounselors.com)  
Mary Kate Brennan (MB 5595)  
[mbrennan@ipcounselors.com](mailto:mbrennan@ipcounselors.com)  
Brieanne Scully (BS 3711)  
[bscully@ipcounselors.com](mailto:bscully@ipcounselors.com)  
EPSTEIN DRANGEL LLP  
60 East 42<sup>nd</sup> Street, Suite 2520  
New York, NY 10165  
Telephone: (212) 292-5390  
Facsimile: (212) 292-5391  
*Attorneys for Plaintiffs*  
*Moose Toys Pty LTD; Moose Creative Pty LTD;*  
*Moose Enterprise Pty LTD;*  
*and Moose Creative Management Pty LTD*

UNITED STATES DISTRICT COURT  
SOUTHERN DISTRICT OF NEW YORK

MOOSE TOYS PTY LTD, MOOSE CREATIVE PTY LTD, MOOSE ENTERPRISE PTY LTD, and MOOSE CREATIVE MANAGEMENT PTY LTD,  
*Plaintiffs*

v.

963, 369EXPRESS, AISHINE, ALIPAPA COMPANY, AREKE.CO.,LTD SHOP ONLINE, ARRIVAL, BAIYUN CO.,LTD, BALSMPFHEE7, BEIRE CLOTHING CO., LTD (158), BENJAMI, BESTBUY-FASTSHIP, BETTERLIFE2014, BLACKSOUL, BLISS, BRENDABEAR, CAITAI LED APPLICATION, CHANFEN, CHERRY LARRY, CHONGQING, HONGTAI TRADE CO., LTD., CLOTHES STEWARD EUROPEAN STATION AUTHENTIC, COCO132, COFFEENETWORK, COHAT, COOL-XMAN, DMT, DONG@WEI, EARTH GLOBAL SALE, EXPERTS GATHERED SHOP, FANTASY INTERNATIONAL, FASHION HUNTER, FASHION KINGDOM2, FASHION NEW, FASHION RAINBOW, FASHIONSTORETOP, FASTESTEVER, FDSFDEW, FENG YU GE, FLYING OWL, FOR YOU

**CIVIL ACTION No.  
18-cv-2187 (VEC)**

**~~PROPOSED~~ FINAL  
DEFAULT JUDGMENT AND  
PERMANENT INJUNCTION  
ORDER**

TO, FOREVERFIVE, FORMER98, GINOPLUS,  
GROCERY STORES, HAPPYSHOPPINGOGO,  
HARRY'S TOYS, HELLO MIYA, HELLOW SHOP,  
HEPING12, HIMALAYAMALL1, HITOM,  
HONEYKIMI, HONG\_56, HUANGMALL,  
HUHONGYU759, IN JULY THE STARRY SKY,  
JIANGXINANCHANG527, JINGJING88,  
JINGNANSHANMAO, JINGZHOU CITY SANSHI  
TUWEN ADVERTISING CO., LTD, JINGZHOU  
JIAHANG TEXTILE CO., LTD, KA-AVALON,  
KANGXI, KATHARINE ELIZABETH, KEHUI  
ELECTRICAL CO., LTD., KK-MALL SHOP ONLINE,  
LANCER.CC, LAOPWU, LEBANG, LIBING183,  
LIHONGYIDINGHONG, LINJIANFENGSHOP,  
LINMENG, LITTLE BIG SHOP, LIUYUANLLYY,  
LOURDES GOMEZ, LOVELIFELOVEYOU, LZXH,  
MAIJJI, MAOGUANGJU, MARK\_DOOLE, MOLDE  
CANTICLE, MOLLYWYH@126.COM, MOLY  
STORE, MXMDD, NANJING DAYSTAR  
INTERNATIONAL, NITAISHENLE, NJ 3C, ONE2,  
ONEEYEDBLUEDOG, OPTIMUMFULFILLMENT,  
ORANGE666, PINKLADYMALL, PRUDENTIAL  
SOURCE DIGITAL FRANCHISE STORE,  
PURE\*CHINA, QUICK, RAY STORE, RORED,  
RUOZHIRUCHUJIAN, SATBN&166, SEVEN TING  
SHOP, SHANGHAIYIXINFUSHIYOUXIANGONGSI,  
SHARENICE, SHENZHEN YIGOU COMPANY,  
SMALL COMMODITY OCEAN, SPANCIL HILL,  
STRONGCHEN34, TAOTAOJIANGSHUI, THE  
INTERNATIONAL TIDE SHOES STORE , TIANING,  
TIMIA, TINGYUDAHE, TOY108, TRENDSTYLE06,  
WEIMAOYI, WINDBELLER, WOHENMEILI,  
WOSHIHAOREN, WUHAN INTEGRITY TRADING  
CO., LTD, WUHAN KE MEIYA, WUHAN XIN  
CHENG EXCELLENT PRODUCTS, WXY666,  
XIANGQIU, XIEMENASD, XINGRUI MUYING  
YONGPIIN CO., LTD, XINHUALTD, XPO, XYC147,  
YEONLY YOU, YINSHUSTORES,  
YIWUYUNDONGHUWAISHANGMAOGONGSI,  
YOUNG AGE, YOUNG STUDIO and ZHAOLING55,  
*Defendants*

This matter comes before the Court upon Motion by Plaintiff Moose Toys Pty LTD, Plaintiff Moose Creative Pty LTD, Plaintiff Moose Enterprise Pty LTD and Moose Creative Management Pty LTD (collectively, “Moose” or “Plaintiffs”) for the entry of a final judgment and permanent injunction by default as to Defendant 369express (“Defaulting Defendant”) for Defaulting Defendant’s trademark infringement, trademark counterfeiting, false designation of origin, passing off, unfair competition, copyright infringement and related state and common law claims arising out of Defaulting Defendant’s unauthorized use of Plaintiffs’ Shopkins Marks and Shopkins Works, without limitation, in its manufacturing, importing, exporting, advertising, marketing, promoting, distributing, displaying offering for sale and/or selling offering for sale and/or sale of Counterfeit Products.<sup>1</sup>

The Court, having considered the Affidavit of Spencer Wolfgang in support of Plaintiffs’ Motion for Default Judgment and a Permanent Injunction (“Motion for Default Judgment”), the Certificate of Service of the Summons and Complaint, the Certificate of the Clerk of the Court and upon all other pleadings and papers on file in this Action, it is hereby ORDERED, ADJUDGED AND DECREED as follows (hereinafter, “Default Judgment Order”):

**I. Defaulting Defendant’s Liability**

- 1) Judgment is granted in favor of Plaintiffs on all claims asserted against Defaulting Defendant in the Complaint;

**II. Damages Awards**

- 1) IT IS FURTHER ORDERED, ADJUDGED AND DECREED that because it would serve both the compensatory and punitive purposes of the Lanham Act’s prohibitions on willful

---

<sup>1</sup> Where a defined term is referenced herein and not defined herein, the defined term should be understood as it is defined in the Complaint or Application.

infringement, and because Plaintiffs have sufficiently set forth the basis for the statutory damages awards requested in their Motion for Default Judgment, the Court finds such an award to be reasonable and Plaintiffs awarded seven hundred and fifty thousand dollars (\$750,000.00) (“Defaulting Defendant’s Individual Damages Award”) in statutory damages against Defaulting Defendant pursuant to Section 15 U.S.C. § 1117(c) of the Lanham Act as follows, plus post-judgment interest;

### **III. Permanent Injunction**

- 1) IT IS FURTHER ORDERED, ADJUDGED AND DECREED that Defaulting Defendant, its respective officers, agents, servants, employees, successors and assigns and all persons acting in concert with or under the direction of Defaulting Defendant (regardless of whether located in the United States or abroad), who receive actual notice of this Order, including, without limitation, any: (1) banks, financial institutions, credit card companies and payment processing agencies, such as ContextLogic, PayPal Inc. (“PayPal”), Payoneer Inc. (“Payoneer”), the Alibaba Group d/b/a Alibaba.com and AliExpress.com (“Alibaba”) payment services (*e.g.*, Alipay.com Co., Ltd., Ant Financial Services Group), PingPong Global Solutions, Inc. (“PingPong”) and other companies or agencies that engage in the processing or transfer of money and/or real or personal property of Defaulting Defendant (“Financial Institutions”) and (2) Wish.com, a global online marketplace and eCommerce platform, which is owned by ContextLogic, Inc., a Delaware corporation (“ContextLogic”), that allows manufacturers, wholesalers and third-party merchants to advertise, distribute, offer for sale, sell and ship retail products originating from, primarily, China, amongst other locations, directly to consumers worldwide and specifically to consumers residing in the U.S., including New York (“Wish”), as well as those platforms and/or entities identified as a result of any expedited discovery order

entered in the Lawsuit (hereinafter collectively referred to as the “Restrained Persons”), are permanently enjoined and restrained from:

- A. manufacturing, importing, exporting, advertising, marketing, promoting, distributing, displaying, offering for sale, selling and/or otherwise dealing in Counterfeit Products and/or Infringing Products or any other products bearing the Shopkins Marks and/or marks that are confusingly similar to, identical to and constitute a counterfeiting and/or infringement of the Shopkins Marks and/or incorporating the Shopkins Works and/or artwork that is substantially similar to, identical to and constitute infringement of the Shopkins Works;
- B. directly or indirectly infringing in any manner any of Plaintiffs’ trademarks, copyrights or other rights (whether now in existence or hereafter created) including, without limitation, the Shopkins Marks or Shopkins Works;
- C. using any reproduction, counterfeit, copy or colorable imitation of Plaintiffs’ trademarks, copyrights or other rights (whether now in existence or hereafter created) including, without limitation, the Shopkins Marks and Shopkins Works to identify any goods or services not authorized by Plaintiffs;
- D. using any of Plaintiffs’ trademarks, copyrights or other rights (whether now in existence or hereafter created) including, without limitation, the Shopkins Marks and Shopkins Works, or any other marks or artwork that are confusingly or substantially similar to the Shopkins Marks and Shopkins Works on or in connection with Defaulting Defendant’s manufacturing, importing, exporting, advertising, marketing, promoting, distributing, displaying, offering for sale, selling and/or otherwise dealing in the Counterfeit Products and/or Infringing Products;

- E. using any false designation of origin or false description, or engaging in any action which is likely to cause confusion, cause mistake and/or to deceive members of the trade and/or the public as to the affiliation, connection or association of any product manufactured, imported, exported, advertised, marketed, promoted, distributed, displayed, offered for sale or sold by Defaulting Defendant with Plaintiffs, and/or as to the origin, sponsorship or approval of any product manufactured, imported, exported, advertised, marketed, promoted, distributed, displayed, offered for sale or sold by Defaulting Defendant and Defaulting Defendant's commercial activities by Plaintiffs;
- F. secreting, concealing, destroying, altering, selling off, transferring or otherwise disposing of and/or dealing with: (i) Counterfeit Products; (ii) any computer files, data, business records, documents or any other records or evidence relating to:
- i. any and all websites and/or accounts held by or associated with Defaulting Defendant, its respective officers, employees, agents, servants and all persons in active concert or participation with any of them ("User Accounts") and/or Defaulting Defendant's User Accounts through which Defaulting Defendant, its respective officers, employees, agents, servants and all persons in active concert or participation with any of them manufacture, import, export, advertise, market, promote, distribute, offer for sale, sell and/or otherwise deal in products, including the Counterfeit Products, which are held by or associated with Defaulting Defendant, its respective officers, employees, agents, servants and all persons in active concert or participation with any of them ("Merchant Storefront(s)");

- j. Defaulting Defendant's Assets (as defined *infra*), and
  - k. the manufacture, importation, exportation, advertising, marketing, promotion, distribution, display, offering for sale and/or sale of Counterfeit Products by Defaulting Defendant and by its respective officers, employees, agents, servants and all persons in active concert or participation with any of them;
- G. secreting, concealing, transferring, disposing of, withdrawing, encumbering or paying any money, securities or other property or assets of Defaulting Defendant (whether said assets are located in the U.S. or abroad) ("Defaulting Defendant's Assets") from or to accounts associated with or utilized by Defaulting Defendant or any of Defaulting Defendant's User Accounts or Merchant Storefronts (whether said account is located in the U.S. or abroad) ("Defaulting Defendant's Financial Accounts") until further ordered by this Court;
- H. effecting assignments or transfers, forming new entities or associations, or creating and/or utilizing any other platform, User Accounts, Merchant Storefronts or any other means of importation, exportation, advertising, marketing, promotion, distribution, display, offering for sale and/or sale of Counterfeit Products for the purposes of circumventing or otherwise avoiding the prohibitions set forth in this Default Judgment Order;
- I. providing services to Defaulting Defendant and Defaulting Defendant's User Accounts and Merchant Storefronts, including, without limitation, continued operation of Defaulting Defendant's User Accounts and Merchant Storefronts; and

J. knowingly instructing, aiding or abetting any other person or business entity in engaging in any of the activities referred to in subparagraphs (II)(1)(A) through (I) *supra*.

2) IT IS FURTHER ORDERED, ADJUDGED AND DECREED that Defaulting Defendant must deliver up for destruction to Plaintiffs any and all Counterfeit Products and any and all packaging, labels, tags, advertising and promotional materials and any other materials in the possession, custody or control of Defaulting Defendant that infringe any of Plaintiffs' trademarks, copyrights or other rights including, without limitation, the Shopkins Marks or Shopkins Works, or bear any marks that are confusingly or substantially similar to the Shopkins Marks and Shopkins Works pursuant to 15 U.S.C. § 1118;

#### **IV. Post-Judgment Asset Transfer and Asset Freeze Order**

1) IT IS FURTHER ORDERED, ADJUDGED AND DECREED that in accordance with Rule 64 of the Federal Rules of Civil Procedure, 15 U.S.C. § 1116(a) and this Court's inherent equitable powers to issue remedies ancillary to its authority to provide final relief, and given the difficulties Plaintiffs would have enforcing this Default Judgment Order, Defaulting Defendant's Assets from Defaulting Defendant's Financial Accounts that were and/or are attached and frozen or restrained pursuant to the TRO and/or PI Order, or which are attached and frozen or restrained pursuant to any future order entered by the Court in this Action, (collectively, "Defaulting Defendant's Frozen Assets" and "Defaulting Defendant's Frozen Accounts," respectively), are, to the extent that Defaulting Defendant's Frozen Assets equal Defaulting Defendant's Individual Damages Award, hereby released and transferred to Plaintiffs as full satisfaction of Defaulting Defendant's Individual Damages Award, and those Defaulting Defendant's Frozen Assets shall be transferred to Plaintiffs through Plaintiffs'

counsel forthwith, and upon receipt by Plaintiffs' counsel of Defaulting Defendant's Frozen Assets in full satisfaction of Defaulting Defendant's Individual Damages Award, the Financial Institution(s) holding Defaulting Defendant's Frozen Assets and Defaulting Defendant's Frozen Accounts may unfreeze that Defaulting Defendant's Frozen Assets and Defaulting Defendant's Frozen Accounts. To the extent that Defaulting Defendant's Frozen Assets are less than Defaulting Defendant's Individual Damages Award, Defaulting Defendant's Frozen Assets are hereby released and transferred to Plaintiffs as partial satisfaction of Defaulting Defendant's Individual Damages Award for Defaulting Defendant and Defaulting Defendant's Frozen Assets shall be transferred to Plaintiffs through Plaintiffs' counsel forthwith, and

- 2) IT IS FURTHER ORDERED, ADJUDGED AND DECREED that in accordance with Rule 64 of the Federal Rules of Civil Procedure and this Court's inherent equitable powers to issue remedies ancillary to its authority to provide final relief, and given the difficulties Plaintiffs would have enforcing this Default Judgment Order, the Court also hereby grants Plaintiffs' request for a post-judgment restraining order continuing the attachment of Defaulting Defendant's Frozen Assets until Plaintiffs have recovered the full payment of Defaulting Defendant's Individual Damages Award owed to them by Defaulting Defendant under this Default Judgment Order, or until further order of this Court; and
- 3) IT IS FURTHER ORDERED, ADJUDGED AND DECREED that in accordance with this Court's inherent equitable powers to issue remedies ancillary to its authority to provide final relief, and given the difficulties Plaintiffs would have enforcing this Default Judgment Order, until Plaintiffs have recovered the full payment of Defaulting Defendant's Individual Damages Award owed to them by Defaulting Defendant under this Default Judgment Order, in the event that Plaintiffs discover new and/or additional Defaulting Defendant's Assets (whether said

assets are located in the U.S. or abroad) and/or Defaulting Defendant's Financial Accounts (whether said account is located in the U.S. or abroad) ("Defaulting Defendant's Additional Assets" and "Defaulting Defendant's Additional Financial Accounts," respectively), Plaintiffs shall have the ongoing authority to serve this Default Judgment Order on any Financial Institutions controlling or otherwise holding such Defaulting Defendant's Additional Assets and/or Defaulting Defendant's Additional Financial Accounts ("Financial Institutions Holding Defaulting Defendant's Additional Assets and/or Financial Accounts");

- A. Upon notice of this Default Judgment Order, Financial Institutions Holding Defaulting Defendant's Additional Assets and/or Financial Accounts shall immediately locate Defaulting Defendant's Additional Financial Accounts, attach and restrain such Defaulting Defendant's Additional Assets in Defaulting Defendant's Additional Financial Accounts from being secreted, concealed, transferred or disposed of or withdrawn; and
- B. After twenty (20) business days following the service of this Default Judgment Order on Financial Institutions Holding Defaulting Defendant's Additional Assets and/or Financial Accounts, Financial Institutions Holding Defaulting Defendant's Additional Assets and/or Financial Accounts shall transfer all Defaulting Defendant's Additional Assets to Plaintiffs as partial or full satisfaction of Defaulting Defendant's Individual Damages Award, unless Defaulting Defendant has filed with this Court and served upon Plaintiffs' counsel a request that such Defaulting Defendant's Additional Assets be exempted from this Default Judgment Order.

**V. Miscellaneous Relief**

- 1) Defaulting Defendant may, upon proper showing and two (2) business days written notice to the Court and Plaintiffs' counsel, appear and move for dissolution or modification of the provisions of this Default Judgment Order concerning the restriction or restraint of Defaulting Defendant's Frozen Assets, Defaulting Defendant's Additional Assets and/or Defaulting Defendant's Additional Financial Accounts;
- 2) Any failure by Defaulting Defendant to comply with the terms of this Default Judgment Order shall be deemed contempt of Court, subjecting Defaulting Defendant to contempt remedies to be determined by the Court, including fines and seizure of property; and
- 3) This Court shall retain jurisdiction over this matter and the parties in order to construe and enforce this Default Judgment Order.

**SO ORDERED.**

SIGNED this 26 day of November, 2018, at 5:00 p.m. .m.  
New York, New York

  
\_\_\_\_\_  
HON. VALERIE E. CAPRONI  
UNITED STATES DISTRICT JUDGE



USDC SDNY  
DOCUMENT  
ELECTRONICALLY FILED  
DOC #:  
DATE FILED: 11/16/2018

Jason M. Drangel (JD 7204)  
[jdrangel@ipcounselors.com](mailto:jdrangel@ipcounselors.com)  
Ashly E. Sands (AS 7715)  
[asands@ipcounselors.com](mailto:asands@ipcounselors.com)  
William C. Wright (WW 2213)  
[bwright@ipcounselors.com](mailto:bwright@ipcounselors.com)  
Spencer Wolfgang (SW 2389)  
[swolfgang@ipcounselors.com](mailto:swolfgang@ipcounselors.com)  
Mary Kate Brennan (MB 5595)  
[mbrennan@ipcounselors.com](mailto:mbrennan@ipcounselors.com)  
Brieanne Scully (BS 3711)  
[bscully@ipcounselors.com](mailto:bscully@ipcounselors.com)  
EPSTEIN DRANGEL LLP  
60 East 42<sup>nd</sup> Street, Suite 2520  
New York, NY 10165  
Telephone: (212) 292-5390  
Facsimile: (212) 292-5391

Brian Igel (BI 4574)  
[bigel@bilawfirm.com](mailto:bigel@bilawfirm.com)  
BELLIZIO + IGEL  
One Grand Central Place  
305 Madison Avenue, 40<sup>th</sup> Floor  
New York, New York 10165  
Telephone: (212) 873-0250  
Facsimile: (646) 395-1585  
*Attorneys for Plaintiff*  
*Off-White LLC*

UNITED STATES DISTRICT COURT  
SOUTHERN DISTRICT OF NEW YORK

OFF-WHITE LLC,

*Plaintiff*

v.

A445995685, ANKOU, ARIESEE,  
BAINAOHUI621@163.COM, BAOWENBEI, BEAUTIFUL  
AREA, BEIBEIKEJIYOUXIANGONGSI, BILLY CRYSTAL  
SHOP, BIN-Z, BLUEREDFASHION, BONNIE\_HE,  
BRILLIANCE CO., LTD., BUDGET STORE, CACO, CAOZHI,  
CAVS, CHACHASHOP2, CHENG'S BROTHER, CSHUI,  
DJMRZHANG, DREAM-XIE, DUANFANFAN,

CIVIL ACTION No.  
18-cv-2099 (LGS)

**[AMENDED  
PROPOSED]  
FINAL DEFAULT  
JUDGMENT AND  
PERMANENT  
INJUNCTION  
ORDER**

DUODUOSHoes, DUYINGFEN, EASY BUY\_69, EDIT, FASHION HOUSE CO., LTD., FASHION1900, FATEGRANDNESS, FEIFANMAOYI, FEIHONG TECHNOLOGY CO., LTD, FELLINGPU, FLASH TOP, FLORENCEFASHION, FUJIAN XINCHENG CORPORATION, FUJIANANXICOLTD, FUXIAOSEN, GAGALADY\_LI, GAGAR, GAME DEVIL, GAO GAO SHOPPING, GAOFEN8730, GAZEBO, GOGOGOSHOPIT, GOWNS, GRACE\_K, GREAT WELL-OFF TRADE CO, LTD, HAPPYTIMEYA, HEIDAO, HELLO1, HENENG, HEXIAOLI, HIGH LANDS, HOOK, HOTOP, HUANGLIANGFENG, HUKIO INTERNATIONAL, HUQIU AISHANG WEDDING DRESSES & EVENING DRESSES STORE, I DRESS MY PANTS, IT'S UNBELIEVABLE, JHEER, JOYWEDDING2016, JUMN, KELVIN'S DREAM, KIKIT, KINDLY SMILE, KUNGE CO,LTD, LAST ORDER, LASTED, LCON, LI LI LOVE SHOP, LIANXIN, LIJUN\_WU, LINGFASHION, LISA'S CROCHET, LIUGANGHUI, LOVE OF GOD, LOVE OF LOVER, LOVELH, LUCKY CHAMPION, LUCKY PAN, LUINGTING, LUQILIN5922, LXPWUQ, M.KILING, MAN'S WORLD, MARVELLOUS WORLD, MEANS ZORE, MEETGT, MEILIIJIA, MING\_CLOTHING, MIYAVI, MORDERN LIFE INTERNATIONAL, MOSKUSHAMN, NEW SKY NEW LIFE, OFF WHITE NEW SHOP, OHEIYOUFASHION, ONSALESTORE886, PANGXIANSENCHAO PAIDAMANANZHUANGDIAN, PEACEFUL LIFE, PERSONALIZED CLOTHING, POLY FAMOUS TRADING CO LTD, PROFESSIONAL, QIUMIN\_FASHION, QIUXIULING, QIXIAORAN28, QQ\_200815@163.COM, QUARTERBACK, RUILY, SANMATIN, SERENA ANGELCITY, SHENJINQI, SHENZHENOUAILICOLTD, SHISHANGPINPAI, SHOP8, SHOPPER'S PARADISE, SIX DAYS, SPRING WIND, SRUER COSTUME, SU\_FASHION, SUMAIL BUSINESS GROU, SUMMER TIME GONE, SUNNY SEE, SUNXIAOULI, SWEET-WIND, THE MEN'S WORLD, THE OLN, TIMOTHY5566, TOP-ANNY, TRAVELERS, TRENDY\_WORLD, VINTAGE COLLECTIONS, WANG STORE ONE, WEBBER123, WEYMOUTH, WHITE OFF SHOP, WONDERLIST, WUHANXINGDAHENGJIASHANGMAOYOUXIANGONGSI, WY STORE, XIAODIANPUYOUNI, XPRESS SHARE, XSHIN, XUNLONGS, YA TOU HE, YABAR, YAOJUNMAOMALL, YEONLY YOU, YIJIANHUI, YIWU E-COMMERCE LIMITED, YUHUIYU654, YUNYUNSHOP, YUSANX, YUXIAOLI, ZBY0913, ZERO ZONE, ZHAOJIQUAN,

ZHEJIANGAIZESIMAOYIYOUXIANGONGSI,  
ZHIMATANG, ZHOUJIEYUE0909, ZHUANSHUZHUYI, AND  
ZUOZUIMEIZIJI,

*Defendants*

This matter comes before the Court upon Motion by Plaintiff Off-White LLC (“Off-White” or “Plaintiff”) for the entry of a final judgment and permanent injunction by default against the following Defendants: A445995685, ANKOU, ARIESEE, BAINAOHUI621@163.COM, BEIBEIKEJIYOUXIANGONGSI, BILLY CRYSTAL SHOP, BIN-Z, BLUEREDFASHION, BRILLIANCE CO., LTD., BUDGET STORE, CAOZHI, CAVS, CHENG'S BROTHER, DJMRZHANG, DREAM-XIE, DUANFANFAN, DUODUOSHoes, DUying FEN, EASY BUY\_69, FASHION HOUSE CO., LTD., FASHION1900, FATEGRANDNESS, FEIHONG TECHNOLOGY CO., LTD, FELLINGPU, FLASH TOP, FLORENCEFASHION, FUJIANANXICOLTD, FUXIAOSEN, GAGALADY\_LI, GAME DEVIL, GAO GAO SHOPPING, GAOFEN8730, GRACE\_K, GREAT WELL-OFF TRADE CO, LTD, HAPPYTIMEYA, HEXIAOLI, HIGH LANDS, HOOK, HUANGLIANGFENG, HUKIO INTERNATIONAL, HUQIU AISHANG WEDDING DRESSES & EVENING DRESSES STORE, I DRESS MY PANTS, IT'S UNBELIEVABLE, JHEER, JOYWEDDING2016, KINDLY SMILE, KUNGE CO, LTD, LAST ORDER, LI LI LOVE SHOP, LIJUN\_WU, LISA'S CROCHET, LIUGANG HUI, LOVE OF GOD, LOVE OF LOVER, LOVELH, LUCKY CHAMPION, LUCKY PAN, MAN'S WORLD, MARVELLOUS WORLD, MEANS ZORE, MEETGT, MIYAVI, MORDERN LIFE INTERNATIONAL, MOSKUSHAMN, NEW SKY NEW LIFE, OFF WHITE NEW SHOP, OHEIYOUFASHION, ONSALESTORE886, PANGXIANSENCHAO PAIDAMANANZ HUANGDIAN, PEACEFUL LIFE,

PERSONALIZED CLOTHING, POLY FAMOUS TRADING CO LTD, PROFESSIONAL, QIUMIN\_FASHION, RUILY, SANMATIN, SERENA ANGELCITY, SHENZHENOUAILICOLT, SHOP8, SIX DAYS, SU\_FASHION, SUMAIL BUSINESS GROUP, SUNXIAO ULI, THE MEN'S WORLD, THE OLN, TIMOTHY5566, TOP-ANNY, TRAVELERS, WANG STORE ONE, WEBBER123, WEYMOUTH, WHITE OFF SHOP, WONDERLIST, WUHANXINGDAHENGJIASHANGMAOYOUXIANGONGSI, WY STORE, XSHIN, YA TOU HE, YAOJUNMAO MALL, YEONLY YOU, YIJIANHUI, YIWU E-COMMERCE LIMITED, YUHUIYU654, ZBY0913, ZERO ZONE, ZHAOJIQUAN, ZHOUIEYUE0909, ZHUANS HUZHIYI and ZUOZUIMEIZIJI (collectively hereinafter referred to as "Defaulting Defendants") for Defaulting Defendants' trademark infringement, trademark counterfeiting, false designation of origin, passing off, unfair competition and related state and common law claims arising out of Defaulting Defendants' unauthorized use of Plaintiff's Off-White Marks, without limitation, in their manufacturing, importing, exporting, advertising, marketing, promoting, distributing, displaying offering for sale and/or selling offering for sale and/or sale of Counterfeit Products.<sup>1</sup>

The Court, having considered the Affidavit of Spencer Wolfgang in support of Plaintiff's Motion for Default Judgment and a Permanent Injunction ("Motion for Default Judgment"), the Certificate of Service of the Summons and Complaint, the Certificate of the Clerk of the Court and upon all other pleadings and papers on file in this Action, it is hereby ORDERED, ADJUDGED AND DECREED as follows (hereinafter, "Default Judgment Order"):

---

<sup>1</sup> Where a defined term is referenced herein and not defined herein, the defined term should be understood as it is defined in the Complaint or Application.

**I. Defaulting Defendants' Liability**

1) Judgment is granted in favor of Plaintiff on all claims asserted against Defaulting Defendants in the Complaint;

**II. Damages Awards**

1) IT IS FURTHER ORDERED, ADJUDGED AND DECREED that because it would serve both the compensatory and punitive purposes of the Lanham Act's prohibitions on willful infringement, and because Plaintiff has sufficiently set forth the basis for the statutory damages awards requested in its Motion for Default Judgment, the Court finds that such awards are reasonable and Plaintiff is awarded statutory damages against each of the Defaulting Defendants pursuant to Section 15 U.S.C. § 1117(c) of the Lanham Act as follows, plus post-judgment interest:

<b>DEFAULTING DEFENDANT</b>	<b>REQUESTED STATUTORY DAMAGES</b>
BLUEREDFASHION	\$100,000.00
DUYING FEN	\$100,000.00
FUXIAOSEN	\$100,000.00
GAO GAO SHOPPING	\$100,000.00
HAPPYTIMEYA	\$100,000.00
IDRESS MY PANTS	\$100,000.00
IT'S UNBELIEVABLE	\$100,000.00
LIJUN_WU	\$100,000.00
LISA'S CROCHET	\$100,000.00

LUCKY PAN	\$100,000.00
MAN'S WORLD	\$100,000.00
OHEIYOUFASHION	\$100,000.00
ONSALESTORE886	\$100,000.00
SHENZHENOUAILICOLTD	\$100,000.00
SIX DAYS	\$100,000.00
SUNXIAOULI	\$100,000.00
WONDERLIST	\$100,000.00
WUHANXINGDAHENGJIASHANGMAOYOUXIANGONGSI	\$100,000.00
YAOJUNMAO MALL	\$100,000.00
ZHAOJIQUAN	\$100,000.00
EASY BUY_69	\$100,000.00
FATEGRANDNESS	\$100,000.00
GREAT WELL-OFF TRADE CO, LTD	\$100,000.00
HIGH LANDS	\$100,000.00
JHEER	\$100,000.00
PEACEFUL LIFE	\$100,000.00
RUILY	\$100,000.00
TIMOTHY5566	\$100,000.00
YUHUIYU654	\$100,000.00
DUODUOSHoes	\$100,000.00

FUJIANANXICOLT	\$100,000.00
HUKIO INTERNATIONAL	\$100,000.00
SHOPS	\$100,000.00
MIYAVI	\$100,000.00
GRACE_K	\$100,000.00
ZHO UJIEYUE0909	\$100,000.00
FLASH TOP	\$100,000.00
FLORENCEFASHION	\$100,000.00
SERENA ANGELCITY	\$100,000.00
GAOFEN8730	\$100,000.00
BEIBEIKEJIYOUXIANGONGSI	\$100,000.00
YEONLY YOU	\$100,000.00
SUMAIL BUSINESS GROUP	\$100,000.00
ZBY0913	\$100,000.00
NEW SKY NEW LIFE	\$100,000.00
POLY FAMOUS TRADING CO LTD	\$100,000.00
FASHION1900	\$100,000.00
GAME DEVIL	\$100,000.00
LUCKY CHAMPION	\$100,000.00
JOYWEDDING2016	\$100,000.00
YA TOU HE	\$100,000.00

LIUGANG HUI	\$100,000.00
DUANFANFAN	\$100,000.00
LILI LOVE SHOP	\$100,000.00
PERSONALIZED CLOTHING	\$100,000.00
BILLY CRYSTAL SHOP	\$100,000.00
HOOK	\$100,000.00
MEANS ZORE	\$100,000.00
HUANGLIANGFENG	\$100,000.00
OFF WHITE NEW SHOP	\$100,000.00
WEBBER123	\$100,000.00
WHITE OFF SHOP	\$200,000.00
PROFESSIONAL	\$200,000.00
DJMRZHANG	\$200,000.00
LOVE OF GOD	\$200,000.00
MEETGT	\$200,000.00
A445995685	\$200,000.00
KINDLY SMILE	\$200,000.00
QIUMIN_FASHION	\$200,000.00
KUNGE CO, LTD	\$200,000.00
WEYMOUTH	\$200,000.00
YIJIANHUI	\$200,000.00

CAOZHI	\$200,000.00
CAVS	\$200,000.00
HEXIAOLI	\$200,000.00
ANKOU	\$200,000.00
TRAVELERS	\$200,000.00
BAINAOHUI621@163.COM	\$200,000.00
LAST ORDER	\$300,000.00
FELLINGPU	\$300,000.00
MODERN LIFE INTERNATIONAL	\$300,000.00
XSHIN	\$300,000.00
BUDGET STORE	\$300,000.00
YIWU E-COMMERCE LIMITED	\$300,000.00
PANGXIANSENCHAO PAIDAMANANZHUANGDIAN	\$300,000.00
BRILLIANCE CO., LTD.	\$300,000.00
WANG STORE ONE	\$400,000.00
ARIESEE	\$400,000.00
LOVE OF LOVER	\$400,000.00
TOP-ANNY	\$400,000.00
LOVELH	\$400,000.00
SU_FASHION	\$500,000.00
FASHION HOUSE CO., LTD.	\$750,000.00

DREAM-XIE	\$750,000.00
HUQIU AISHANG WEDDING DRESSES & EVENING DRESSES STORE	\$750,000.00
CHENG'S BROTHER	\$1,000,000.00
ZHUANS HUZHIYI	\$1,500,000.00
THE MEN'S WORLD	\$1,500,000.00
THE OLN Y	\$2,000,000.00
FEIHONG TECHNOLOGY CO., LTD.	\$2,000,000.00
BIN-Z	\$2,000,000.00
MARVELLOUS WORLD	\$2,000,000.00
GAGALADY_LI	\$2,000,000.00
WY STORE	\$2,000,000.00
SANMATIN	\$2,000,000.00
ZUOZUI MEIZIJI	\$2,000,000.00
MOSKUSHAMN	\$2,000,000.00
ZERO ZONE	\$2,000,000.00

**III. Permanent Injunction**

1) IT IS FURTHER ORDERED, ADJUDGED AND DECREED that Defaulting Defendants, their respective officers, agents, servants, employees, successors and assigns and all persons acting in concert with or under the direction of Defaulting Defendants (regardless of whether located in the United States or abroad), who receive actual notice of this Order, including, without limitation, any: (1) banks, financial institutions, credit card companies and payment

processing agencies, such as ContextLogic, PayPal Inc. (“PayPal”), Payoneer Inc. (“Payoneer”), the Alibaba Group d/b/a Alibaba.com and AliExpress.com (“Alibaba”) payment services (e.g., Alipay.com Co., Ltd., Ant Financial Services Group), PingPong Global Solutions, Inc. (“PingPong”) and other companies or agencies that engage in the processing or transfer of money and/or real or personal property of Defaulting Defendant (“Financial Institutions”) and (2) Wish.com, a global online marketplace and eCommerce platform, which is owned by ContextLogic, Inc., a Delaware corporation (“ContextLogic”), that allows manufacturers, wholesalers and third-party merchants to advertise, distribute, offer for sale, sell and ship retail products originating from, primarily, China, amongst other locations, directly to consumers worldwide and specifically to consumers residing in the U.S., including New York (“Wish”), as well as those platforms and/or entities identified as a result of any expedited discovery order entered in the Lawsuit (hereinafter collectively referred to as the “Restrained Persons”), are permanently enjoined and restrained from:

- A. manufacturing, importing, exporting, advertising, marketing, promoting, distributing, displaying, offering for sale, selling and/or otherwise dealing in Counterfeit Products and/or Infringing Products or any other products bearing the Off-White Marks and/or marks that are confusingly similar to, identical to and constitute a counterfeiting and/or infringement of the Off-White Marks;
- B. directly or indirectly infringing in any manner any of Plaintiff’s trademarks, copyrights or other rights (whether now in existence or hereafter created) including, without limitation, the Off-White Marks;
- C. using any reproduction, counterfeit, copy or colorable imitation of Plaintiff’s trademarks, copyrights or other rights (whether now in existence or hereafter created)

- including, without limitation, the Off-White Marks to identify any goods or services not authorized by Plaintiff;
- D. using any of Plaintiff's trademarks, copyrights or other rights (whether now in existence or hereafter created) including, without limitation, the Off-White Marks, or any other marks or artwork that are confusingly similar to the Off-White Marks on or in connection with Defaulting Defendants' manufacturing, importing, exporting, advertising, marketing, promoting, distributing, displaying, offering for sale, selling and/or otherwise dealing in the Counterfeit Products and/or Infringing Products;
- E. using any false designation of origin or false description, or engaging in any action which is likely to cause confusion, cause mistake and/or to deceive members of the trade and/or the public as to the affiliation, connection or association of any product manufactured, imported, exported, advertised, marketed, promoted, distributed, displayed, offered for sale or sold by Defaulting Defendants with Plaintiff, and/or as to the origin, sponsorship or approval of any product manufactured, imported, exported, advertised, marketed, promoted, distributed, displayed, offered for sale or sold by Defaulting Defendants and Defaulting Defendants' commercial activities by Plaintiff;
- F. secreting, concealing, destroying, altering, selling off, transferring or otherwise disposing of and/or dealing with: (i) Counterfeit Products; (ii) any computer files, data, business records, documents or any other records or evidence relating to:
- i. any and all websites and/or accounts held by or associated with Defaulting Defendants, their respective officers, employees, agents, servants and all persons in active concert or participation with any of them ("User Accounts") and/or Defaulting Defendants' User Accounts

through which Defaulting Defendants, their respective officers, employees, agents, servants and all persons in active concert or participation with any of them manufacture, import, export, advertise, market, promote, distribute, offer for sale, sell and/or otherwise deal in products, including the Counterfeit Products, which are held by or associated with Defaulting Defendants, their respective officers, employees, agents, servants and all persons in active concert or participation with any of them (“Merchant Storefront(s)”);

j. Defaulting Defendants’ Assets (as defined *infra*), and

k. the manufacture, importation, exportation, advertising, marketing, promotion, distribution, display, offering for sale and/or sale of Counterfeit Products by Defaulting Defendants and by their respective officers, employees, agents, servants and all persons in active concert or participation with any of them;

G. secreting, concealing, transferring, disposing of, withdrawing, encumbering or paying any money, securities or other property or assets of Defaulting Defendants (whether said assets are located in the U.S. or abroad) (“Defaulting Defendants’ Assets”) from or to accounts associated with or utilized by any Defaulting Defendant or any Defaulting Defendants’ User Accounts or Merchant Storefronts (whether said account is located in the U.S. or abroad) (“Defaulting Defendants’ Financial Accounts”) until further ordered by this Court;

H. effecting assignments or transfers, forming new entities or associations, or creating and/or utilizing any other platform, User Accounts, Merchant Storefronts or any other

means of importation, exportation, advertising, marketing, promotion, distribution, display, offering for sale and/or sale of Counterfeit Products for the purposes of circumventing or otherwise avoiding the prohibitions set forth in this Default Judgment Order;

- I. providing services to Defaulting Defendants and Defaulting Defendants' User Accounts and Merchant Storefronts, including, without limitation, continued operation of Defaulting Defendants' User Accounts and Merchant Storefronts; and
- J. knowingly instructing, aiding or abetting any other person or business entity in engaging in any of the activities referred to in subparagraphs (II)(1)(A) through (I) *supra*.

2) IT IS FURTHER ORDERED, ADJUDGED AND DECREED that Defaulting Defendants must deliver up for destruction to Plaintiff any and all Counterfeit Products and any and all packaging, labels, tags, advertising and promotional materials and any other materials in the possession, custody or control of Defaulting Defendants that infringe any of Plaintiff's trademarks, copyrights or other rights including, without limitation, the Off-White Marks, or bear any marks that are confusingly similar to the Off-White Marks pursuant to 15 U.S.C. § 1118;

**IV. Post-Judgment Asset Transfer and Asset Freeze Order**

1) IT IS FURTHER ORDERED, ADJUDGED AND DECREED that in accordance with Rule 64 of the Federal Rules of Civil Procedure, 15 U.S.C. § 1116(a) and this Court's inherent equitable powers to issue remedies ancillary to its authority to provide final relief, and given the difficulties Plaintiff would have enforcing this Default Judgment Order, Defaulting Defendants' Assets from Defaulting Defendants' Financial Accounts that were and/or are

attached and frozen or restrained pursuant to the TRO and/or PI Order, or which are attached and frozen or restrained pursuant to any future order entered by the Court in this Action, (collectively, “Defaulting Defendants’ Frozen Assets” and “Defaulting Defendants’ Frozen Accounts,” respectively), are, to the extent that a given Defaulting Defendant’s Frozen Assets equal the Defaulting Defendants’ Individual Damages Award, hereby released and transferred to Plaintiff as full satisfaction of the Defaulting Defendants’ Individual Damages Award for that Defaulting Defendant, and those Defaulting Defendant’s Frozen Assets shall be transferred to Plaintiff through Plaintiff’s counsel forthwith, and upon receipt by Plaintiff’s counsel of such Defaulting Defendant’s Frozen Assets in full satisfaction of the Defaulting Defendants’ Individual Damages Award, the Financial Institution(s) holding that Defaulting Defendant’s Frozen Assets and Defaulting Defendants’ Frozen Accounts may unfreeze that Defaulting Defendant’s Frozen Assets and Defaulting Defendant’s Frozen Accounts. To the extent that a Defaulting Defendant’s Frozen Assets are less than the Defaulting Defendants’ Individual Damages Award, that Defaulting Defendant’s Frozen Assets are hereby released and transferred to Plaintiff as partial satisfaction of the Defaulting Defendants’ Individual Damages Award for that Defaulting Defendant and those Defaulting Defendant’s Frozen Assets shall be transferred to Plaintiff through Plaintiff’s counsel forthwith, and

- 2) IT IS FURTHER ORDERED, ADJUDGED AND DECREED that in accordance with Rule 64 of the Federal Rules of Civil Procedure and this Court’s inherent equitable powers to issue remedies ancillary to its authority to provide final relief, and given the difficulties Plaintiff would have enforcing this Default Judgment Order, the Court also hereby grants Plaintiff’s request for a post-judgment restraining order continuing the attachment of each Defaulting Defendant’s Frozen Assets until Plaintiff has recovered the full payment of the Defaulting

Defendants' Individual Damages Award owed to it by that Defaulting Defendant under this Default Judgment Order, or until further order of this Court; and

3) IT IS FURTHER ORDERED, ADJUDGED AND DECREED that in accordance with this Court's inherent equitable powers to issue remedies ancillary to its authority to provide final relief, and given the difficulties Plaintiff would have enforcing this Default Judgment Order, until Plaintiff has recovered the full payment of the Defaulting Defendants' Individual Damages Award owed to it by any Defaulting Defendant under this Default Judgment Order, in the event that Plaintiff discovers new and/or additional Defaulting Defendants' Assets (whether said assets are located in the U.S. or abroad) and/or Defaulting Defendants' Financial Accounts (whether said account is located in the U.S. or abroad) ("Defaulting Defendants' Additional Assets" and "Defaulting Defendants' Additional Financial Accounts," respectively), Plaintiff shall have the ongoing authority to serve this Default Judgment Order on any Financial Institutions controlling or otherwise holding such Defaulting Defendants' Additional Assets and/or Defaulting Defendants' Additional Financial Accounts ("Financial Institutions Holding Defaulting Defendants' Additional Assets and/or Financial Accounts");

A. Upon notice of this Default Judgment Order, Financial Institutions Holding Defaulting Defendants' Additional Assets and/or Financial Accounts shall immediately locate Defaulting Defendants' Additional Financial Accounts, attach and restrain such Defaulting Defendants' Additional Assets in Defaulting Defendants' Additional Financial Accounts from being secreted, concealed, transferred or disposed of or withdrawn; and

B. After twenty (20) business days following the service of this Default Judgment Order on Financial Institutions Holding Defaulting Defendants' Additional Assets and/or

Financial Accounts, Financial Institutions Holding Defaulting Defendants' Additional Assets and/or Financial Accounts shall transfer all Defaulting Defendants' Additional Assets to Plaintiff as partial or full satisfaction of the Defaulting Defendants' Individual Damages Award, unless Defaulting Defendant has filed with this Court and served upon Plaintiff's counsel a request that such Defaulting Defendants' Additional Assets be exempted from this Default Judgment Order.

**V. Miscellaneous Relief**

- 1) Defaulting Defendants may, upon proper showing and two (2) business days written notice to the Court and Plaintiff's counsel, appear and move for dissolution or modification of the provisions of this Default Judgment Order concerning the restriction or restraint of Defaulting Defendants' Frozen Assets, Defaulting Defendants' Additional Assets and/or Defaulting Defendants' Additional Financial Accounts;
- 2) Any failure by Defaulting Defendants to comply with the terms of this Default Judgment Order shall be deemed contempt of Court, subjecting Defaulting Defendants to contempt remedies to be determined by the Court, including fines and seizure of property; and
- 3) This Court shall retain jurisdiction over this matter and the parties in order to construe and enforce this Default Judgment Order.

**SO ORDERED.**

SIGNED this 16 day of November, 2018  
New York, New York

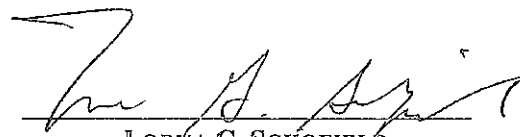
  
LORNA G. SCHOFIELD  
UNITED STATES DISTRICT JUDGE



# **EXHIBIT 6**

2017 WL 836228

Only the Westlaw citation is currently available.  
United States District Court, N.D. Illinois, Eastern  
Division.

LUXOTTICA GROUP S.P.A. and Oakley, Inc.,  
Plaintiffs,

v.

LI CHEN, et al., Defendants.

No. 16 C 6850

Signed 03/02/2017

#### Attorneys and Law Firms

Justin R. Gaudio, Jessica Lea Bloodgood, Kevin W. Guynn, Amy Crout Ziegler, Greer Burns & Crain Ltd., Chicago, IL, for Plaintiffs.

Jeffrey Stewart Firestone, New Paltz, NY, for Defendants.

### OPINION AND ORDER

SARA L. ELLIS, United States District Judge

\*1 Plaintiffs Luxottica Group S.p.A. (“Luxottica”) and Oakley, Inc. (“Oakley”) seek summary judgment and monetary and injunctive relief against the Defendant operating the internet stores *clio4u*, *exrell*, *gagaoutleteb*, and *onlyservicenquality*, through which Plaintiffs allege Defendant advertised and offered for sale hats that used **counterfeit** reproductions of Plaintiffs’ federally registered Oakley **trademarks**. Plaintiffs’ claims arise under the Lanham Act for **trademark** infringement and **counterfeiting**, 15 U.S.C. § 1114, and false designation of origin, 15 U.S.C. § 1125(a), and under the Illinois Uniform Deceptive Trade Practices Act (“UDTPA”), 815 Ill. Comp. Stat. 510/1 *et seq.* The parties agree on liability, leaving the Court to decide only the proper remedies. Having considered the relevant factors and finding Defendant’s infringement willful, the Court awards Plaintiffs \$100,000 in statutory damages and reasonable attorneys’ fees and costs. The Court also enters a permanent injunction prohibiting Defendant from

violating Plaintiffs’ rights in the Oakley **trademarks**.

### **BACKGROUND<sup>2</sup>**

Oakley manufactures eyewear, headwear, footwear, outerwear, jackets, and apparel. Its products are known by its distinctive marks, which have been trademarked and used exclusively and continuously by Plaintiffs since as early as 1975. Oakley holds numerous valid and incontestable federal **trademarks**, including under numbers 1,522,692, 1,980,039, 1,984,501, 2,293,046, 2,300,245, and 3,331,124. Defendant operates several online marketplace accounts, including the eBay internet stores *clio4u*, *exrell*, *gagaoutleteb*, and *onlyservicenquality*, and uses multiple PayPal accounts to sell hats with **counterfeit** Oakley **trademarks**, without Oakley’s authorization, for between \$2.75 and \$4.95. These hats each displayed four of Oakley’s **trademarks**. *See* Doc. 64 at 9. Defendant described the hats in listings as, for example, “Men Women Adjustable Golf Hip-hop Sports Summer Baseball Caps Sun Hat Unisex.” Doc. 65 ¶ 2, Defendant advertised and sold these products to customers in Illinois and elsewhere in the United States.

Two of Defendant’s employees, Chen Xia and Li Juan, submitted affidavits indicating that Defendant sold only eleven hats with the Oakley **trademarks** for a total of approximately \$62. According to these employees, they bought these products from a Chinese wholesaler and could not determine from the wholesaler’s website or information about the products that the hats infringed the Oakley **trademarks** or were otherwise **counterfeit** goods. They maintain that Defendant has procedures in place to avoid infringement problems, but that being “offshore Chinese resident buyers,” they had “never heard of Oakley nor of the subject logo.” Doc. 70-1 at 2; Doc. 70-2 at 2. As a result, they claim not to have known that the written logo on the hat was trademarked and that any infringement was unintentional.

### **LEGAL STANDARD**

\*2 Summary judgment obviates the need for a trial where there is no genuine issue as to any material fact and the moving party is entitled to judgment as a matter of law.

Fed. R. Civ. P. 56. To determine whether a genuine issue of fact exists, the Court must pierce the pleadings and assess the proof as presented in depositions, answers to interrogatories, admissions, and affidavits that are part of the record. Fed. R. Civ. P. 56 & advisory committee's notes. The party seeking summary judgment bears the initial burden of proving that no genuine issue of material fact exists. *Celotex Corp. v. Catrett*, 477 U.S. 317, 323, 106 S. Ct. 2548, 91 L.Ed. 2d 265 (1986). In response, the non-moving party cannot rest on mere pleadings alone but must use the evidentiary tools listed above to identify specific material facts that demonstrate a genuine issue for trial. *Id.* at 324; *Insolia v. Philip Morris Inc.*, 216 F.3d 596, 598 (7th Cir. 2000). Although a bare contention that an issue of fact exists is insufficient to create a factual dispute, *Bellaver v. Quanex Corp.*, 200 F.3d 485, 492 (7th Cir. 2000), the Court must construe all facts in a light most favorable to the non-moving party and draw all reasonable inferences in that party's favor. *Anderson v. Liberty Lobby, Inc.*, 477 U.S. 242, 255, 106 S. Ct. 2505, 91 L.Ed. 2d 202 (1986).

## ANALYSIS

### I. Liability

Plaintiffs move for summary judgment on their claims of **trademark** infringement and **counterfeiting** under 15 U.S.C. § 1114 (Count I), false designation of origin under 15 U.S.C. § 1125(a) (Count II), and violation of the UDTPA, 815 Ill. Comp. Stat. 510/1 *et seq.* (Count IV). The UDTPA violation is based on the same conduct as the federal Lanham Act claims. Defendant does not dispute liability, instead only challenging the amount of damages it owes Plaintiffs. Therefore, the Court grants summary judgment for Plaintiffs with respect to their **trademark** infringement and **counterfeiting**, false designation of origin, and UDTPA claims and proceeds to determine the relief to which they are entitled.

### II. Statutory Damages

Plaintiffs request that the Court award them statutory damages of at least \$200,000 for Defendant's willful **counterfeiting** of the Oakley **trademarks**. Section 1117(c)(1) provides that, in place of an award of actual

damages and profits, a plaintiff may elect an award of statutory damages between \$1,000 and \$200,000 "per **counterfeit** mark per type of goods or services sold, offered for sale, or distributed." 15 U.S.C. § 1117(c)(1). This award may be increased, up to \$2,000,000, if the Court "finds that the use of the **counterfeit** mark was willful." *Id.* § 1117(c)(2). "Willful infringement may be attributed to the defendant's actions where he had knowledge that his conduct constituted infringement or where he showed a reckless disregard for the owner's rights." *Bulgari, S.P.A. v. Zou Xiaohong*, No. 15-cv-05148, 2015 WL 6083202, at \*2 (N.D. Ill. Oct. 15, 2015) (citation omitted). A defendant's knowledge can be inferred from his conduct. *Id.* In assessing the amount to award, the Court has "wide discretion" but should consider such factors as "the difficulty or impossibility of proving actual damages, the circumstances of the infringement, and the efficacy of the damages as a deterrent to future [**trademark**] infringement." *Chi-Boy Music v. Charlie Club, Inc.*, 930 F.2d 1224, 1230 (7th Cir. 1991) (quoting *F.E.L. Publ'ns v. Catholic Bishop of Chicago*, 754 F.2d 216, 219 (7th Cir. 1985)).<sup>3</sup> In the case of willful infringement, "the statutory damages award may be designed to penalize the infringer and to deter future violations." *Id.* at 1230 (7th Cir. 1991).

Defendant asks the Court to award minimal damages, arguing that it did not infringe intentionally and instead was unaware that the Oakley hats it sold infringed the Oakley **trademarks**. Defendant maintains that it follows procedures to comply with intellectual property laws, requiring purchasing employees to compare logos or words appearing in its online listings with **trademark** databases. It claims to have purchased the hats from a Chinese wholesaler that fooled it into thinking the hats were genuine. Defendant claims that the pictures provided by the wholesaler did not allow Defendant to recognize the Oakley **trademarks**. These unsupported statements, when compared to the listings for the hats, where the Oakley name is clearly recognizable in the photographs of the hats advertised for sale, are unpersuasive. The Oakley **trademarks** are relatively well known, with Oakley having invested significantly in ensuring widespread recognition of its brand, and could not have been so foreign or obscure to escape attention, particularly that of merchandisers allegedly trained to detect **counterfeit** products. As such, Defendant's employees' statements that they could not make out the stylized writing on the photographs of the hat to at least recognize that it comprised a logo and thus raised a potential **trademark** problem borders on the unbelievable. *See Zou Xiaohong*, 2015 WL 6083202, at \*2 (finding unpersuasive defendant's unsubstantiated statements that he was not familiar with European luxury products or brand names).

Defendant also points out that the descriptions of the products did not use the word Oakley to suggest its innocence, but this absence could just as easily be evidence of willful action taken to avoid detection. See *River Light*, 2016 WL 4429758, at \*3 (noting that wording of product description was “consistent with the actions of an intentional infringer, who would try to maximize sales of infringing products while minimizing the risk of the infringement being discovered”); *Zou Xiaohong*, 2015 WL 6083202, at \*2 (omission of BVLGARI mark in product description permitted inference of willful infringement). At the least, the Court finds that Defendant acted with willful blindness to the **counterfeit** nature of the hats it advertised for sale. See *River Light*, 2016 WL 4429758, at \*3 (finding that defendant’s explanation that it did not recognize plaintiff’s **trademark** suggested at the least willful blindness). Such willful blindness is enough to allow for an increased damages award. See *Louis Vuitton S.A. v. Lee*, 875 F.2d 584, 590 (7th Cir. 1989) (“Willful blindness is knowledge enough.”).

\*3 Defendant also argues that Plaintiffs’ requested damages award of \$200,000 is excessive, particularly because Defendant only sold eleven hats with infringing Oakley **trademarks** for a total of approximately \$62 and claims not to be a large-scale **counterfeiter**.<sup>4</sup> The actual damages Plaintiffs suffered do not ultimately matter, however, as Plaintiffs have elected to pursue statutory damages under § 1117(c). But the Court does acknowledge that Plaintiffs have not introduced evidence that Defendant operates a large-scale **counterfeiting** operation or that they suffered significantly from these particular instances of infringement.<sup>5</sup> At the same time, however, Defendant had the potential to reach a wide audience with its **counterfeit** goods because it advertised them on the internet, allowing for distribution far greater than if it sold the hats in a brick-and-mortar store. Compare *Luxottica USA LLC v. The Partnerships & Unincorporated Ass’ns Identified on Schedule “A”*, No. 14 C 9061, 2015 WL 3818622, at \*2–3 (N.D. Ill. June 18, 2015) (collecting awards from cases where **counterfeiting** took place online that found “substantial damages awards appropriate,” ranging between \$50,000 and \$750,000 per mark), with *Coach, Inc. v. Treasure Box, Inc.*, No. 3:11CV468-PBS, 2014 WL 888902, at \*4 (N.D. Ind. Mar. 6, 2014) (awarding \$3,000 per mark against a brick-and-mortar infringer that was no longer in operation, noting “the small scale of [its] brief operation”); *Coach, Inc. v. Becka*, No. 5:11-CV-371(MTT), 2012 WL 5398830, at \*6–7 (M.D. Ga. Nov. 2, 2012) (awarding \$2,000 per mark, noting that the defendant “was operating out of a single small retail location, and [she] did not sell or advertise the counterfeit

items on the Internet”).

The Court also takes into account Plaintiffs’ significant efforts to protect and promote the Oakley brand. See *Lorillard Tobacco Co. v. S&M Cent. Serv. Corp.*, No. 03 C 4986, 2004 WL 2534378, at \*6 (N.D. Ill. Nov. 8, 2004) (“[T]he significant value of Lorillard’s brand and the efforts taken to protect, promote, and enhance that brand should be considered by the court in the determination of the appropriate dollar figure of the award.”). Plaintiffs began using the Oakley **trademarks** as early as 1975, have engaged in significant marketing and branding campaigns, and have sought to protect the brand by filing suits, such as this one, against **counterfeiters**. “The proliferation of lower-quality, **counterfeit** goods damages a brand’s value and goodwill, and a significant award is required to deter defendant and others from engaging in similar conduct.” *River Light*, 2016 WL 4429758, at \*4. The Court thus finds it appropriate to impose a higher award to deter future infringement by Defendant and others because “[a] **counterfeiter** must fear more than just having to turn over his ill-gotten gains to the rightful owners.” *Lorillard Tobacco Co.*, 2004 WL 2534378, at \*6. In mitigation, the Court acknowledges that Defendant does not appear to be selling any additional Oakley **counterfeit** products and retained an attorney to defend it in this case instead of failing to appear.

Considering the factors discussed above, the Court finds it appropriate to award Plaintiffs \$100,000 in statutory damages.

### III. Permanent Injunction

Plaintiffs also ask that the Court permanently enjoin Defendant from advertising and selling **counterfeit** Oakley products or otherwise violating their rights in the Oakley **trademarks**. Defendant does not address this request in its response, appearing to concede the issue. See *Bonte v. U.S. Bank, N.A.*, 624 F.3d 461, 466 (7th Cir. 2010) (“Failure to respond to an argument ... results in waiver.”). The Court finds Plaintiffs’ request appropriate: Defendant infringed the Oakley **trademarks**; the harm to the Oakley brand cannot be fully compensated by the statutory damages award, see, e.g., *Re/Max N. Cent., Inc. v. Cook*, 272 F.3d 424, 432 (7th Cir. 2001) (“[D]amage to a **trademark** holder’s goodwill can constitute irreparable injury for which the **trademark** owner has no adequate legal remedy.”); the requested injunction merely prohibits Defendant from violating the law; and the public interest favors Plaintiffs because “enforcement of the **trademark** laws prevents consumer confusion,” *Eli Lilly & Co. v.*

*Natural Answers, Inc.*, 233 F.3d 456, 469 (7th Cir. 2000). Thus, the Court grants Plaintiffs' request for a permanent injunction.

## CONCLUSION

For the foregoing reasons, the Court grants Plaintiffs' motion for summary judgment [63]. The Court enters judgment for Plaintiffs on Counts I, II, and IV. The Court enters a permanent injunction prohibiting Defendant from violating Plaintiffs' rights in the Oakley **trademarks**. The Court awards Plaintiffs \$100,000 in statutory damages and their attorneys' fees and costs. Plaintiffs shall submit a motion for attorneys' fees and a bill of costs by April 7, 2017, with Defendant's response due by April 21, 2017.

### IV. Attorneys' Fees and Costs

\*4 Finally, Plaintiffs ask that the Court award them their attorneys' fees and costs. Plaintiffs may recover attorneys' fees under § 1117(a) and (b) for, among other things, the willful or intentional use of the **counterfeit** mark. 15 U.S.C. § 1117(a)-(b). These provisions apply even where the plaintiff has elected to receive statutory instead of actual damages. See *Louis Vuitton Malletier S.A. v. LY USA, Inc.*, 676 F.3d 83, 111 (2d Cir. 2012). Because the Court has found that Defendant acted willfully, the Court awards Plaintiffs their reasonable attorneys' fees. Additionally, as the prevailing party, Plaintiffs are entitled to costs under Federal Rule of Civil Procedure 54(d)(1).

### All Citations

Not Reported in Fed. Supp., 2017 WL 836228

### Footnotes

- 1 Oakley is an indirect, wholly-owned subsidiary of Luxottica. The Court collectively refers to Oakley and Luxottica as Plaintiffs.
- 2 The facts in this section are derived from the Joint Statement of Undisputed Material Facts and the additional declarations submitted by the parties. All facts are taken in the light most favorable to Defendant, the non-movant.
- 3 Although *Chi-Boy Music* addressed the statutory damages scheme for copyright infringement, its analysis has been found equally applicable to determining statutory damages for trademark infringement. See *River Light V, L.P. v. Zhangyali*, No. 15 CV 5918, 2016 WL 4429758, at \*3 (N.D. Ill. Aug. 22, 2016).
- 4 Although Defendant consistently refers to PayPal or other records that would establish actual damages or show how much Defendant actually profited from the infringing sales, Defendant does not supply these records, instead only providing identical affidavits from two employees stating the amount of sales without supporting records. Plaintiffs did submit an email from Defendant to counsel in which Defendant laid out the amounts for which each hat sold and the profit made on each transaction, but again, these numbers are not supported by any underlying documents.
- 5 It does appear that Defendant operates at least one additional eBay store, whitesibirien, named as a defendant in a separate case brought by Plaintiffs in this district, *Luxottica Grp. S.p.A. v. Li Ning*, No. 16 C 7455 (N.D. Ill.). To Plaintiffs, this suggests that Defendant has concealed the extent of its business operations, an additional reason for awarding higher statutory damages.